

## UltraSIL Polymer-Housed VariSTAR Surge Arresters: Normal-Duty (5 kA), Heavy-Duty (10 kA), and Heavy-Duty Riser Pole (10 kA)

Electrical Apparatus  
235-35

### GENERAL

Cooper Power Systems has set the standard for design, manufacturing and delivery of polymeric distribution-class arresters with UltraSIL polymer-housed arrester family. UltraSIL polymer-housed surge arrester incorporates the industry recognized superior polymer housing material – silicone rubber.

Available in Normal Duty, Heavy-Duty and Heavy-Duty Riser Pole classifications, UltraSIL polymer-housed VariSTAR distribution-class surge arresters provide superior overvoltage protection for any electric distribution system.

### CONSTRUCTION

The patented construction of UltraSIL polymer-housed arresters begins with Metal Oxide Varistor's (MOVs) manufactured at our Olean, NY facility. Manufacturing our own MOVs allows for strict quality control over all aspects of disk production. Every MOV must pass a series of physical and electrical tests designed to ensure that only disks meeting strict quality standards are used in UltraSIL arresters. The Cooper Power Systems MOV disk design has proven its reliability and protective ability through many years of field service.

The MOV disks are combined with aluminum end electrodes and are encapsulated in a high-strength composite wrap insulating material on our fully automated assembly line using strict quality control processes that eliminate manufacturing variances. The composite collar is cured to the MOV disk stack to form a solid insulation MOV disk module system that is inserted and bonded to the industry leading track resistant UltraSIL silicone rubber housing.

This exclusive Cooper Power Systems patented manufacturing process forms a secondary moisture seal under the primary silicone rubber housing seal, which makes the arrester impervious to moisture and capable of withstanding extreme electrical, environmental

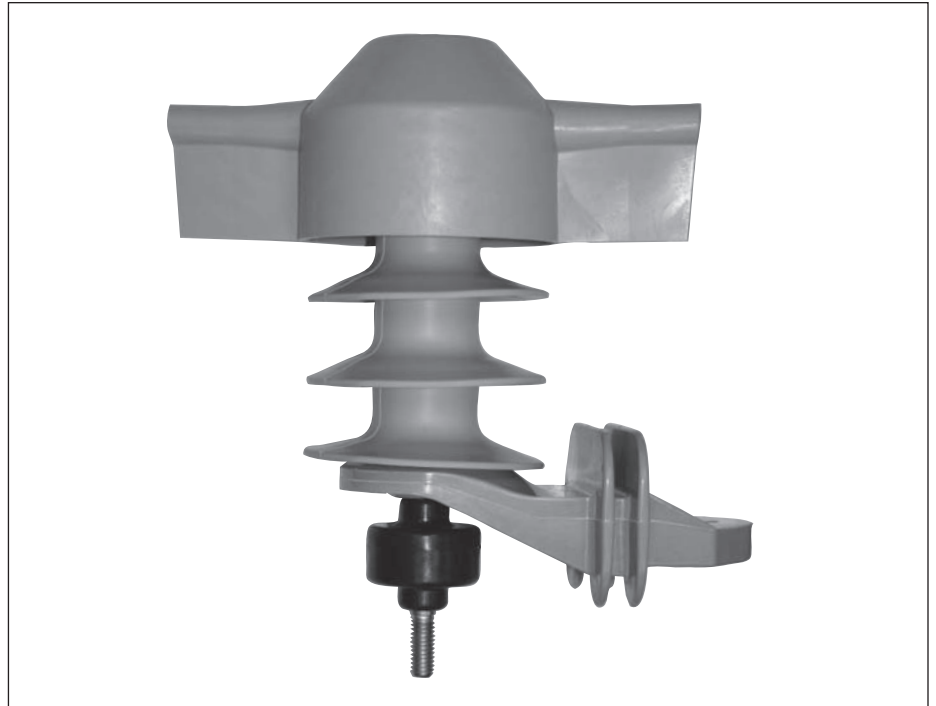

**Figure 1.**  
10 kV UltraSIL polymer-housed VariSTAR distribution-class surge arrester.

and cantilever load conditions. The composite wrapped UltraSIL polymer-housed arrester design represents a quantum leap in polymer arrester technology.

Following assembly, each arrester is subjected to a battery of electrical tests to assure the highest quality and in-service field performance.

### FEATURES

UltraSIL silicone rubber polymer-housing has undergone a wide range of design tests to determine the optimum shed configuration. In addition, long term environmental testing has verified the lifetime superiority of silicone rubber when compared to other polymeric insulating materials.

Independent laboratory tests have verified the superiority of silicone rubber in terms of non-wetting surfaces, resistance to UV degradation and surface tracking, performance in contaminated environments, chemical inertness, temperature stability and other

important insulating properties. UltraSIL silicone rubber polymer-housing will not support biological growth (algae and mildew), is non-flammable and will not support combustion.

An optional insulated mounting base is available to allow connecting to a wide variety of brackets. The insulated base, made of glass filled polyester, has been designed to provide needed mechanical strength for installation and severe loading conditions.

A ground lead isolator is also available. The isolator removes the ground terminal from the arrester in the unlikely event of arrester failure, thus preventing a permanent system fault. An isolator that has operated gives visual indication of internal damage to the arrester and the need for arrester replacement.

The optional universal wildlife protector has two self-adjusting "valve" style openings which vary from 0 to 0.75" in diameter, thus allowing for a large variety of conductor/insulation sizes

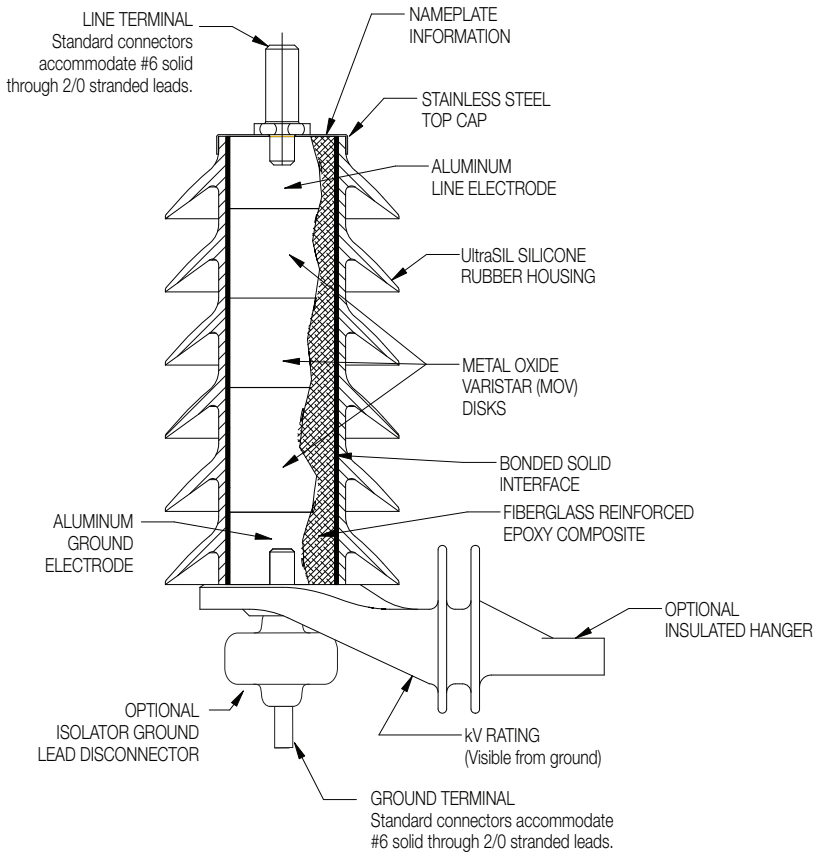

**Figure 2.**  
Cutaway illustration of VariSTAR distribution-class arrester.

while providing optimum wildlife protection. (See page 10, Figure 8 for a dimensional diagram.)

Customers looking to improve system reliability may specify the CooperGuard to minimize wildlife related outages. CooperGuard is easily retrofitted to existing arresters installations and provides increased electrical insulation for the high-voltage terminal of the arrester. The flexible design of CooperGuard allows insertion of the lead wire through the bottom of the integral molded flanges. The access holes molded above the flanges will allow conductor sizes ranging from 0 to 0.50" in diameter (OD). CooperGuard geometry allows water to shed away from the surface area of the animal guard while minimizing ice build up and maintaining flexibility through extreme operating temperatures. (Refer to page 10, Figure 9 for a dimensional diagram.)

## OPERATION

The operation of VariSTAR arresters is typical of gapless metal oxide arresters. During steady state conditions, line-to-ground voltage is applied continuously across the arrester terminals. When surges occur, VariSTAR arresters immediately limits the overvoltage to the required protective level by conducting the surge current to ground. Upon passage of the surge, the arrester returns to its initial state, conducting minimal leakage current.

The protective characteristics of VariSTAR arresters provide excellent overvoltage protection for distribution system equipment. (See page 6 for protective characteristics.)

## DESIGN TESTING

The housing material, internals and hardware work together as a system and must stand up to years of exposure to environmental extremes. To assure a superior level of performance, both the components

and the assembled arrester units have been subjected to a program of testing that accurately simulates years of exposure to actual field conditions. Testing includes:

- IEEE Std C62.11-2005™ standard Testing – Full certification to performance requirements by an independent laboratory. A certified test report is available under Bulletin Number 95062.

Additional design verification testing of VariSTAR arrester include:

- UV testing
- Full dielectric testing
- Wet Arc Tracking Resistance
- Thermal Shock test
- Multi-Stress Environmental test cycling
- Tracking Wheel test
- Coefficients of expansion for materials compatibility
- Cantilever test
- Terminal and Isolator Torque test
- Hanger Mechanical Shock test

This is only a partial listing of design tests performed on the VariSTAR distribution-class arrester. For detailed test reports and results please contact your Cooper Power Systems sales representative.

## PRODUCTION TESTS

A complete production test program ensures a quality product. Each metal oxide varistor receives a series of electrical tests. Quality is demonstrated by a series of destructive tests performed on every batch of varistors. Listed are the tests performed on the varistors:

- 100% Physical Inspection
- 100% Discharge Voltage test
- 100%  $V_{1mA/cm^2}$
- 100% Leakage Current at 80% of  $V_{1mA/cm^2}$  Voltage (Watts Loss)
- Batch High-current, Short-duration test
- Batch Thermal Stability test
- Batch Aging test

Each fully assembled VariSTAR arrester must pass the following production tests:

- 100% Physical Inspection
- 100% Leakage Current test
- 100% Partial Discharge Inception Voltage test

## GENERAL APPLICATION RECOMMENDATIONS

The rating of an arrester is the maximum power frequency line-to-ground voltage at which the arrester is designed to pass an operating duty-cycle test. Table 1 provides a general application guide for the selection of the proper arrester rating for a given system voltage and system grounding configuration as outlined in the IEEE Std C62.22™ standard application guide.

Under fault conditions and other system anomalies, higher voltages can be experienced by the arrester. To ensure that the arrester ratings will not be exceeded, Cooper Power Systems application engineers are available to make recommendations. The following information is normally required:

1. System maximum operating voltage.
2. System grounding conditions.
  - A. For four-wire circuits, grounding conditions depend upon whether the system is multi-grounded, whether it has a neutral impedance and whether common primary and secondary neutrals are used.
  - B. For three-wire circuits, grounding conditions depend upon whether the system is solidly grounded at the source, grounded through neutral impedance at the source transformers or ungrounded.

Consult your Cooper representative to have your individual system application needs studied.

## PERFORMANCE TEST CHARACTERISTICS

VariSTAR distribution-class arresters withstand the following design tests as described by IEEE Std C62.11-2005™ standard:

- **Duty Cycle:**  
Normal-Duty: 22 current surges of 5 kA crest, 8/20  $\mu$ s wave-shape.  
Heavy-Duty: 20 current surges of 10 kA crest, 8/20  $\mu$ s waveshape followed by 2 current surges of 40 kA crest, 8/20  $\mu$ s waveshape.
- **High-current, Short-duration Discharge:**  
Normal-Duty: 2 current surges of 65 kA crest, 4/10  $\mu$ s waveshape.

TABLE 1  
Commonly Applied Voltage Ratings of VariSTAR Arresters

System Voltage (kV rms)		Recommended Arrester Rating per IEEE Std C62.22™ standard (kV rms)		
Nominal	Maximum	Four-Wire Wye Multi-Grounded Neutral	Three-Wire Wye Solidly Grounded Neutral	Delta and Ungrounded Wye
2.4	2.54	—	—	3
4.16Y/2.4	4.4Y/2.54	3	6	6
4.16	4.4	—	—	6
4.8	5.08	—	—	6
6.9	7.26	—	—	9
8.32Y/4.8	8.8Y/5.08	6	9	—
12.0Y/6.93	12.7Y/7.33	9	12	—
12.47Y/7.2	13.2Y/7.62	9	15	—
13.2Y/7.62	13.97Y/8.07	10	15	—
13.8Y/7.97	14.52Y/8.38	10	15	—
13.8	14.52	—	—	18
20.78Y/12.0	22Y/12.7	15	21	—
22.86Y/13.2	24.2Y/13.87	18	24	—
23	24.34	—	—	30
24.94Y/14.4	26.4Y/15.24	18	27	—
27.6Y/15.93	29.3Y/16.89	21	30	—
34.5Y/19.92	36.5Y/21.08	27	36	—
46Y/26.6	48.3Y/28	36	—	—

Heavy-Duty: 2 current surges of 100 kA crest, 4/10  $\mu$ s wave-shape.

- **Low-Current, Long-Duration Discharge:**

Normal-Duty: 20 current surges of 75 A crest 2000  $\mu$ s duration rectangular wave.

Heavy-Duty: 20 current surges of 250 A crest 2000  $\mu$ s duration rectangular wave.

Following each of these tests, the arresters remain thermally stable as verified by:

- Continually decreasing power values during a thirty minute power monitoring period.
- No evidence of physical or electrical deterioration.
- The 5 kA (normal-duty) or 10 kA (heavy-duty) discharge voltages measured after each test changed less than 10% from the initial values.

In addition, full IEEE Std C62.11-2005™ standard certification has been completed and verified.

## FAULT CURRENT WITHSTAND TESTS

Fault current withstand tests demonstrate the ability to withstand fault currents for specific durations without expelling any internal components. All VariSTAR arrester designs have been tested in accordance with the requirements listed in IEEE Std C62.11-2005™ standard, and are non-fragmenting to the levels shown in Table 2.

TABLE 2  
Fault Current Withstand Tests

Fault Current Amplitude (kA rms)	Fault Current Duration (cycles)
0.6	60
20	12

## DIMENSIONS AND CLEARANCES

Outline drawings for several common design options are shown in Figures 3-6. Dimensions for these designs are listed in Table 3.

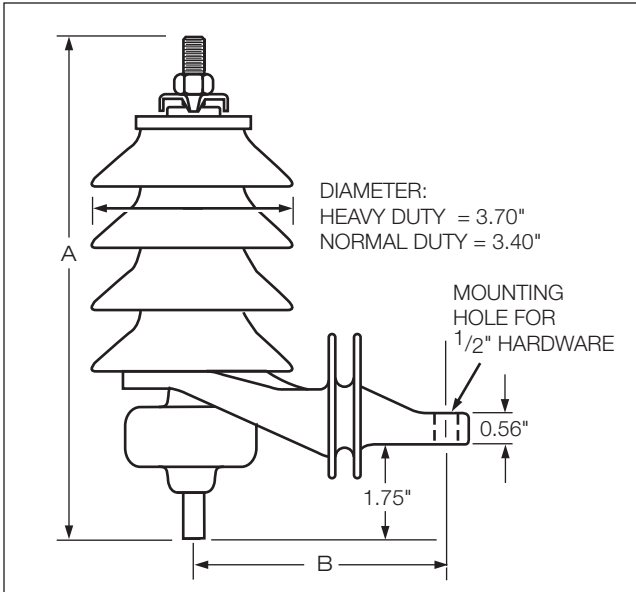

Figure 3. VariSTAR arrester with isolator and insulated hanger.

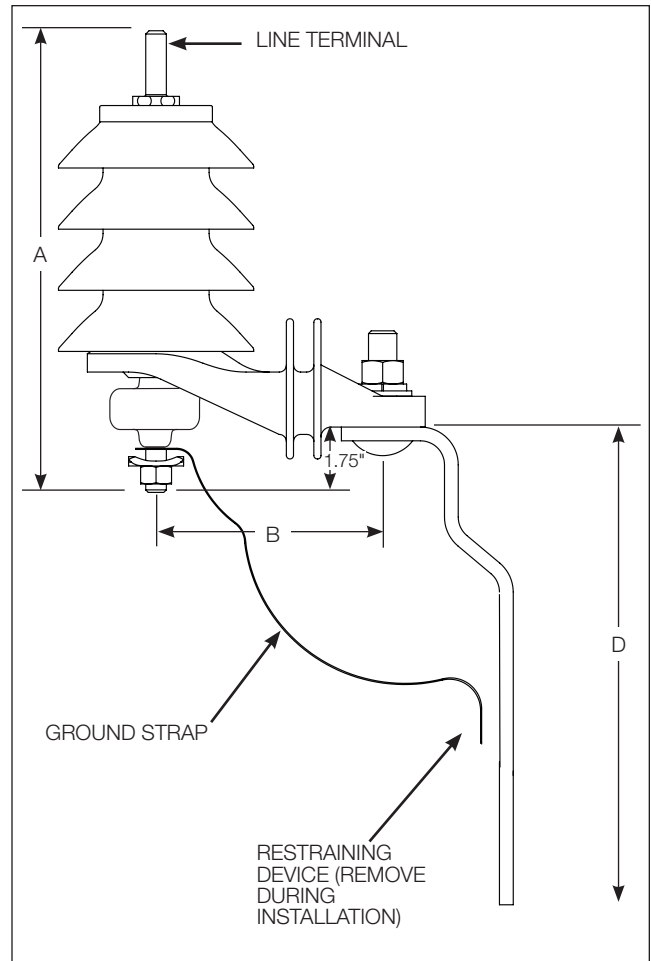

Figure 5. VariSTAR arrester with isolator, insulated hanger and transformer mounting bracket.

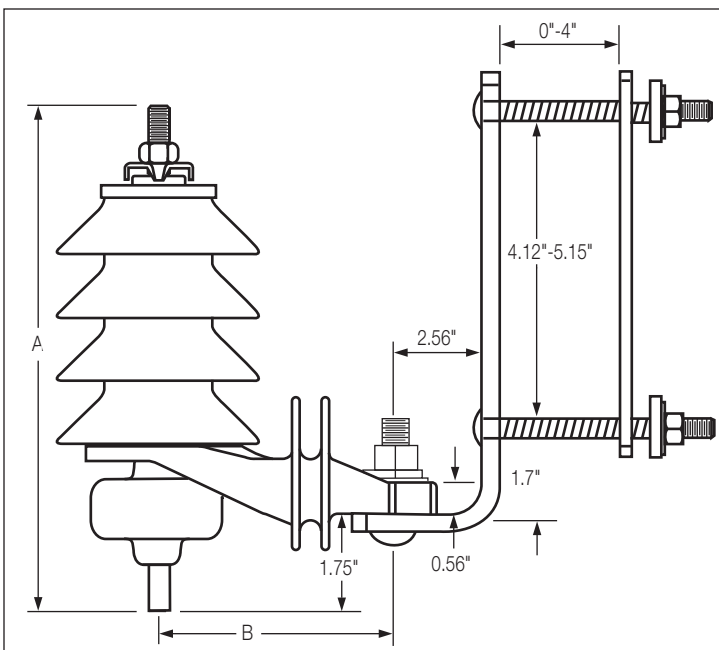

Figure 4. VariSTAR arrester with isolator, insulated hanger and NEMA cross-arm bracket.

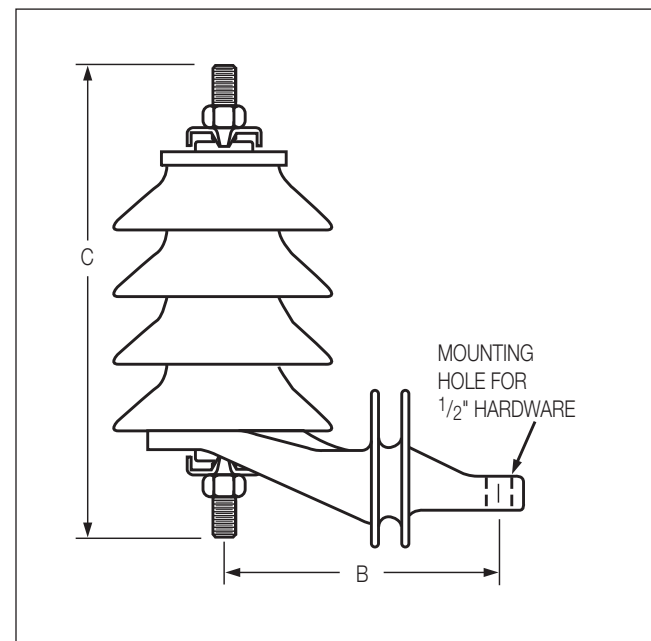

Figure 6. VariSTAR arrester with insulated hanger without isolator.

**TABLE 3**  
Dimensional Data – VariSTAR Arresters

Arrester Rating (kV rms)	Standard Housing Code (Digits 6 & 7)	Dimensions Figures 3-6, page 4 (Inches)				Minimum Recommended Clearances* (in.)			
						Heavy-Duty		Normal-Duty	
		A+	B	C+	D	Phase-to-Ground	Phase-to-Phase	Phase-to-Ground	Phase-to-Phase
3	3	6.9	4.1	5.5	8.7	3	4.25	2.75	3.75
6	4	7.9	4.1	6.5	8.7	4	5.5	3.75	5
9	5	9.0	4.1	7.6	8.7	5.25	7	5	6.5
10	5	9.0	4.1	7.6	8.7	5.25	7	5	6.5
12	6	10.0	5	8.6	8.7	6	7.75	5.75	7.25
15	7	11.1	5	9.7	8.7	6.75	8.75	6.5	8.25
18	8	12.2	5	10.8	8.7	9.25	11.25	9	10.75
21	9	13.2	5	11.8	8.7	9.25	11.25	9	10.75
24	10	14.3	5	12.9	8.7	10.75	13.25	10.5	12.75
27	11	15.3	5	13.9	14.3	10.75	13.25	10.5	12.75
30	12	16.4	5	15	14.3	10.75	13.25	10.5	12.75
33	13	17.5	5	16.1	14.3	12.75	16.25	12.5	15.75
36	14	18.5	5	17.1	14.3	12.75	16.25	12.5	15.75

\* All clearances are measured from center line of arrester per IEEE Std C62.22™ standard.  
+ With optional Wildlife Protector add 0.2 inches.

### INSULATION CHARACTERISTICS

The insulation characteristics of VariSTAR arrester family are shown in Table 4.

**TABLE 4**  
Housing Insulation Withstand Voltages of VariSTAR Arresters

Arrester Housing Code Digits (6 & 7)	Creep Distance (in.)	Strike (in.)	4.1" Mounting Configuration			5.0" Mounting Configuration			4.1" Mounting Configuration			5.0" Mounting Configuration			5.0" Mounting Configuration		
			1.2/50 $\mu$ s Impulse (kV crest)	1 Min. Dry (kV rms)	10 sec. Wet (kV rms)	1.2/50 $\mu$ s Impulse (kV crest)	1 Min. Dry (kV rms)	10 sec. Wet (kV rms)	1.2/50 $\mu$ s Impulse (kV crest)	1 Min. Dry (kV rms)	10 sec. Wet (kV rms)	1.2/50 $\mu$ s Impulse (kV crest)	1 Min. Dry (kV rms)	10 sec. Wet (kV rms)	1.2/50 $\mu$ s Impulse (kV crest)	1 Min. Dry (kV rms)	10 sec. Wet (kV rms)
3	7.2	3.1	78	47	24	92	50	37	70	44	24	85	53	30	70	42	24
4	10.1	4.2	91	56	36	105	55	39	79	52	34	99	56	39	82	51	33
5	13	5.2	104	64	45	117	63	52	89	55	44	109	60	52	90	62	46
6	15.9	6.3	117	78	57	126	86	59	93	61	58	119	80	59	97	72	56
7	18.8	7.3	129	87	68	137	96	71	98	62	59	122	81	63	107	81	69
8	21.7	8.4	140	96	79	148	106	83	104	65	61	126	82	67	118	89	81
9	24.6	9.4	152	105	89	159	116	94	110	68	63	130	83	72	129	98	93
10	27.5	10.5	164	114	100	171	126	105	117	72	67	136	86	78	140	106	105
11	30.4	11.5	176	123	110	183	135	116	125	77	71	142	90	83	152	114	116
12	33.3	12.6	189	131	120	195	144	127	133	82	75	149	94	89	164	122	126
13	36.2	13.6	201	139	130	207	153	137	142	88	81	158	99	96	177	130	136
14	39.1	14.7	215	148	140	220	161	147	152	94	87	167	105	102	190	138	145
15	42	15.8	228	155	150	233	170	157	162	101	93	177	112	109	204	146	153
16	44.9	16.8	242	183	158	246	178	167	173	109	101	187	120	117	218	154	162
17	47.8	17.8	255	171	169	259	185	176	185	117	109	199	128	125	233	161	169

**PROTECTIVE CHARACTERISTICS**

VariSTAR distribution-class arresters provide excellent overvoltage protection for electrical equipment

throughout distribution systems. The protective characteristics of the VariSTAR arrester family are shown in Tables 5, 6, and 7.

**TABLE 5**  
Protective Characteristics – VariSTAR Normal-Duty (UNS) Arrester

Arrester Rating (kV rms)	MCOV (kV rms)	Front-of-wave Protective Level* (kV crest)	Maximum Discharge Voltage (kV crest) 8/20 $\mu$ s Current Wave					
			1.5 kA	3 kA	5 kA	10 kA	20 kA	40 kA
3	2.55	11	9	9.7	10.4	11.4	13	15.1
6	5.1	22	18.0	19.4	20.8	22.7	26	30.2
9	7.65	31.7	26.0	28	30	32.8	37.4	43.5
10	8.4	33	27.0	29.1	31.2	34.1	38.9	45.3
12	10.2	41.5	33.9	36.6	39.2	42.9	48.9	56.9
15	12.7	51.8	42.4	45.7	49	53.6	61.1	71.1
18	15.3	62.2	50.9	54.9	58.8	64.3	73.4	85.3
21	17	66	54.0	58.2	62.4	68.2	77.9	90.6
24	19.5	77	63.0	67.9	72.8	79.6	90.8	106
27	22	87.2	71.4	76.9	82.4	90.1	103	120
30	24.4	97.1	79.5	85.7	91.8	100	115	133
33	27	108	87.8	95.1	102	112	127	148
36	29	116	95.3	103	110	120	137	160

\*Based on 5 kA current impulse that results in a discharge voltage cresting in 0.5  $\mu$ s.

**TABLE 6**  
Protective Characteristics – VariSTAR Heavy-Duty (UHS) Arrester

Arrester Rating (kV rms)	MCOV (kV rms)	Front-of-wave Protective Level* (kV crest)	Maximum Discharge Voltage (kV crest) 8/20 $\mu$ s Current Wave					
			1.5 kA	3 kA	5 kA	10 kA	20 kA	40 kA
3	2.55	11	8.2	8.7	9.1	9.9	10.9	12.3
6	5.1	21.9	16.3	17.4	18.2	19.8	21.9	24.7
9	7.65	33	24.6	26.1	27.3	29.8	33	37.1
10	8.4	35	26	27.7	29	31.6	34.9	39.4
12	10.2	43.9	32.7	34.8	36.4	39.7	43.9	49.5
15	12.7	53.1	39.6	42.1	44	48	53.1	59.8
18	15.3	66	49.1	52.3	54.7	59.6	65.9	74.2
21	17	70	52.1	55.4	58	63.2	69.9	78.7
24	19.5	80.9	60.2	64.1	67	73.1	80.8	91.1
27	22	94	70	74.5	77.9	84.9	93.9	106
30	24.4	102	76.1	81	84.7	92.4	102	115
33	27	116	86.5	92.1	96.3	105	116	131
36	29	123	91.5	97.3	102	111	123	138

\*Based on 10 kA current impulse that results in a discharge voltage cresting in 0.5  $\mu$ s.

**TABLE 7**  
Protective Characteristics – VariSTAR Heavy-Duty Riser Pole (URS) Arrester

Arrester Rating (kV rms)	MCOV (kV rms)	Front-of-wave Protective Level* (kV crest)	Maximum Discharge Voltage (kV crest) 8/20 $\mu$ s Current Wave					
			1.5 kA	3 kA	5 kA	10 kA	20 kA	40 kA
3	2.55	10.3	7.7	8.2	8.6	9.4	10.3	11.7
6	5.1	20.7	15.5	16.4	17.2	18.7	20.7	23.3
9	7.65	29.8	22.3	23.7	24.7	27	29.8	33.6
10	8.4	31	23.2	24.6	25.7	28.1	31	35
12	10.2	39.1	29.2	31.1	32.4	35.4	39.1	44.1
15	12.7	48.7	36.4	38.7	40.4	44.1	48.8	54.9
18	15.3	58.4	43.7	46.4	48.5	52.9	58.5	65.9
21	17	62	46.4	49.3	51.5	56.2	62.1	70
24	19.5	72.3	54.1	57.5	60	65.5	72.4	81.6
27	22	81.4	60.9	64.7	67.6	73.8	81.6	91.9
30	24.4	91	68.1	72.4	75.6	82.5	91.2	103
33	27	100	75	79.7	83.3	90.9	100	113
36	29	108	80.6	85.6	89.4	97.6	108	122

\*Based on 10 kA current impulse that results in a discharge voltage cresting in 0.5  $\mu$ s.

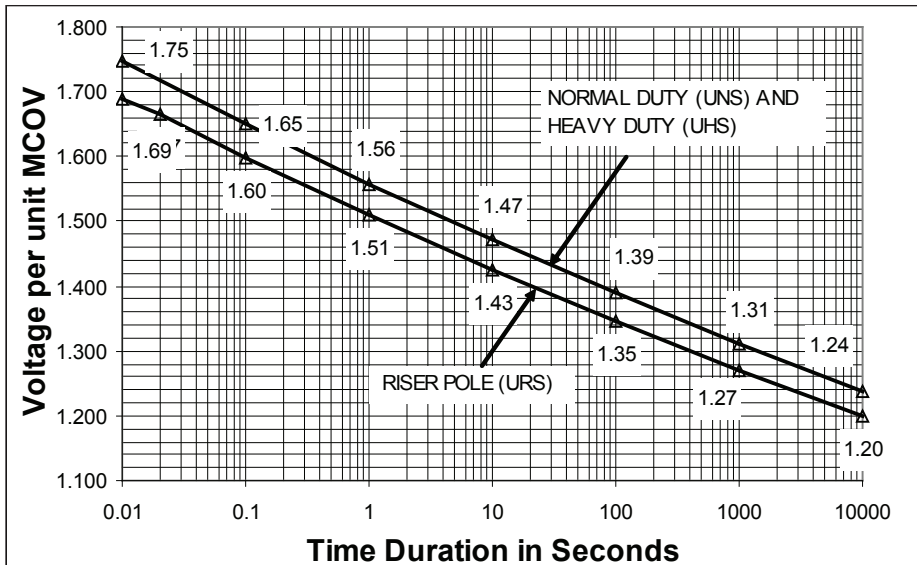

Figure 7. Temporary overvoltage curve. No prior duty – 60° C ambient.

### TEMPORARY OVERVOLTAGE (TOV) CAPABILITY

The ability to withstand 60 Hz overvoltage conditions [Temporary Overvoltage (TOV)] is shown in Figure 7 for all VariSTAR distribution-class arresters. The graph shows for a given voltage magnitude (on a Per Unit of MCOV basis), the time an arrester can survive a TOV condition without going into thermal runaway.

### ORDERING INFORMATION

VariSTAR distribution-class arresters from Cooper Power Systems are supplied in a variety of customer defined options. The catalog system employed lets the number define the features of the arrester. Table 8 shows the catalog numbers for several of the most common arrester styles. Table 9 shows what each alphanumeric character in the catalog number represents and lists several of the available options defined by these characters. A wide variety of option combinations are available, allowing users to customize the arrester to their specific needs. For further options contact your Cooper Power Systems sales engineer.

TABLE 8  
Catalog Numbers – VariSTAR Distribution-Class Surge Arresters

Arrester Rating	With Isolator and Insulated Hanger (Figure 3)	With Isolator, Insulated Hanger and NEMA Cross-Arm Bracket (Figure 4)	With Insulated Hanger Without Isolator (Figure 6)	With Isolator, Insulated Hanger and Transformer Mounting Bracket (Figure 5)
3	U★S0303-0A1A-1A1A	U★S0303-0A1A-1B1A	U★S0303-0A0A-1A1A	U★S0303-0A1C-1C1C
6	U★S0604-0A1A-1A1A	U★S0604-0A1A-1B1A	U★S0604-0A0A-1A1A	U★S0604-0A1C-1C1C
9	U★S0905-0A1A-1A1A	U★S0905-0A1A-1B1A	U★S0905-0A0A-1A1A	U★S0905-0A1C-1C1C
10	U★S1005-0A1A-1A1A	U★S1005-0A1A-1B1A	U★S1005-0A0A-1A1A	U★S1005-0A1C-1C1C
12	U★S1206-0A1A-1A1A	U★S1206-0A1A-1B1A	U★S1206-0A0A-1A1A	U★S1206-0A1C-1C1C
15	U★S1507-0A1A-1A1A	U★S1507-0A1A-1B1A	U★S1507-0A0A-1A1A	U★S1507-0A1C-1C1C
18	U★S1808-0A1A-1A1A	U★S1808-0A1A-1B1A	U★S1808-0A0A-1A1A	U★S1808-0A1C-1C1C
21	U★S2109-0A1A-1A1A	U★S2109-0A1A-1B1A	U★S2109-0A0A-1A1A	U★S2109-0A1C-1C1C
24	U★S2410-0A1A-1A1A	U★S2410-0A1A-1B1A	U★S2410-0A0A-1A1A	U★S2410-0A1C-1C1C
27	U★S2711-0A1A-1A1A	U★S2711-0A1A-1B1A	U★S2711-0A0A-1A1A	U★S2711-0A1C-1C1A
30	U★S3012-0A1A-1A1A	U★S3012-0A1A-1B1A	U★S3012-0A0A-1A1A	U★S3012-0A1C-1C1A
33	U★S3313-0A1A-1A1A	U★S3313-0A1A-1B1A	U★S3313-0A0A-1A1A	U★S3313-0A1C-1C1A
36	U★S3614-0A1A-1A1A	U★S3614-0A1A-1B1A	U★S3614-0A0A-1A1A	U★S3614-0A1C-1C1A

★ Digit 2 Option: **N** = Normal-Duty, **H** = Heavy-Duty, **R** = Riser Pole.  
 Note: All catalog numbers listed above include a universal wildlife protector.

**TABLE 9**  
**VariSTAR Distribution-Class Arrester UltraQUIK Catalog Numbering System**



**Catalog Number Digits**

1 = "U", UltraSIL Polymer-Housed Arrester

2 = Arrester Class:                    **N** = Normal-Duty                    **H** = Heavy-Duty                    **R** = Riser Pole

3 = Arrester Type:                    **S** = VariSTAR

4 & 5 = Arrester Rating:                    **03** = 3 kV (2.55 kV)                    **12** = 12 kV (10.2 kV)                    **21** = 21 kV (17.0 kV)                    **30** = 30 kV (24.4 kV)  
 Duty Cycle (MCOV)                    **06** = 6 kV (5.1 kV)                    **15** = 15 kV (12.7 kV)                    **24** = 24 kV (19.5 kV)                    **33** = 33 kV (27.0 kV)  
    **09** = 9 kV (7.65 kV)                    **18** = 18 kV (15.3 kV)                    **27** = 27 kV (22.0 kV)                    **36** = 36 kV (29.0 kV)  
    **10** = 10 kV (8.4 kV)

6 & 7 = Housing Code (Select from Table below):

**AVAILABLE HOUSINGS PER ARRESTER RATING**

★ = Standard Creepage Housing    ○ = Optional Creepage Housings

Digits 6 & 7	03	04	05	06	07	08	09	10	11	12	13	14	15	16	17
<b>Creep Length</b>	7.2"	10.1"	13.0"	15.9"	18.8"	21.7"	24.6"	27.5"	30.4"	33.3"	36.2"	39.1"	42.0"	44.9"	47.8"
<b>Arrester Rating (kV rms)</b>															
3	★	○													
6		★	○	○											
9			★	○	○	○									
10			★	○	○	○									
12				★	○	○	○	○							
15					★	○	○	○	○						
18						★	○	○	○	○					
21							★	○	○	○	○				
24								★	○	○	○	○			
27									★	○	○	○	○		
30										★	○	○	○	○	
33											★	○	○	○	○
36												★	○	○	○

8 = Line Terminal Wire:    0 = No Line Terminal Wire

1 = 12", #6 AWG Insulated Wire, Stripped 1.25" both ends

4 = 18", #6 AWG Insulated Wire, Stripped 1.25" both ends

7 = 30", #6 AWG Insulated Wire, Stripped 1.25" both ends

2 = 12", #6 AWG Insulated Wire, 1 ring terminal/1 end stripped 1.25"

5 = 18", #6 AWG Insulated Wire, 1 ring terminal/1 end stripped 1.25"

8 = 30", #6 AWG Insulated Wire, 1 ring terminal/1 end stripped 1.25"

3 = 12", #6 AWG Insulated Wire, 2 ring terminals

6 = 18", #6 AWG Insulated Wire, 2 ring terminals

9 = 30", #6 AWG Insulated Wire, 2 ring terminals

9 = Line Terminal Options

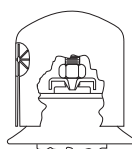
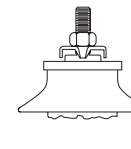
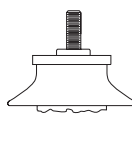
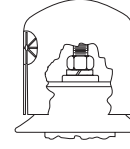
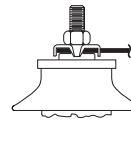
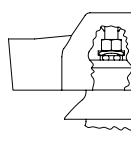
					
<b>A</b> = Silicon Bronze Nut, Stainless Steel Wire Clamp and Universal Wildlife Protector	<b>B</b> = Silicon Bronze Nut and Stainless Steel Wire Clamp	<b>C</b> = No Hardware	<b>D</b> = Silicon Bronze Nut, Lock Washer, Flat Washer and Universal Wildlife Protector (For leads with ring terminals)	<b>K</b> = Silicon Bronze Nut, Stainless Steel Wire Clamp, and Flipper Fuse Kit AM21A1 (See Page 10)	<b>X</b> = Silicon Bronze Nut, Stainless Steel Wire Clamp and CooperGuard. Reference Figure 9 for dimensional information.

**10 = Isolator**

**0** = No Isolator ( $\frac{3}{8}$ " Stainless Steel Grounding Stud only)

**1** = Black Isolator with  $\frac{3}{8}$ " Stainless Steel Grounding Stud

**2** = Red Isolator with  $\frac{3}{8}$ " Stainless Steel Grounding Stud

**3** = Yellow Isolator with  $\frac{3}{8}$ ", Stainless Steel Grounding Stud

**4** = Blue Isolator with  $\frac{3}{8}$ " Stainless Steel Grounding Stud

**5** = White Isolator with  $\frac{3}{8}$ " Stainless Steel Grounding Stud

**6** = Orange Isolator with  $\frac{3}{8}$ " Stainless Steel Grounding Stud

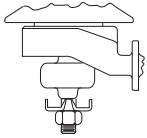
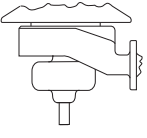
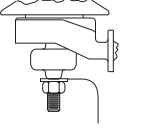
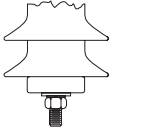

**11 = Ground Terminal Options**

 <p><b>A</b> = Wire Clamp with Silicon Bronze Nut (Shown with optional Isolator and Insulated Hanger)</p>	 <p><b>B</b> = No Hardware (Shown with optional Isolator and Insulated Hanger)</p>	 <p><b>C</b> = Copper Transformer Grounding Strap with Stainless Steel Lock Washer &amp; Silicone Bronze Nut (Shown with optional Isolator and Insulated Hanger)</p>	 <p><b>D</b> = Stainless Steel Washer, Lock Washer, Silicone Bronze Nut</p>
--	---	--	--

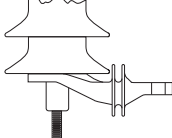
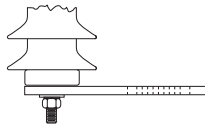
**12 = Base Configuration Options**

 <p><b>0</b> = Insulated Base (Base Mounted Arrester)</p>	 <p><b>1</b> = Insulated Hanger (Shown with optional Isolator)</p>	 <p><b>2</b> = Insulated Base With Conductive Mounting Strap (Requires "D" in Digit 11)</p>
--	---	--

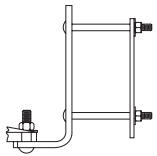
**13 = Mounting Bracket Options**

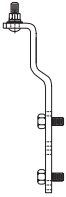
<p><b>A</b> = Without an Additional Mounting Bracket</p>	 <p><b>B</b> = NEMA Cross-Arm Bracket (Arrester Mounting Hardware Included) (Requires "1" or "2" in Digit 12) Refer to Figure 10 for dimensional information</p>	 <p><b>C</b> = Transformer Bracket (Arrester Mounting Hardware Included) (Requires "1" or "2" in Digit 12) Reference Figures 11 &amp; 12 for bracket dimensions</p>	 <p><b>D</b> = Option C Plus Transformer Mounting Hardware (2 each — <math>\frac{1}{2}</math>", 13-UNC x <math>\frac{3}{4}</math>" Bolts, Flat Washers, and Lock Washers) (Requires "1" or "2" in Digit 12)</p>
--	---	---	--

**14 = Nameplate Information: 1 = IEEE Std C62.11-2005™ standard Required Data**

**15 = Packaging:** **A** = Individual Carton (Assembled Terminal Hardware). Each arrester is shipped in an individual high strength cardboard carton. The top and bottom terminal hardware is assembled to the arrester. Any optional brackets or hardware are provided unassembled.

**C** = Bulk Packed (Assembled Terminal Hardware). Pallet sized bulk cardboard packaging for transformer mounting bracket options (Digits 13 = C or D only). Each arrester is shipped fully assembled including transformer mounting bracket. Available for 3-24 kV arresters only. Full pallet quantities only: 3-10 kV = 90, 12-18 kV = 72, 21-24 kV = 40.

**AVAILABLE ACCESSORIES  
FOR THE VARISTAR ARRESTER**

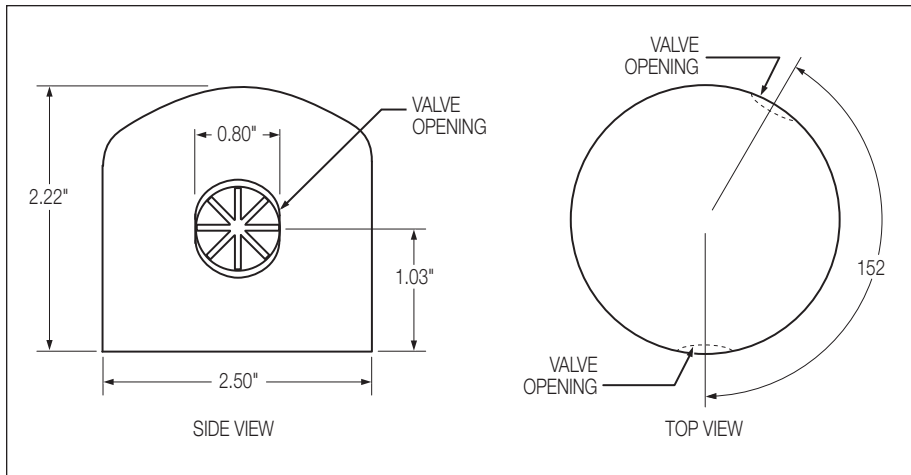

**Figure 8.**  
Universal wildlife protector (catalog number AV346X1).  
(All dimensions in inches).

**OPEN LINK FLIPPER  
FUSE KIT**

Customers who need an open-link flipper fuse kit without an arrester, can order this assembly separately. The kit includes the flipper arms (for the transformer bushing and arrester line terminal) and an optional bushing insulator cap. Table 10 lists the part numbers to order the flipper fuse kit. To order a VariSTAR arrester with flipper fuse assembly AM21A1 insert a "K" in digit 9 of the catalog number.

**TABLE 10**  
Flipper Fuse Kit Catalog Numbers

Description	Catalog Number
Flipper Fuse Kit with Bushing	AM 21A1
Flipper Fuse Kit without Bushing Wildlife Protector	AM21A2

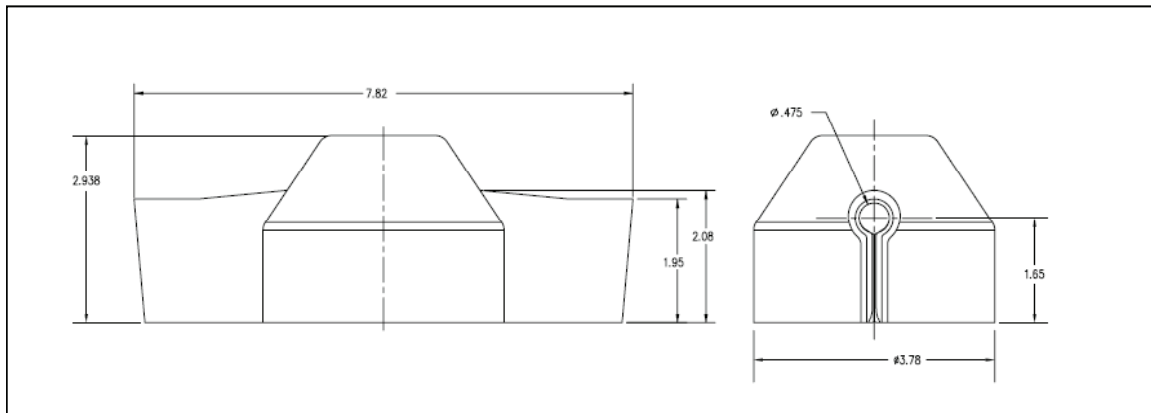

**Figure 9.**  
CooperGuard wildlife protector (catalog number AV698X1)  
(All dimensions in inches)

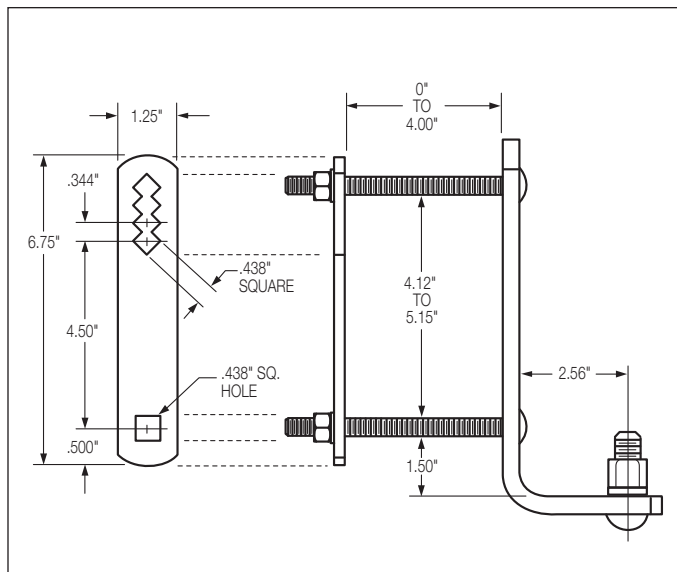

Figure 10. NEMA cross-arm bracket (catalog number AM35A1). (All dimensions in inches.)

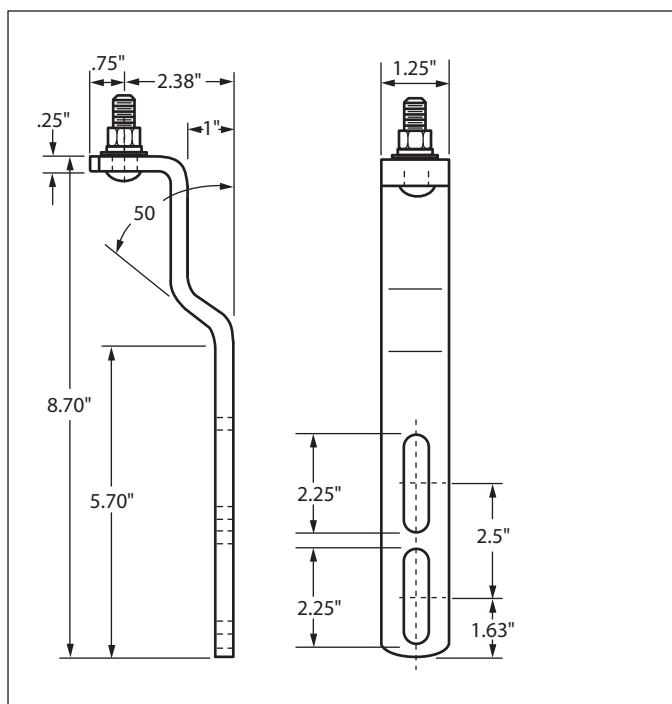

Figure 11. Standard transformer mounting bracket for 3-24 kV arrester (part number AM36A2). Can be specified with a "C" in Digit 13. (All dimensions in inches.)

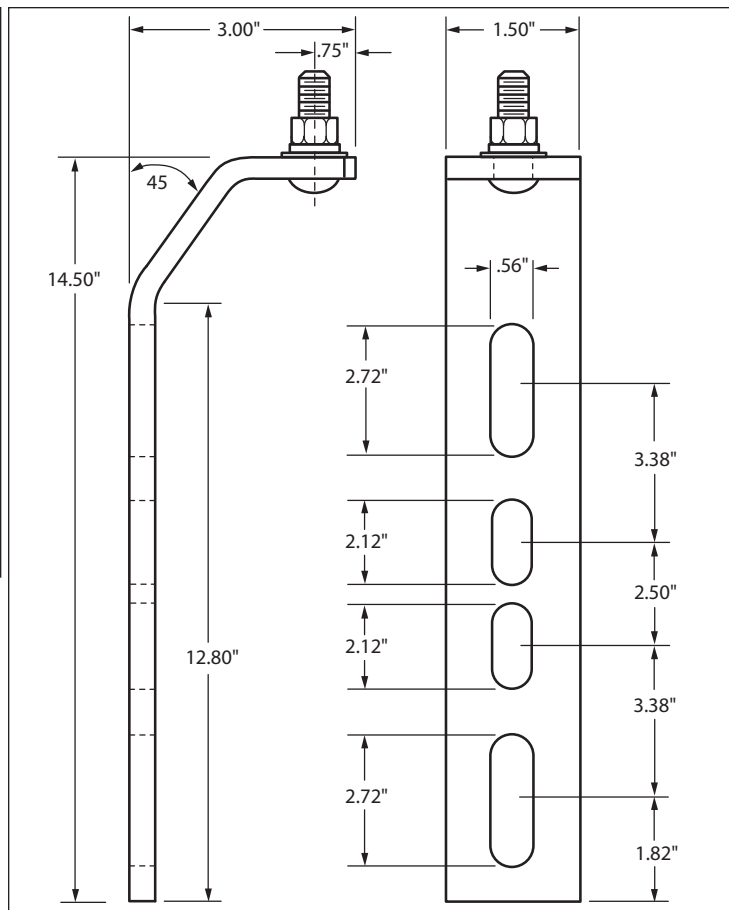

Figure 12. Standard transformer mounting bracket for 27-36 kV arrester (part number AH46A2). Can be specified with a "C" in Digit 13. (All dimensions in inches.)

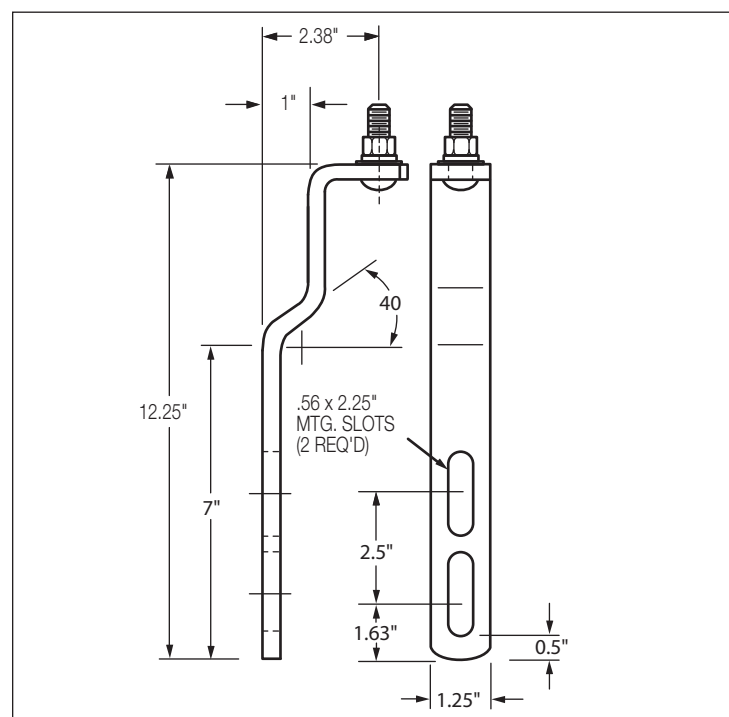
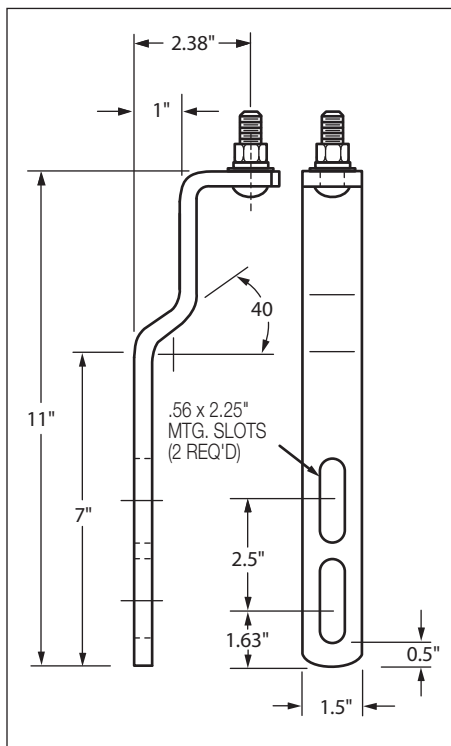

Figure 13. Optional transformer mounting bracket (catalog number AM36A3). Can be specified with an "N" in Digit 13. (All dimensions in inches.)



**Figure 14.**  
Optional transformer mounting bracket  
(catalog number AM36A1). Can be  
specified with an "S" in Digit 13. (All  
dimensions in inches.)

©2010 Cooper Industries. All Rights Reserved.  
Cooper Power Systems, VariSTAR, UltraSIL, UltraQUIK, and CooperGuard are  
valuable trademarks of Cooper Industries in the U.S. and other countries. You are not  
permitted to use the Cooper Trademarks without the prior written consent of Cooper  
Industries.

IEEE Std C62.11-2004™ standard and IEEE Std C62.22™ standard are trademarks of  
the Institute of Electrical and Electronics Engineers, Inc.  
IEEE is a registered trademark of the Institute of Electrical and Electronics Engineers,  
Inc., (IEEE). This publication/product is not endorsed or approved by the IEEE.

**COOPER** Power Systems

2300 Badger Drive  
Waukesha, WI 53188 USA  
www.cooperpower.com