

**VariSTAR Type AZE Surge Arresters
for Systems through 345 kV
IEEE Std C62.11™ standard Certified Station Class Arresters**

Electrical Apparatus
235-87

GENERAL

The VariSTAR AZE Surge Arrester offers the latest in metal oxide varistor (MOV) technology for the economical protection of power and substation equipment. This arrester is gapless and constructed of a single series column of MOV disks. The arrester is designed and tested to the requirements of IEEE Std C62.11™ standard and is available in ratings suitable for the transient overvoltage protection of electrical equipment on systems through 345 kV.

Cooper Power Systems assures the design integrity of the AZE arrester through a rigorous testing program conducted at our Thomas A. Edison Technical Center and at the factory in Olean, NY. The availability of complete "in-house" testing facilities assures that as continuous process improvements are made, they are professionally validated to high technical standards.

Table 1, shown below, contains information on some of the specific ratings and characteristics of AZE Series S (AXES) surge arresters.

**TABLE 1
AZE Series S (AZES) Ratings and Characteristics**

Arrester Characteristic	Rating
System Application Voltages	3-345 kV
Arrester Voltage Ratings	3-360 kV
Rated Discharge Energy, (kJ/ kV of MCOV)	
Arrester Ratings:	3.4
3-108 kV	5.6
120-240 kV	8.9
259-360 kV	
System Frequency	50/60 Hz
Impulse Classifying Current	10 kA
High Current Withstand	100 kA
Pressure Relief Rating, kA rms sym	
Metal-Top Designs	65 kA
Cubicle-Mount Designs	40 kA
Cantilever Strength (in-lbs)*	
Metal-Top Designs:	
3-240 kV	90,000
258-360 kV	120,000

* Maximum working load should not exceed 40% of this value.

CONSTRUCTION

External

The Type AZE station class arrester is available in two design configurations - a metal-top design in ratings 3-360 kV and a cubicle-mount design in ratings 3-48 kV. Cubicle-mount designs are ideally suited for confined spaces where clearances between live parts are limited.

The wet-process porcelain housing features an alternating shed design (ratings >48 kV) that provides excellent resistance to the effects of atmospheric housing contamination. AZE arresters are available with optional extra creepage porcelains for use in areas with extreme natural atmospheric and man-made pollution.

The dielectric properties of the porcelain are coordinated with the electrical protective characteristics of the arrester. The unit end castings are of a corrosion-resistant aluminum alloy configured for interchangeable mounting with other manufacturers' arresters for ease in upgrading to the VariSTAR arrester technology. This three-footed mounting is provided on a 8.75 to 10 inch diameter pattern for customer supplied 0.5 inch diameter hardware.

High Cantilever strength assures mechanical integrity (Table 1 lists the cantilever strength of metal-top AZES arresters). Cooper Power Systems recommends that a load limit of 100 pounds not be exceeded on the line terminal of cubicle mount designs. Loads exceeding this limit could cause a shortening of arrester life. Housings are available in standard grey or optional brown glaze color.

Standard line and ground terminal connectors accommodate up to a 0.75 inch diameter conductor. Insulating bases and discharge counters are optionally available for in-service monitoring of arrester discharge activity.

The end fittings and porcelain housing of each arrester unit are sealed and tested by means of a

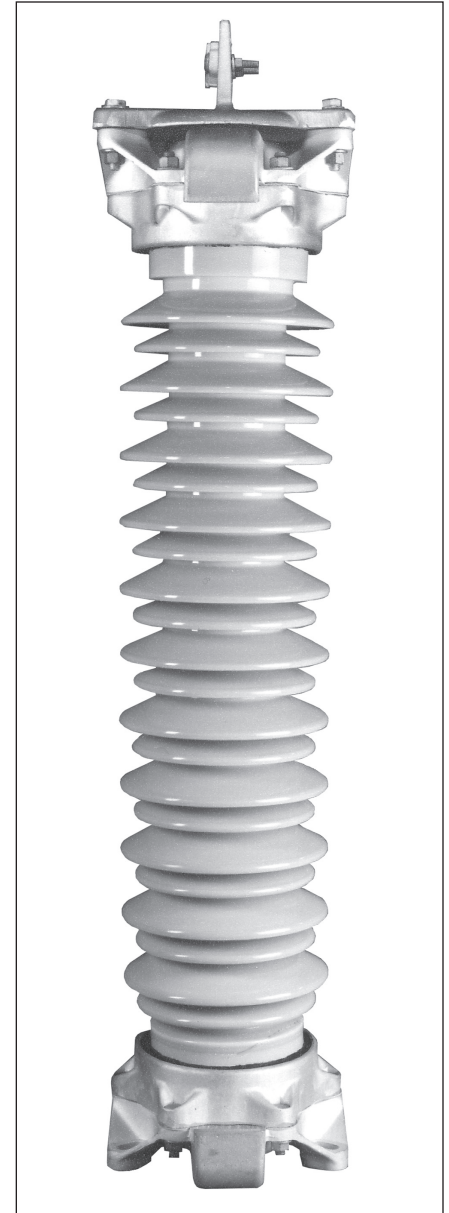

**Figure 1.
120 kV rated VariSTAR Type AZE surge arrester.**

sensitive helium mass spectrometer; this assures that the quality and insulation protection provided by the arrester is never compromised over its lifetime by the entrance of moisture. A corrosion-resistant nameplate is provided and contains all information required by Standards. In addition, stacking arrangement information is provided for multi-unit arresters. Voltage

grading rings are included for arresters rated 172 kV and above.

Internal

VariSTAR AZE arresters are a totally gapless MOV design. Gapless construction makes a significant contribution to the performance of arresters through the elimination of gap reseal as a consideration associated with the discharge of switching surge currents. The specially formulated metal-oxide varistors, manufactured under Cooper Power Systems exclusive quality control, provide exceptional non-linear protective characteristics, durability, and dependable energy dissipation capabilities.

OPERATION

The VariSTAR AZE arrester conducts only a few milliamperes of leakage current when energized at normal system voltage. When a surge event occurs, the arrester conducts only the current, and consequently the energy, necessary to limit the overvoltage. It provides precise and predictable protection, minimizes the absorbed energy, and does not discharge power frequency systems currents.

A controlled and directed pressure relief system is incorporated in the VariSTAR AZE arrester design. In the unlikely event of an arrester failure, this pressure venting system rapidly relieves internal pressure and transfers the internal arc to the outside of the arrester porcelain through vent ports in the end castings.

When called upon to operate, this mechanism vents internal pressures in fractions of a cycle-preventing violent arrester failure. This mechanism is effective to system fault currents up to 65 kA in metal-top designs and 40 kA in cubicle-mount designs.

GENERAL APPLICATION RECOMMENDATIONS

The rating of an arrester is the power-frequency line-to-ground voltage at which the arrester is designed to pass the IEEE Std C62.11™ standard duty-cycle test. Table 2 provides a general guide for the selection of the proper arrester for a given system voltage. Cooper Power Systems application engineers are available to make specific system application recommendations.

Selection of Arrester Rating

In arrester rating selection it is preferable to determine the lowest arrester rating that will ensure satisfactory operation. This is the optimum solution because the arrester selected will not only provide the greatest margin of insulation protection but also be the most economical choice.

Increasing the arrester rating above the minimum increases the likelihood of arrester survival during potential system contingencies, but compromises the protection of equipment insulation.

Rating selection should begin with consideration of the maximum system operating voltage. The maximum power frequency voltage expected under normal system conditions (line-to-ground) should not exceed the selected arrester's

maximum continuous operating voltage (MCOV).

The temporary overvoltage (TOV) capability of the VariSTAR AZE arrester is shown in Figure 3. The curves indicate the arrester's ability to withstand abnormal system power frequency (sinusoidal) overvoltages for various durations. The values shown assume that the arrester has been energized at MCOV prior to an overvoltage event and that the arrester is in an ambient temperature of 60°C. After the overvoltage durations shown, the arrester will thermally recover when once again energized at MCOV.

Figure 3 also illustrates the arrester's TOV capabilities with and without prior switching surge duties of up to the maximum capability of the arrester as listed in Table 1 (Rated Discharge Energy).

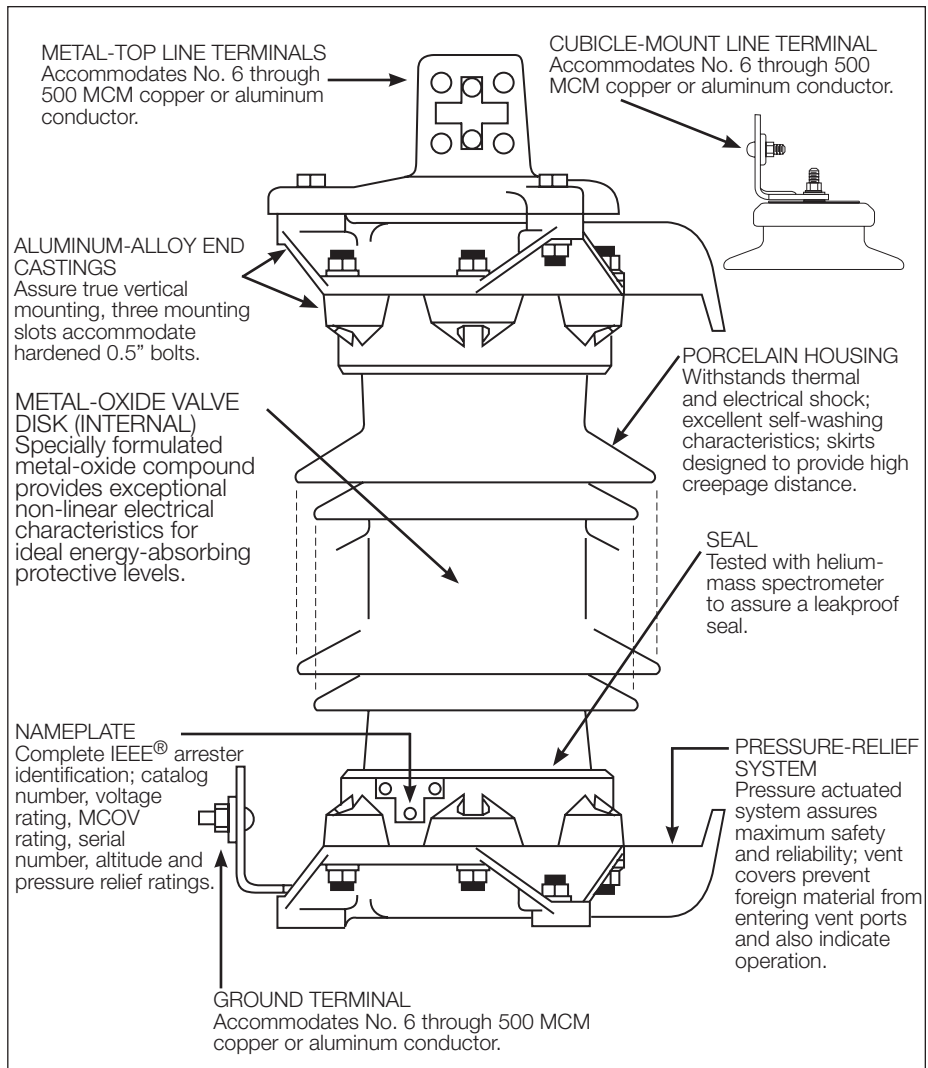

Figure 2. VariSTAR Type AZE arrester construction details.

It is not recommended that the TOV curve be extended for periods in excess of 10,000 seconds (2.8 hrs.).

For ungrounded systems, systems utilizing high impedance or resonant grounding and other systems where the line-to-ground voltage may be elevated to line-to-line voltages for extended periods, arresters having an MCOV equal to line-to-line voltage may be required.

For non-sinusoidal transient voltages caused by system switching operations, a transient network analyzer (TNA) study is recommended; Cooper Power Systems engineers are available to make these studies.

To assure proper application, the following information is normally required:

1. Maximum system operating voltage.
2. System grounding conditions.
 - A. For four-wire circuits, grounding conditions depend upon whether the system is multi-grounded, whether it has neutral impedance, and whether common primary and secondary neutrals are used.
 - B. For three-wire circuits, grounding conditions depend upon whether the system is solidly grounded at the source, grounded through neutral impedance at the source, grounded through transformers, or ungrounded.

Where unusual conditions exist (high ground resistance, high capacitive load, unusual switching surge duty, etc.) the following supplementary information is required.

1. Type of unusual condition.
2. BIL of equipment and separation distance to protected equipment.
3. Type of construction (phase spacing, length of line, conductor size, etc.).
4. Grounding and phase-sequence components of source impedances.
5. Phase-sequence components of load impedances.
6. Available fault current.
7. Potential for loss of neutral grounding during system events.

TABLE 2
Commonly Applied Voltage Ratings of the VariSTAR Type AZE Arrester

System Voltage (kV rms)		Suggested Arrester Rating (kV rms)	
Nominal	Maximum	Solidly Grounded Neutral Circuits	High Impedance Grounded, Ungrounded, or Temporarily Ungrounded Circuits
2.4	2.52		3
4.16	4.37	3	6
4.8	5.04		6
6.9	7.24		9
12.47	13.2	9-10	
13.2	14.0	10	15-18
13.8	14.5	10-12	15-18
20.7	21.8	15	
23.0	24.2		24-27
24.9	26.4	18-21	
27.6	29.0	21-24	27-30
34.5	36.5	27-30	36-39
46.0	48.3		48
69.0	72.5	54-60	66-72
115	121	90-96	108-120
138	145	108-120	132-144
161	169	120-144	144-168
230	242	172-192	228-240
345	362	258-312	288-360

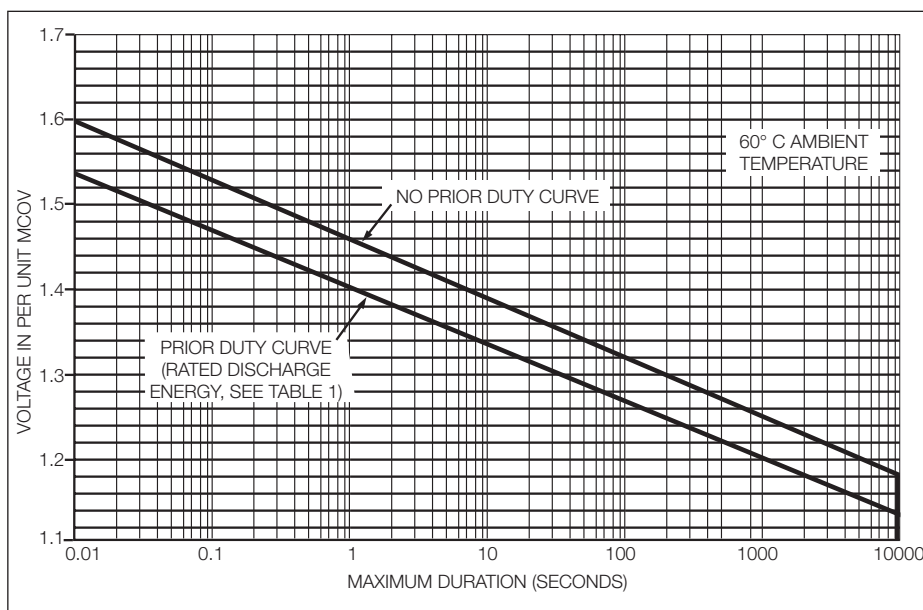

Figure 3.
Temporary overvoltage capability of VariSTAR AZE surge arresters.

ROUTINE TESTS

A complete production test program assures the quality of every VariSTAR AZE surge arrester. Each completed arrester is required to satisfactorily pass the following test regimen conducted in accordance with the procedures established in IEEE Std C62.11™ standard.

- Partial Discharge Test at 1.05 times MCOV.
- Power Frequency Test at 1.20 times MCOV.
- Discharge Voltage Test.
- Sealing Effectiveness Test of Housing by helium mass spectrometer.

STANDARDS

The VariSTAR AZE surge arrester has been tested and certified to IEEE Std C62.11™ standard. Guaranteed performance characteristics are specified in this catalog section and in the relevant “Design Certification Test Report” Cooper Power Systems bulletin 95028.

DIMENSIONS AND MOUNTING

Figure 4 illustrates an in-line mounting arrangement; the applicable minimum values of “B” and “C” may be found in Tables 4 and 5. Line and ground terminal details are shown in Figure 5; the supplied terminals accommodate

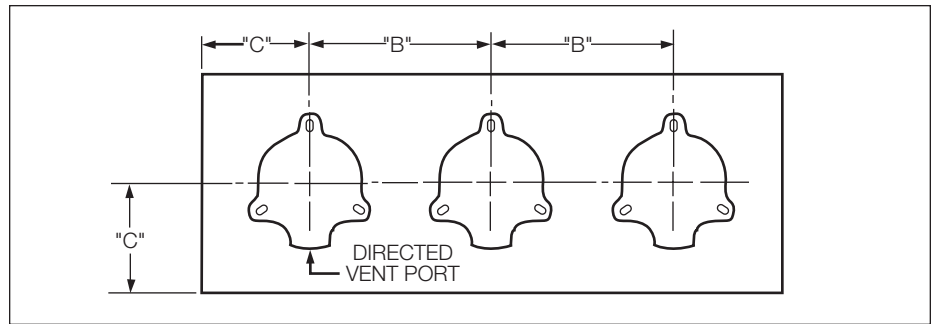

Figure 4.
Three-phase in-line mounting, top view.

Note: Refer to Tables 4 and 5 for Dimensions “B” and “C”.

aluminum and copper conductors to a maximum size of 0.75 inch.

For other conductors the terminal drilling pattern shown will accommodate industry standard two (2) and four (4) hole flat pad connectors having a 1.75 inch spacing. Figure 6 provides the dimensional details for universal base mounting.

The vent port in the base must be directed away from any adjacent equipment to control and prevent ionized gases from damaging other equipment in the unlikely event of arrester failure.

PERFORMANCE AND PROTECTIVE CHARACTERISTICS

Table 3 displays the Arrester Rating, Maximum Continuous Operating

Voltage (MCOV), and the guaranteed protective characteristics of the AZES surge arrester.

The Front-of-Wave protective level is the maximum discharge voltage for a 10 kA current impulse which results in a discharge voltage cresting in 0.5 microseconds. Lightning impulse Discharge Voltages represent the maximum voltage levels generated by the arrester when discharging lightning currents of the standard 8/20 microsecond wave-shape. The maximum Switching Impulse Discharge Voltages are based on a switching surge current having a time to crest of 45 to 60 microseconds.

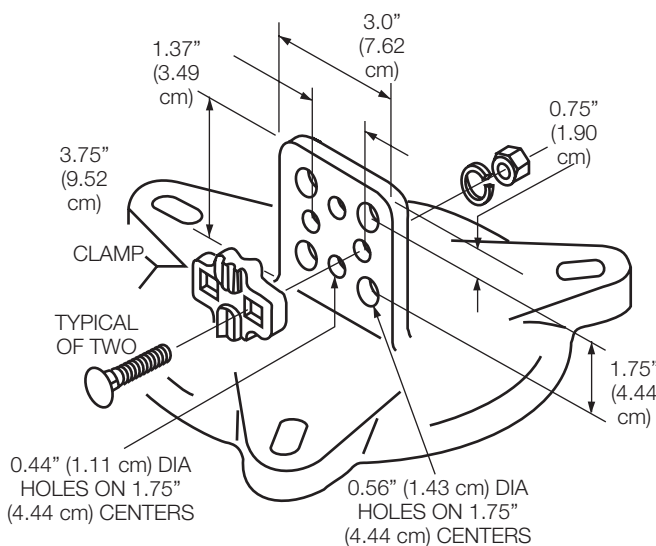

Line Terminal (Metal-Top Design)

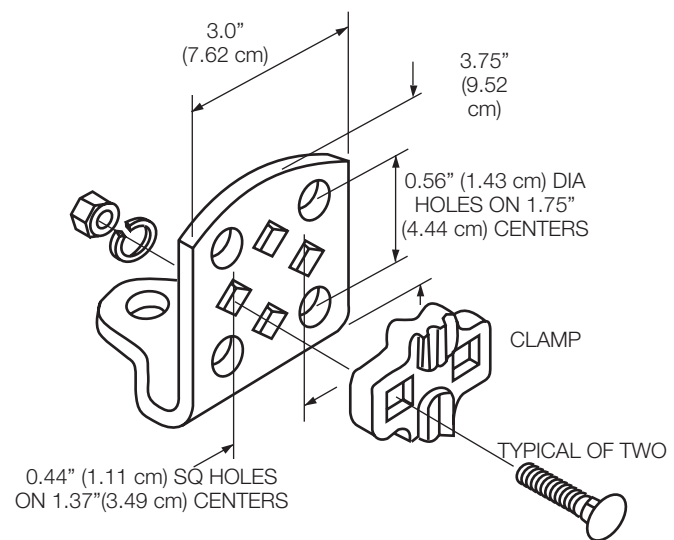

Ground Terminal (also Line Terminal for Cubicle-Mount Design)

Figure 5.
Line and ground terminals (suitable for copper or aluminum conductors up to 0.75” diameter).

TABLE 3
Discharge Voltages - Maximum Guaranteed Protective Characteristics for AZES Surge Arresters

Arrester Rating (kV rms)	Arrester MCOV (kV rms)	TOV* (kV rms)		Front-of-wave Protective Level** (kV Crest)	Maximum Discharge Voltage (kV crest) 8/20 μ s Current Wave						Switching Surge Protective Level*** (kV crest)				
		1 sec	10 sec		1.5 kA	3 kA	5 kA	10 kA	20 kA	40 kA	125 A	250 A	500 A	1000 A	2000A
3	2.55	3.73	3.56	9.3	7.0	7.4	7.7	8.4	9.4	11.0	6.1	6.3	6.5	6.7	
6	5.10	7.47	7.11	18.2	13.9	14.7	15.4	16.7	18.6	21.4	12.2	12.6	13.0	13.5	
9	7.65	11.2	10.7	27.2	20.9	22.0	23.1	25.0	27.7	31.7	18.3	18.9	19.5	20.2	
10	8.40	12.3	11.7	29.7	23.0	24.2	25.4	27.4	30.4	34.8	20.1	20.7	21.4	22.2	
12	10.2	14.9	14.2	36.0	27.9	29.4	30.8	33.3	36.9	42.1	24.4	25.2	26.0	26.9	
15	12.7	18.6	17.7	44.7	34.7	36.6	38.3	41.4	45.9	52.2	30.4	31.3	32.4	33.5	
18	15.3	22.4	21.3	53.7	41.8	44.0	46.2	49.8	55.2	62.8	36.6	37.7	39.0	40.4	
21	17.0	24.9	23.7	59.7	46.4	48.9	51.3	55.4	61.3	69.7	40.7	41.9	43.4	44.9	
24	19.5	28.6	27.2	68.4	53.3	56.1	58.8	63.5	70.3	79.9	46.7	48.1	49.8	51.5	
27	22.0	32.2	30.7	77.0	60.1	63.3	66.3	71.6	79.3	90.0	52.7	54.3	56.1	58.1	
30	24.4	35.7	34.0	85.4	66.6	70.2	73.6	79.4	87.9	99.8	58.4	60.2	62.3	64.4	
33	27.5	40.3	38.4	96.2	75.1	79.1	82.9	89.5	99.1	112	65.9	67.8	70.2	72.6	
36	29.0	42.5	40.5	101	79.2	83.4	87.4	94.4	105	119	69.5	71.5	74.0	76.6	
39	31.5	46.1	43.9	111	86.0	90.6	95.0	103	113	129	75.4	77.7	80.4	83.1	
42	34.0	49.8	47.4	119	92.8	97.8	103	111	122	139	81.4	83.9	86.8	89.7	
45	36.5	53.4	50.9	128	99.7	105	110	119	131	149	87.4	90.0	93.1	96.3	
48	39.0	57.1	54.4	136	107	112	118	127	140	159	93.4	96.2	99.5	103	
54	42.0	61.5	58.6	147	115	121	127	137	151	171	101	104	107	111	
60	48.0	70.3	67.0	167	131	138	145	156	173	196	115	118	123	127	
66	53.0	77.6	73.9	186	145	153	160	173	191	217	127	131	135	140	
72	57.0	83.5	79.5	200	156	164	172	186	205	233	137	141	145	151	
78	62.0	90.8	86.5	217	169	178	187	202	223	253	149	153	158	164	
84	68.0	99.6	94.9	237	186	196	205	221	245	278	163	168	174	179	
90	70.0	102.5	97.7	245	191	201	211	228	252	286	168	173	179	185	
96	76.0	111.3	106.0	265	208	219	229	247	274	310	182	188	194	201	
108	84.0	123.0	117.2	293	229	242	253	273	302	343	201	207	214	222	
120	98.0	143.5	136.7	321	255	269	279	298	328	366	226	232	238	247	
132	106	155.2	147.9	349	276	290	302	323	355	396	244	250	258	267	
138	111	162.5	154.9	365	289	304	316	338	372	415	256	262	270	280	
144	115	168.4	160.4	378	300	315	327	350	385	430	265	272	279	290	
162	130	190.3	181.4	427	339	356	370	396	435	486	300	307	316	327	
168	131	191.8	182.8	430	341	359	373	399	438	489	302	309	318	330	
172	140	205.0	195.3	459	365	384	398	426	468	523	323	331	340	352	
180	144	210.8	200.9	472	375	395	410	438	482	538	332	340	350	362	
192	152	222.5	212.0	499	396	417	432	463	509	568	350	359	369	383	
198	160	234.2	223.2	525	417	439	455	487	536	598	369	378	389	403	
204	165	241.6	230.2	541	430	452	469	502	552	617	380	390	401	415	
216	174	254.7	242.7	570	453	477	495	529	582	650	401	411	423	438	
228	180	263.5	251.1	591	469	493	512	548	602	672	415	425	437	453	
240	190	278.2	265.1	623	495	521	540	578	636	709	438	449	462	478	
258	209			684	547	568	580	605	666	771			502	526	535
264	212			693	555	576	588	613	675	782			509	533	543
276	220			720	575	598	611	637	701	811			528	553	563
288	230			751	602	625	639	665	732	848			552	578	589
294	235			767	615	639	652	679	748	866			564	591	602
300	239			781	625	650	663	691	761	881			574	601	612
312	245			801	630	655	669	709	780	903			578	606	617
330	267			872	698	726	741	772	850	985			641	671	683
336	269			879	704	731	747	778	856	991			645	676	689
360	289			945	756	785	802	836	920	1064			693	727	740

* Temporary overvoltage with prior duty energy surge.

** Based on a 10 kA current impulse that results in a discharge voltage cresting in a 0.5 μ s.

*** 45-60 μ s rise time current surge.

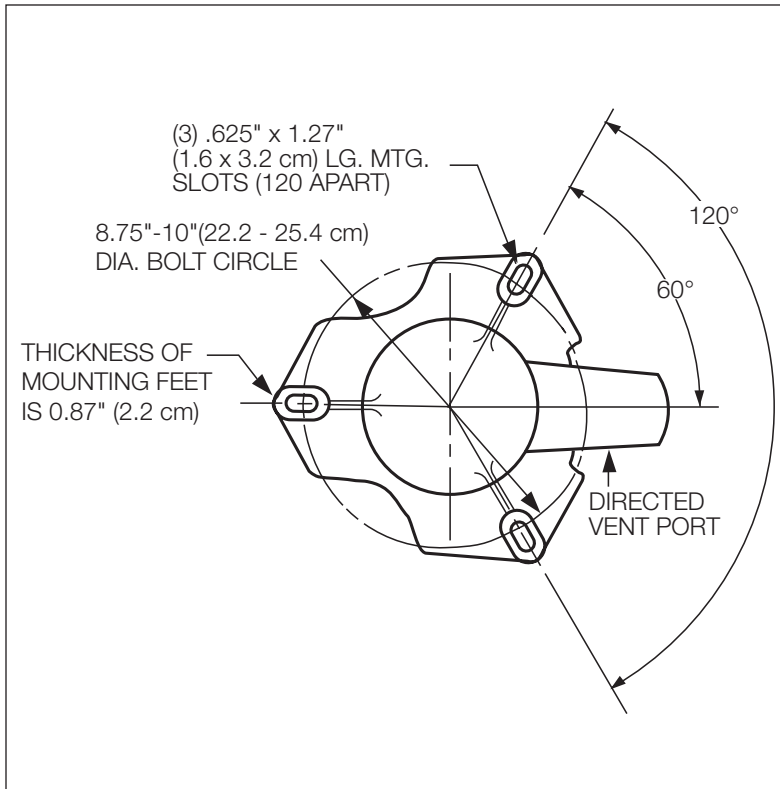

Figure 6.
Base mounting.

Note: To develop rated cantilever strength use 10 inch bolt circle mounting diameter and 0.5 inch hardened bolts and flat washers.

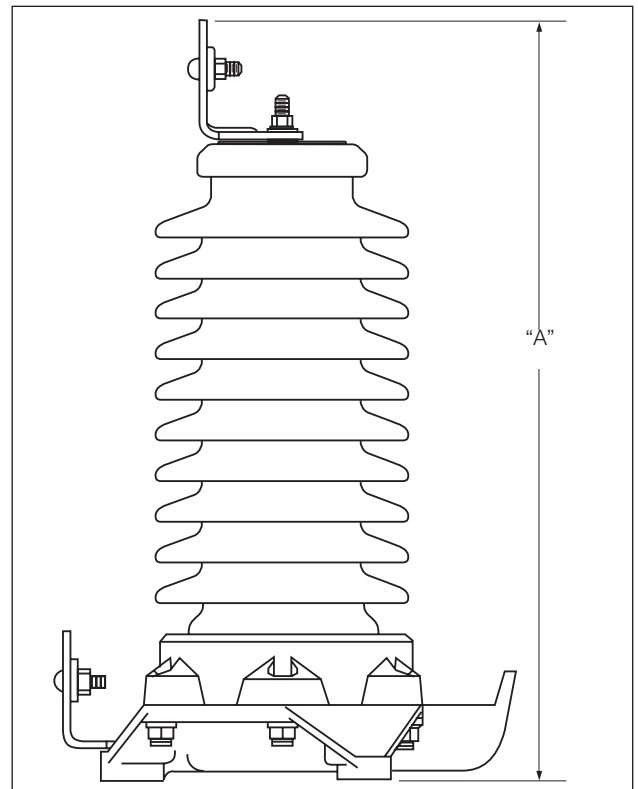

Figure 7.
Dimensions of VariSTAR Type AZE cubicle-mount surge arrester.

Note: Refer to Table 5 for dimension "A".

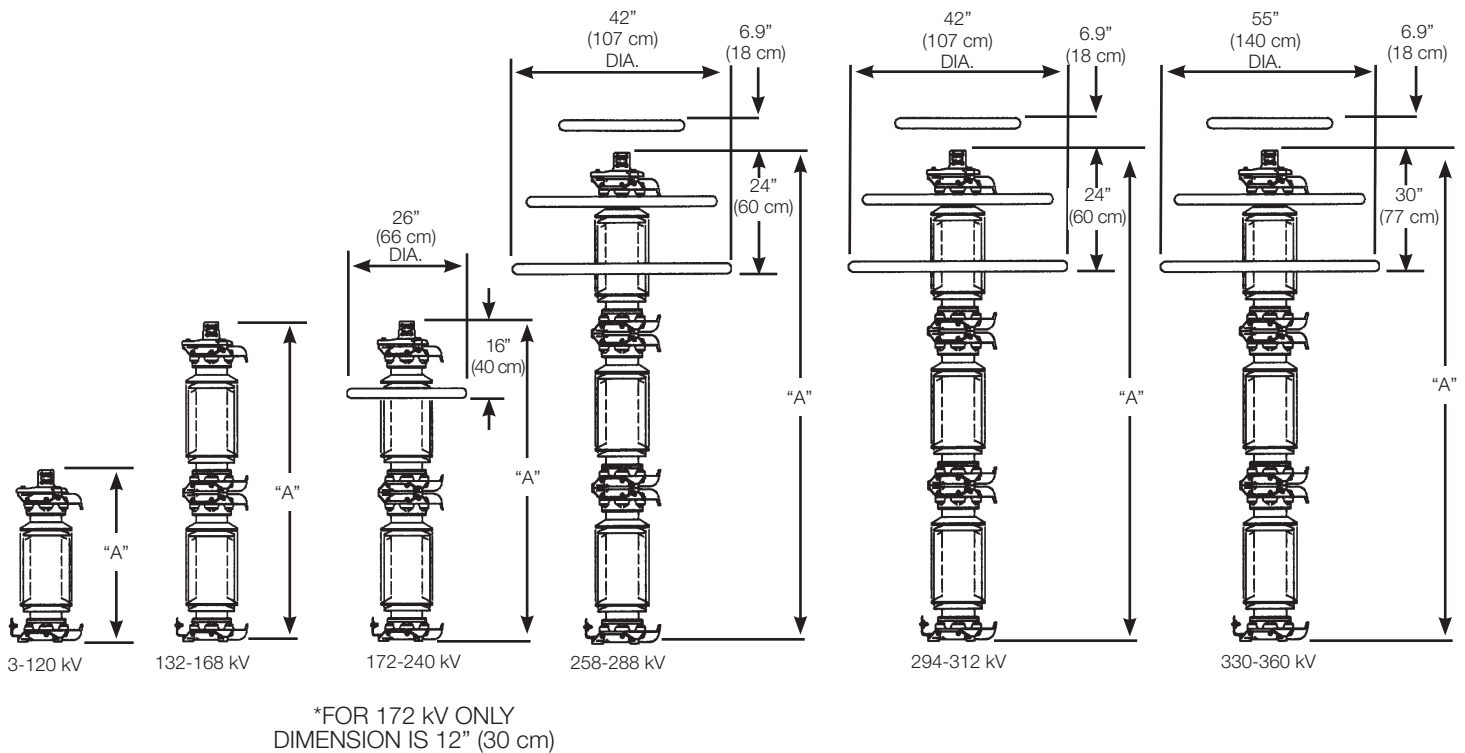

Figure 8.
Dimensions of VariSTAR Type AZE metal-top surge arresters.

Note: Refer to Table 4 for dimension "A".

TABLE 4
Catalog Numbers, Dimensional Information, Insulation Withstand Voltages and Weights for AZES Metal-Top Surge Arresters

Arrestor Rating (kV, rms)	Arrestor MCOV (kV, rms)	Catalog Number	Figure 8 Dim. "A" (in.)	Figure 4 Dim. "B" Minimum Phase-to-Phase Clearance (in.)	Figure 4 Dim. "C" Minimum Phase-to-Ground Clearance (in.)	Housing Leakage Distance (in.)	Housing Strike Distance (in.)	Insulation Withstand Voltages			Weight (lbs.)
								1.2/50 μ s Impulse (kV Crest)	60 Hz Dry, 60 sec (kV, rms)	60 Hz Wet, 10 sec (kV, rms)	
3	2.55	AZES001G002003	18.6	12	6	9.2	5.2	130	75	40	42
6	5.10	AZES001G005006	18.6	12	7	9.2	5.2	130	75	40	42
9	7.65	AZES001G007009	18.6	13	7	9.2	5.2	130	75	40	43
10	8.40	AZES002G008010	21.1	13	7	16.0	7.7	170	95	65	48
12	10.2	AZES002G010012	21.1	14	8	16.0	7.7	170	95	65	49
15	12.7	AZES002G012015	21.1	14	9	16.0	7.7	170	95	65	49
18	15.3	AZES003G015018	24.8	15	10	26.2	11.4	230	125	95	56
21	17.0	AZES003G017021	24.8	16	11	26.2	11.4	230	125	95	57
24	19.5	AZES003G019024	24.8	16	11	26.2	11.4	230	125	95	58
27	22.0	AZES004G022027	28.6	17	12	36.3	15.2	265	150	125	65
30	24.4	AZES004G024030	28.6	18	13	36.3	15.2	265	150	125	65
33	27.5	AZES004G027033	28.6	20	14	36.3	15.2	265	150	125	66
36	29.0	AZES004G029036	28.6	20	14	36.3	15.2	265	150	125	66
39	31.5	AZES005G031039	33.6	21	15	49.9	20.2	320	190	165	77
42	34.0	AZES005G034042	33.6	22	16	49.9	20.2	320	190	165	78
45	36.5	AZES005G036045	33.6	23	17	49.9	20.2	320	190	165	78
48	39.0	AZES005G039048	33.6	24	18	49.9	20.2	320	190	165	78
54	42.0	AZES006G042054	36.6	25	20	64.8	23.6	365	200	170	86
60	48.0	AZES006G048060	36.6	28	22	64.8	23.6	365	200	170	87
66	53.0	AZES007G053066	39.4	30	24	73.7	26.5	385	235	200	96
72	57.0	AZES007G057072	39.4	31	26	73.7	26.5	385	235	200	97
78	62.0	AZES008G062078	48.0	33	28	100.0	35.0	505	305	260	116
84	68.0	AZES008G068084	48.0	36	30	100.0	35.0	505	305	260	118
90	70.0	AZES008G070090	48.0	36	31	100.0	35.0	505	305	260	118
96	76.0	AZES008G076096	48.0	39	33	100.0	35.0	505	305	260	119
108	84.0	AZES009G084108	56.5	42	36	127.0	43.6	650	370	300	161
120	98.0	AZES009G098120	56.5	43	37	127.0	43.6	650	370	300	175
132	106	AZES012G106132	71.5	46	40	138.5	50.1	735	425	360	191
138	111	AZES012G111138	71.5	47	42	138.5	50.1	735	425	360	193
144	115	AZES013G115144	74.4	49	43	147.4	52.9	770	475	400	202
162	130	AZES014G130162	80.1	54	48	164.8	58.6	865	490	415	217
168	131	AZES015G131168	82.9	54	48	173.7	61.5	880	545	455	225
172	140	AZES021G140172	83.2	72	59	173.7	59.4	920	535	450	237
180	144	AZES022G144180	88.9	73	60	191.8	60.9	920	515	440	270
192	152	AZES022G152192	88.9	76	63	191.8	60.9	920	515	440	273
198	160	AZES023G160198	91.8	79	66	200.7	63.8	930	535	480	283
204	165	AZES024G165204	100.3	81	68	227.0	72.3	1065	595	545	303
216	174	AZES024G174216	100.3	84	71	227.0	72.3	1065	595	545	306
228	182	AZES025G182228	108.9	86	73	254.0	80.9	1185	655	580	348
240	190	AZES025G190240	108.9	89	76	254.0	80.9	1185	655	580	351
258	209	AZES067G209258	123.9	105	84	265.5	83.9	1265	690	625	472
264	212	AZES067G212264	123.9	106	85	265.5	83.9	1265	690	625	473
276	220	AZES069G220276	132.5	108	87	291.8	92.4	1300	750	675	499
288	230	AZES069G230288	132.5	111	90	291.8	92.4	1300	750	675	503
294	235	AZES070G235294	135.3	113	92	300.7	95.3	1405	765	725	524
300	239	AZES070G239300	135.3	114	93	300.7	95.3	1405	765	725	526
312	245	AZES071G245312	141.0	116	95	318.8	100.9	1475	805	730	558
330	267	AZES074G267330	152.4	136	108	354.0	109.5	1440	810	790	605
336	269	AZES074G269336	152.4	136	109	354.0	109.5	1440	810	790	606
360	289	AZES075G289360	161.0	143	115	381.0	118.0	1535	860	840	655

Note: All arresters are available in grey (standard) or brown porcelain glaze. For brown glaze, substitute "B" for "G" in the eighth position of the catalog number.

TABLE 5
Catalog Numbers, Dimensional Information, Insulation Withstand Voltages and Weights for AZES Cubicle-Mount Surge Arresters

Arrester Rating (kV, rms)	Arrester MCOV (kV, rms)	Catalog Number	Figure 7 Dim. "A" (in.)	Figure 4 Dim. "B" Minimum Phase-to-Phase Clearance (in.)	Figure 4 Dim. "C" Minimum Phase-to-Ground Clearance (in.)	Housing Leakage Distance (in.)	Housing Strike Distance (in.)	Insulation Withstand Voltages			Weight (lbs.)
								1.2/50 μ s Impulse (kV Crest)	60 Hz Dry, 60 sec (kV, rms)	60 Hz Wet, 10 sec (kV, rms)	
3	2.55	AZES091G002003	13.4	8	4	9.0	4.7	95	65	32	23
6	5.10	AZES091G005006	13.4	8	5	9.0	4.7	95	65	32	24
9	7.65	AZES091G007009	13.4	8	5	9.0	4.7	95	65	32	24
10	8.40	AZES092G008010	15.9	8	5	16.0	7.2	128	93	46	29
12	10.2	AZES092G010012	15.9	9	6	16.0	7.2	128	93	46	30
15	12.7	AZES092G012015	15.9	10	7	16.0	7.2	128	93	46	30
18	15.3	AZES093G015018	20.2	11	8	26.4	11.0	182	119	75	38
21	17.0	AZES093G017021	20.2	12	8	26.4	11.0	182	119	75	38
24	19.5	AZES093G019024	20.2	12	9	26.4	11.0	182	119	75	39
27	22.0	AZES094G022027	23.4	13	10	36.8	14.7	230	148	115	47
30	24.4	AZES094G024030	23.4	14	11	36.8	14.7	230	148	115	47
33	27.5	AZES094G027033	23.4	15	12	36.8	14.7	230	148	115	47
36	29.0	AZES094G029036	23.4	16	12	36.8	14.7	230	148	115	48
39	31.5	AZES095G031039	28.4	17	13	50.7	19.7	294	174	143	59
42	34.0	AZES095G034042	28.4	18	14	50.7	19.7	294	174	143	60
45	36.5	AZES095G036045	28.4	19	15	50.7	19.7	294	174	143	60
48	39.0	AZES095G039048	28.4	20	16	50.7	19.7	294	174	143	60

Note: All arresters are available in grey (standard) or brown porcelain glaze. For brown glaze, substitute "B" for "G" in the eighth position of the catalog number.

SUBJECT: VariSTAR® Type AZEH and AZEX, ANSI/IEEE C62.11
 Certified Station Class Surge Arresters - Data Sheets

TD-223

Cooper Power Systems offers the AZEH and AZEX line of Station Class surge arresters for customers who require higher energy handling than offered in our AZES product line. See Catalog Section 235-87 for details of the construction and application issues pertinent to all AZE surge arresters. This data sheet contains the electrical ratings, characteristics, and physical data specific to Type AZEH and AZEX surge arresters.

Table 1 below lists some of the ratings and characteristics specific to the AZEH and AZEX series of arresters.

Table 1. AZEH and AZEX Ratings and Characteristics

Arrester Characteristic	Rating	
	AZEH	AZEX
System Application Voltages	3-230 kV	3-138 kV
Arrester Duty - Cycle Ratings	3-240 kV	3-108 kV
Rated Discharge Energy (kJ/kV of MCOV) Arrester Duty-Cycle Rating: 3-108 kV 120-240 kV	5.6 8.9	8.9 -
Cantilever Strength (in-lbs)* Metal Top Design Duty-Cycle Ratings: 3-48 kV 54-108 kV 120-240 kV	90,000 90,000 120,000	90,000 120,000 -
System Frequency	50/60 Hz	50/60 Hz
Impulse Classifying Current	10 kA	10 kA
High Current Withstand	100 kA	100 kA
Pressure Relief Rating (rms sym) Metal Top Design (all ratings): Cubicle Mount Design (all ratings):	65 kA 40 kA	65 kA -
*1. Maximum working load should not exceed 40% of this value. 2. Terminal load limit for cubicle mount designs should not exceed 100 pounds. Excessive loading could lead to a shortened arrester life.		

The ability to withstand 60 Hz overvoltage conditions (Temporary Overvoltage (TOV)) is shown in Figure 1 for all VariSTAR AZE arresters. The graph shows for a given voltage magnitude (on a Per Unit of MCOV basis), the time an arrester can survive a TOV condition without going into thermal runaway.

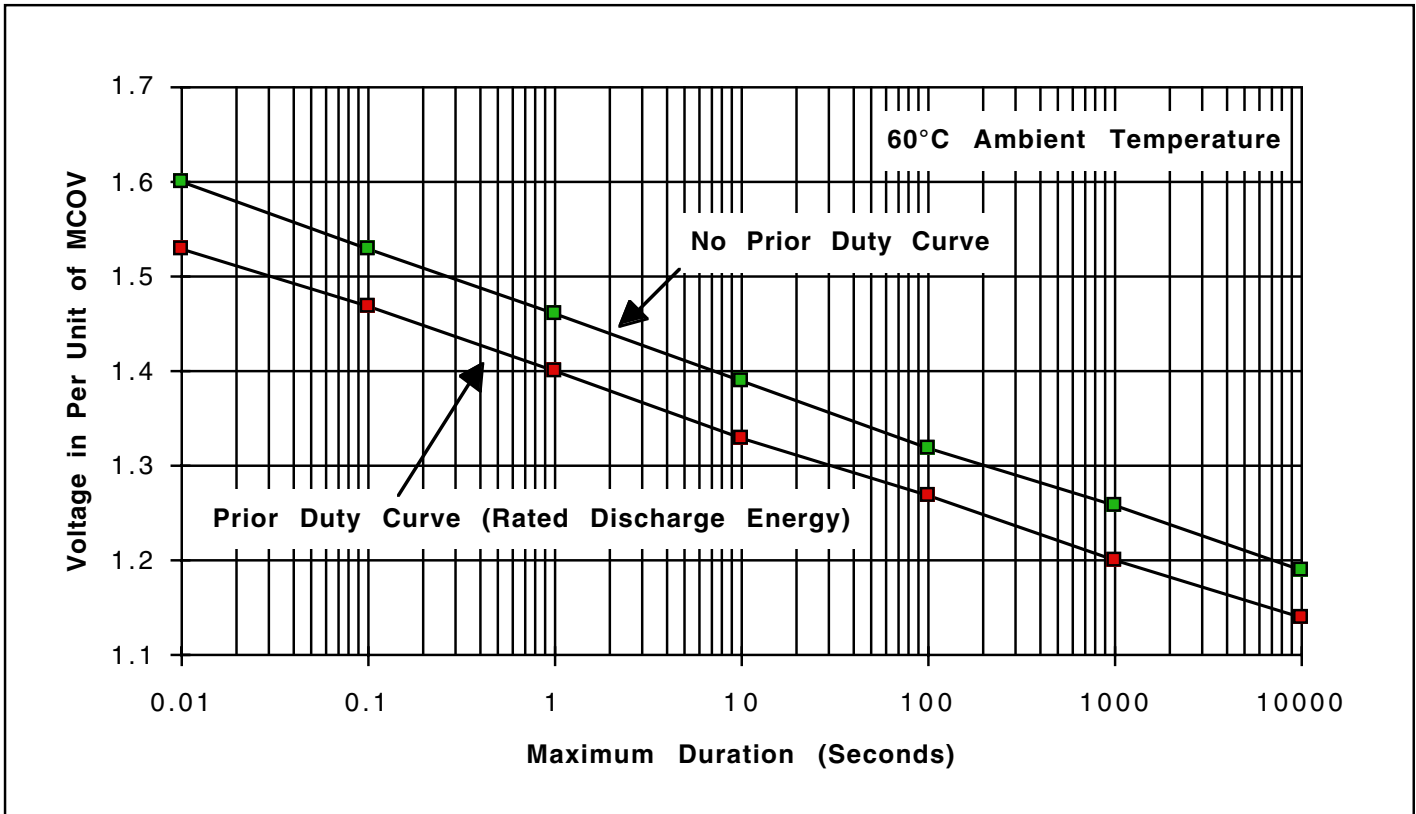

Figure 1. Temporary Overvoltage Capability of VariSTAR AZE Surge Arresters

Tables 2 and 3 list the maximum guaranteed protective characteristics of the AZEH and AZEX arresters respectively.

Table 2. Discharge Voltages - Maximum Guaranteed Protective Characteristics for Type AZEH Surge Arresters.

Arrester Rating (kV rms)	Arrester MCOV (kV, rms)	Front-of-Wave Protective Level (kV)*	Lightning Impulse Discharge Voltages (8/20 μ sec, kV)						Switching Impulse Discharge Voltages (kV)**		
			10 kA	1.5kA	3kA	5kA	10kA	20kA	40kA	500A	1000A
3	2.55	9.4	7.2	7.6	7.8	8.3	9.3	11.0	6.5	6.8	—
6	5.10	18.4	14.4	15.0	15.4	16.3	18.1	21.2	13.0	13.5	—
9	7.65	27.5	21.6	22.5	23.0	24.3	26.9	31.4	19.5	20.3	—
10	8.40	30.2	23.7	24.7	25.3	26.7	29.4	34.4	21.4	22.3	—
12	10.2	36.6	28.8	30.0	30.6	32.4	35.6	41.6	26.0	27.0	—
15	12.7	45.4	35.8	37.3	38.1	40.2	44.3	51.6	32.4	33.6	—
18	15.3	54.7	43.2	44.9	45.9	48.4	53.2	62.0	39.0	40.5	—
21	17.0	60.8	48.0	49.9	51.0	53.8	59.1	68.8	43.4	45.0	—
24	19.5	69.7	55.0	57.2	58.5	61.7	67.7	78.9	49.8	51.6	—
27	22.0	78.5	62.1	64.5	66.0	69.5	76.3	88.9	56.1	58.2	—
30	24.4	87.1	68.8	71.6	73.1	77.1	84.6	98.5	62.3	64.6	—
33	27.5	98.2	77.6	80.6	82.4	86.9	95.3	111	70.2	72.8	—
36	29.0	104	81.8	85.0	86.9	91.6	100	117	74.0	76.8	—
39	31.5	112	88.8	92.4	94.4	99.5	109	127	80.4	83.4	—
42	34.0	118	92.5	96.2	98.3	104	114	132	83.7	86.9	—
45	36.5	125	99.3	103	106	111	122	142	89.9	93.2	—
48	39.0	134	106	110	113	119	130	151	96.0	99.6	—
54	42.0	145	114	119	121	128	140	163	103	107	—
60	48.0	165	131	136	139	146	160	186	118	123	—
66	53.0	182	144	150	153	161	177	206	131	135	—
72	57.0	197	155	161	165	174	190	221	140	146	—
78	62.0	214	169	175	179	189	207	240	153	158	—
84	68.0	234	185	192	197	207	227	264	167	174	—
90	70.0	241	190	198	202	213	233	271	172	179	—
96	76.0	261	207	215	220	231	253	294	187	194	—
108	84.0	289	229	238	243	256	280	325	207	215	—
120	98.0	320	256	266	272	283	312	362	235	246	251
132	106	347	277	288	294	307	337	392	254	267	271
138	111	363	290	302	308	321	354	410	266	279	284
144	115	376	301	313	319	333	367	425	276	289	294
162	130	425	340	353	361	376	414	480	312	327	333
168	131	428	343	356	364	379	418	483	314	329	335
172	140	458	366	380	389	405	446	517	336	352	358
180	144	471	377	391	400	417	458	531	346	362	369
192	152	497	398	413	422	440	484	561	365	382	389
198	160	523	419	435	444	463	509	590	384	402	410
204	165	540	432	448	458	478	526	608	396	415	422
216	174	568	455	473	483	503	554	641	417	437	445
228	182	596	476	495	505	527	579	671	437	458	466
240	190	620	497	516	527	549	605	700	456	478	486

* Based on a current impulse that results in a discharge voltage in 0.5 μs.

** 45-60 μs rise time current surge.

Table 3. Discharge Voltages - Maximum Guaranteed Protective Characteristics for Type AZEX Surge Arresters.

Arrester Rating (kV, rms)	Arrester MCOV (kV, rms)	Front-of-Wave Protective Level (kV)*	Lightning Impulse Discharge Voltages (8/20 μ sec, kV)						Switching Impulse Discharge Voltages (kV)**		
			10 kA	1.5kA	3kA	5kA	10kA	20kA	40kA	500A	1000A
3	2.55	9.2	7.1	7.4	7.6	8.1	9.0	11.3	6.5	6.8	7.1
6	5.10	18.0	14.1	14.7	15.1	15.9	17.6	21.2	13.0	13.6	14.0
9	7.65	26.7	21.1	22.0	22.5	23.6	26.1	31.0	19.4	20.3	20.8
10	8.40	29.3	23.2	24.1	24.7	25.9	28.6	33.9	21.3	22.3	22.8
12	10.2	35.5	28.2	29.3	30.0	31.4	34.6	40.9	25.9	27.1	27.7
15	12.7	44.1	35.1	36.4	37.3	39.0	43.0	50.6	32.2	33.7	34.4
18	15.3	53.1	42.3	44.0	44.9	47.0	51.8	60.7	38.8	40.6	41.5
21	17.0	59.0	47.0	48.9	49.9	52.2	57.5	67.3	43.1	45.2	46.1
24	19.5	67.6	53.9	56.0	57.2	59.8	65.9	77.0	49.4	51.8	52.8
27	22.0	76.2	60.8	63.1	64.5	67.4	74.2	86.6	55.8	58.4	59.6
30	24.4	84.4	67.4	70.0	71.5	74.7	82.3	95.9	61.8	64.7	66.0
33	27.5	95.1	76.0	78.9	80.6	84.2	92.7	108	69.7	73.0	74.4
36	29.0	100	80.1	83.3	85.1	88.8	97.8	114	73.5	77.0	78.5
39	31.5	109	87.0	90.4	92.4	96.4	106	123	79.8	83.6	85.2
42	34.0	111	89.0	92.5	94.5	98.6	109	126	81.6	85.5	87.2
45	36.5	120	95.5	99.2	101	106	116	135	87.6	91.8	93.6
48	39.0	128	102	106	108	113	124	145	93.6	98.1	100
54	42.0	138	110	114	117	122	134	156	101	106	108
60	48.0	157	126	130	133	139	153	178	115	121	123
66	53.0	173	139	144	147	153	169	196	127	133	136
72	57.0	186	149	155	158	165	182	211	137	143	146
78	62.0	202	162	169	172	179	198	229	149	156	159
84	68.0	223	178	185	189	197	217	251	163	171	174
90	70.0	229	183	190	194	203	223	258	168	176	179
96	76.0	249	199	206	211	220	242	280	182	191	195
108	84.0	275	220	228	233	243	268	310	202	211	215

* Based on a current impulse that results in a discharge voltage in 0.5 μ s.

** 45-60 μ s rise time current surge.

Figure 2 illustrates an in-line mounting arrangement for a three-phase arrester application.

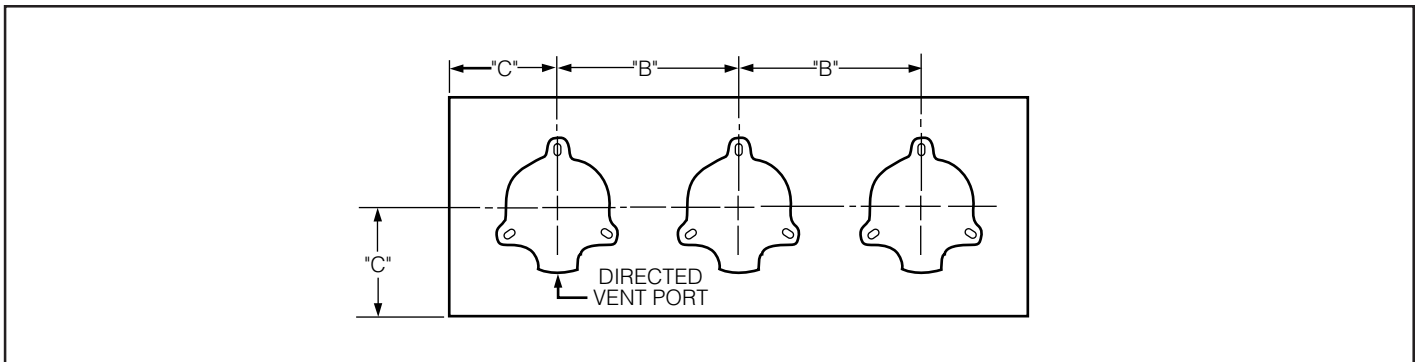

Figure 2. In-Line Mounting Arrangement for a Three-Phase Arrester Application

NOTE: Refer to Tables 4-6 for Dimensions "B" and "C".

Figures 3 and 4 show outline drawings of the AZEH and AZEX surge arresters.

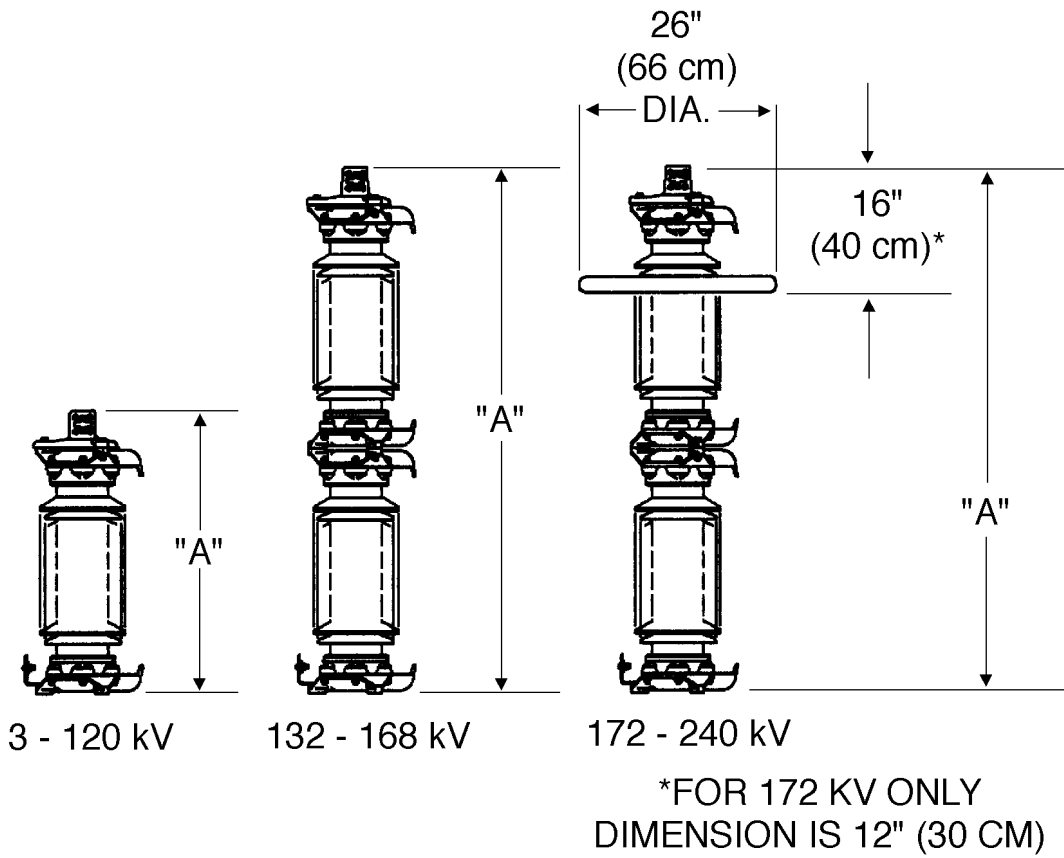

Figure 3. Outline Representations of VariSTAR Type AZE Metal Top Surge Arresters

NOTE: Refer to Tables 4 and 6 for Dimension "A".

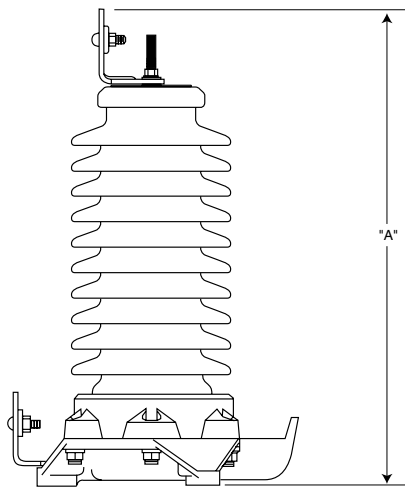

Figure 4. Outline Representation of VariSTAR Type AZEH Cubicle Mount Surge Arrester

NOTE: Refer to Table 5 for Dimension "A".

Table 4. Catalog Numbers, Dimensional Information, Insulation Withstand Voltages and Weights for AZEH Metal-Top Surge Arresters

Arrester Rating (kV, rms)	Arrester MCOV (kV, rms)	Catalog Number	Figure 3 Dim "A" (in)	Figure 2 Dim. "B" Minimum Phase-to-Phase Clearance (in)	Figure 2 Dim "C" Minimum Phase-to-Ground Clearance (in)	Housing Leakage Distance (in)	Housing Strike Distance (in)	Insulation Withstand Voltages			Weight (lbs)
								1.2/50 μ s Impulse (kV crest)	60 Hz Dry 60 sec (kV, rms)	60 Hz Wet, 10 sec (kV, rms)	
3	2.55	AZEH001G002003	18.2	12	6	9.2	5.2	130	75	40	42
6	5.10	AZEH001G005006	18.2	12	7	9.2	5.2	130	75	40	43
9	7.65	AZEH001G007009	18.2	13	7	9.2	5.2	130	75	40	44
10	8.40	AZEH002G008010	20.7	13	7	16.0	7.7	170	95	65	49
12	10.2	AZEH002G010012	20.7	13	8	16.0	7.7	170	95	65	50
15	12.7	AZEH002G012015	20.7	14	8	16.0	7.7	170	95	65	51
18	15.3	AZEH003G015018	25.0	15	9	26.2	11.4	230	125	95	58
21	17.0	AZEH003G017021	25.0	16	10	26.2	11.4	230	125	95	59
24	19.5	AZEH003G019024	25.0	16	10	26.2	11.4	230	125	95	60
27	22.0	AZEH004G022027	28.2	17	11	36.3	15.2	265	150	125	68
30	24.4	AZEH004G024030	28.2	18	12	36.3	15.2	265	150	125	68
33	27.5	AZEH004G027033	28.2	19	13	36.3	15.2	265	150	125	69
36	29.0	AZEH004G029036	28.2	19	13	36.3	15.2	265	150	125	70
39	31.5	AZEH005G031039	33.2	20	14	49.9	20.2	320	190	165	81
42	34.0	AZEH005G034042	33.2	21	15	49.9	20.2	320	190	165	82
45	36.5	AZEH005G036045	33.2	21	16	49.9	20.2	320	190	165	83
48	39.0	AZEH005G039048	33.2	22	17	49.9	20.2	320	190	165	83
54	42.0	AZEH006G042054	36.6	23	18	64.8	23.6	365	200	170	90
60	48.0	AZEH006G048060	36.6	25	20	64.8	23.6	365	200	170	92
66	53.0	AZEH007G053066	39.4	27	21	73.8	26.5	385	235	200	102
72	57.0	AZEH007G057072	39.4	28	23	73.8	26.5	385	235	200	103
78	62.0	AZEH008G062078	48.0	30	25	100	35.0	505	305	260	123
84	68.0	AZEH008G068084	48.0	32	27	100	35.0	505	305	260	125
90	70.0	AZEH008G070090	48.0	33	27	100	35.0	505	305	260	125
96	76.0	AZEH008G076096	48.0	35	29	100	35.0	505	305	260	127
108	84.0	AZEH009G084108	56.5	38	32	127	43.6	650	370	300	170
120	98.0	AZEH049G098120	56.5	39	34	127	44.2	650	370	300	213
132	106	AZEH052G106132	71.5	42	36	139	51.3	735	425	360	244
138	111	AZEH052G111138	71.5	44	38	139	51.3	735	425	360	247
144	115	AZEH053G115144	74.4	45	39	147	54.1	770	475	400	258
162	130	AZEH054G130162	80.1	49	44	165	59.8	865	490	415	276
168	131	AZEH055G131168	83.0	50	44	174	62.7	880	545	455	289
172	140	AZEH061G140172	83.0	67	54	174	60.0	920	535	450	301
180	144	AZEH062G144180	88.6	68	55	192	61.6	920	515	440	332
192	152	AZEH062G152192	88.6	71	58	192	61.6	920	515	440	336
198	160	AZEH063G160198	91.5	73	60	201	64.4	930	535	480	349
204	165	AZEH064G165204	100	75	62	227	73.0	1065	595	545	374
216	174	AZEH064G174216	100	78	65	227	73.0	1065	595	545	378
228	182	AZEH065G182228	109	80	67	254	81.5	1285	655	580	423
240	190	AZEH065G190240	109	83	70	254	81.5	1285	655	580	426

NOTES:

1. All arresters are available in grey (standard) or brown porcelain glaze. For brown glaze, substitute "B" for "G" in the eighth position of the catalog.

Table 5. Catalog Numbers, Dimensional Information, Insulation Withstand Voltages and Weights for AZEH Cubicle Mount Surge Arresters

Arrestor Rating (kV, rms)	Arrestor MCOV (kV, rms)	Catalog Number	Figure 4 Dim "A" (in)	Figure 2 Dim. "B" Minimum Phase-to-Phase Clearance (in)	Figure 2 Dim "C" Minimum Phase-to-Ground Clearance (in)	Housing Leakage Distance (in)	Housing Strike Distance (in)	Insulation Withstand Voltages			Weight (lbs)
								1.2/50 μ s Impulse (kV crest)	60 Hz Dry 60 sec (kV, rms)	60 Hz Wet, 10 sec (kV, rms)	
3	2.55	AZEH091G002003	13.4	8	4	9.0	4.7	95	65	32	23
6	5.10	AZEH091G005006	13.4	8	5	9.0	4.7	95	65	32	24
9	7.65	AZEH091G007009	13.4	8	5	9.0	4.7	95	65	32	25
10	8.40	AZEH092G008010	15.9	8	5	16.0	7.2	128	93	46	30
12	10.2	AZEH092G010012	15.9	9	5	16.0	7.2	128	93	46	31
15	12.7	AZEH092G012015	15.9	10	6	16.0	7.2	128	93	46	32
18	15.3	AZEH093G015018	20.2	10	7	26.4	11.0	182	119	75	39
21	17.0	AZEH093G017021	20.2	11	8	26.4	11.0	182	119	75	40
24	19.5	AZEH093H019024	20.2	11	8	26.4	11.0	182	119	75	41
27	22.0	AZEH094G022027	23.4	12	9	36.8	14.7	230	148	115	49
30	24.4	AZEH094G024030	23.4	13	10	36.8	14.7	230	148	115	49
33	27.5	AZEH094G027033	23.4	14	11	36.8	14.7	230	148	115	50
36	29.0	AZEH094G029036	23.4	15	11	36.8	14.7	230	148	115	51
39	31.5	AZEH095G031039	28.4	16	12	50.7	19.7	294	174	143	63
42	34.0	AZEH095G034042	28.4	16	13	50.7	19.7	294	174	143	64
45	36.5	AZEH095G036045	28.4	17	14	50.7	19.7	294	174	143	65
48	39.0	AZEH095G039048	28.4	18	15	50.7	19.7	294	174	143	65

NOTES:

1. All arresters are available in grey (standard) or brown porcelain glaze. For brown glaze, substitute "B" for "G" in the eighth position of the catalog.

Table 6. Catalog Numbers, Dimensional Information, Insulation Withstand Voltages and Weights for AZEX Metal-Top Surge Arresters

Arrester Rating (kV, rms)	Arrester MCOV (kV, rms)	Catalog Number	Figure 3 Dim "A" (in)	Figure 2 Dim. "B" Minimum Phase-to-Phase Clearance (in)	Figure 2 Dim "C" Minimum Phase-to-Ground Clearance (in)	Housing Leakage Distance (in)	Housing Strike Distance (in)	Insulation Withstand Voltages			Weight (lbs)
								1.2/50 μ s Impulse (kV crest)	60 Hz Dry 60 sec (kV, rms)	60 Hz Wet, 10 sec (kV, rms)	
3	2.55	AZEX041G002003	18.2	12	6	9.2	5.7	130	75	40	41
6	5.10	AZEX041G005006	18.2	12	6	9.2	5.7	130	75	40	43
9	7.65	AZEX041G007009	18.2	12	7	9.2	5.7	130	75	40	44
10	8.40	AZEX042G008010	20.7	13	7	16.0	8.2	170	95	65	50
12	10.2	AZEX042G010012	20.7	13	7	16.0	8.2	170	95	65	52
15	12.7	AZEX042G012015	20.7	14	8	16.0	8.2	170	95	65	53
18	15.3	AZEX043G015018	25.0	14	9	26.2	11.9	230	125	95	63
21	17.0	AZEX043G017021	25.0	15	9	26.2	11.9	230	125	95	64
24	19.5	AZEX043G019024	25.0	15	9	26.2	11.9	230	125	95	66
27	22.0	AZEX044G022027	28.2	16	10	36.3	15.7	265	150	125	77
30	24.4	AZEX044G024030	28.2	17	11	36.3	15.7	265	150	125	77
33	27.5	AZEX044G027033	28.2	18	12	36.3	15.7	265	150	125	78
36	29.0	AZEX044G029036	28.2	18	13	36.3	15.7	265	150	125	80
39	31.5	AZEX045G031039	33.2	19	13	49.9	20.7	320	190	165	94
42	34.0	AZEX045G034042	33.2	19	14	49.9	20.7	320	190	165	96
45	36.5	AZEX045G036045	33.2	20	14	49.9	20.7	320	190	165	97
48	39.0	AZEX045G039048	33.2	21	15	49.9	20.7	320	190	165	97
54	42.0	AZEX046G042054	36.6	22	16	64.8	24.2	365	200	170	114
60	48.0	AZEX046G048060	36.6	24	18	64.8	24.2	365	200	170	116
66	53.0	AZEX047G053066	39.4	25	20	73.7	27.1	385	235	200	129
72	57.0	AZEX047G057072	39.4	27	21	73.7	27.1	385	235	200	131
78	62.0	AZEX048G062078	48.0	28	22	100	35.6	505	305	260	156
84	68.0	AZEX048G068084	48.0	30	24	100	35.6	505	305	260	158
90	70.0	AZEX048G070090	48.0	31	25	100	35.6	505	305	260	158
96	76.0	AZEX048G076096	48.0	32	27	100	35.6	505	305	260	161
108	84.0	AZEX049G084108	56.5	35	29	127	44.2	650	370	300	206

NOTES:

1. All arresters are available in grey (standard) or brown porcelain glaze. For brown glaze, substitute "B" for "G" in the eighth position of the catalog.