

Fusing Equipment

Electrical Apparatus-
240-60

NX Indoor Current-Limiting Fuses

GENERAL

Cooper Power Systems Type NX current-limiting fuses provide overload protection for all indoor and underground cable distribution systems 2.4 through 38 kV. NX fuses are noiseless and expel no hot gases or burning particles while interrupting currents from minimum melt to maximum fuse rating (50,000 A through 23 kV, 35,000 A through 27 and 38 kV). Their current-limiting capability greatly reduces the momentary duty on protected equipment, extending the life and, in some cases, reducing the original cost of that equipment.

The ability of an NX fuse to interrupt low-current faults eliminates the need for auxiliary devices to handle these troublesome current levels. An NX fuse extends system coordination because it is fast clearing and current-limiting – conductor and equipment damage caused by high currents is virtually eliminated.

Clip-Style NX Fuse

The basic NX fuse unit (see Figure 1) is designed to mount in a McGraw-Edison clip-style mounting. Basic clip-style NX fuses are available in 4.3, 5.5, 8.3, 15.5, 23, 27, and 38 kV ratings.

NX Fuse with Arc-Strangler® Loadbreak Device

An NX fuse with an Arc-Strangler loadbreaking device, (see Figure 2) that mounts in a hinge-style mounting is available on 4.3, 5.5, 8.3, and 15.5 kV fuses. All current magnitudes from excitation current through 200 A can be interrupted positively and safely by opening the fuse with a switchstick.

These units have the same operating characteristics as the basic clip-style fuse, along with loadbreaking capabilities.

Arc-Strangler Switchblade

Switchblades with the Arc-Strangler loadbreaking device are available in 8.3 and 15.5 kV, 200 A continuous current ratings (see Figure 3).



Figure 1. Clip-style NX fuses.



Figure 2. NX fuse with Arc-Strangler loadbreaking device.

TABLE 1
Electrical Characteristics

Fuse Type	Full Range
Maximum Interrupting	50,000 A through 2.4 and 23 kV
Current (symmetrical)	35,000 A through

TABLE 2
NX Fuse Time Current Characteristic (TCC) Curves

Voltage Rating (kV)	TCC Curve
4.3	R240-91-30
5.5	R240-91-31
8.3	R240-91-32
15.5	R240-91-33
23	R240-91-34
27.38	R240-91-35

INSTALLATION

The NX clip- and hinge-style fuses are designed to fit industry standard mountings. Each fuse is marked with its mounting code number. The mounting code number defines the mounting's insulation level, contact spacing and contact type. NX clip-style fuses fit 5/8" standard clip-style mountings in pad-mounted transformers, switchgear, sectionalizing enclosures, industrial vaults, and metal



Figure 3. Arc-Strangler switchblade.

clad switchgear. The NX hinge-style fuses fit the standard hinge-style mountings. The mounting code number of the fuse and the mount must be the same. Refer to catalog section 240-59, for more detailed information on clip- and hinge-style mountings.

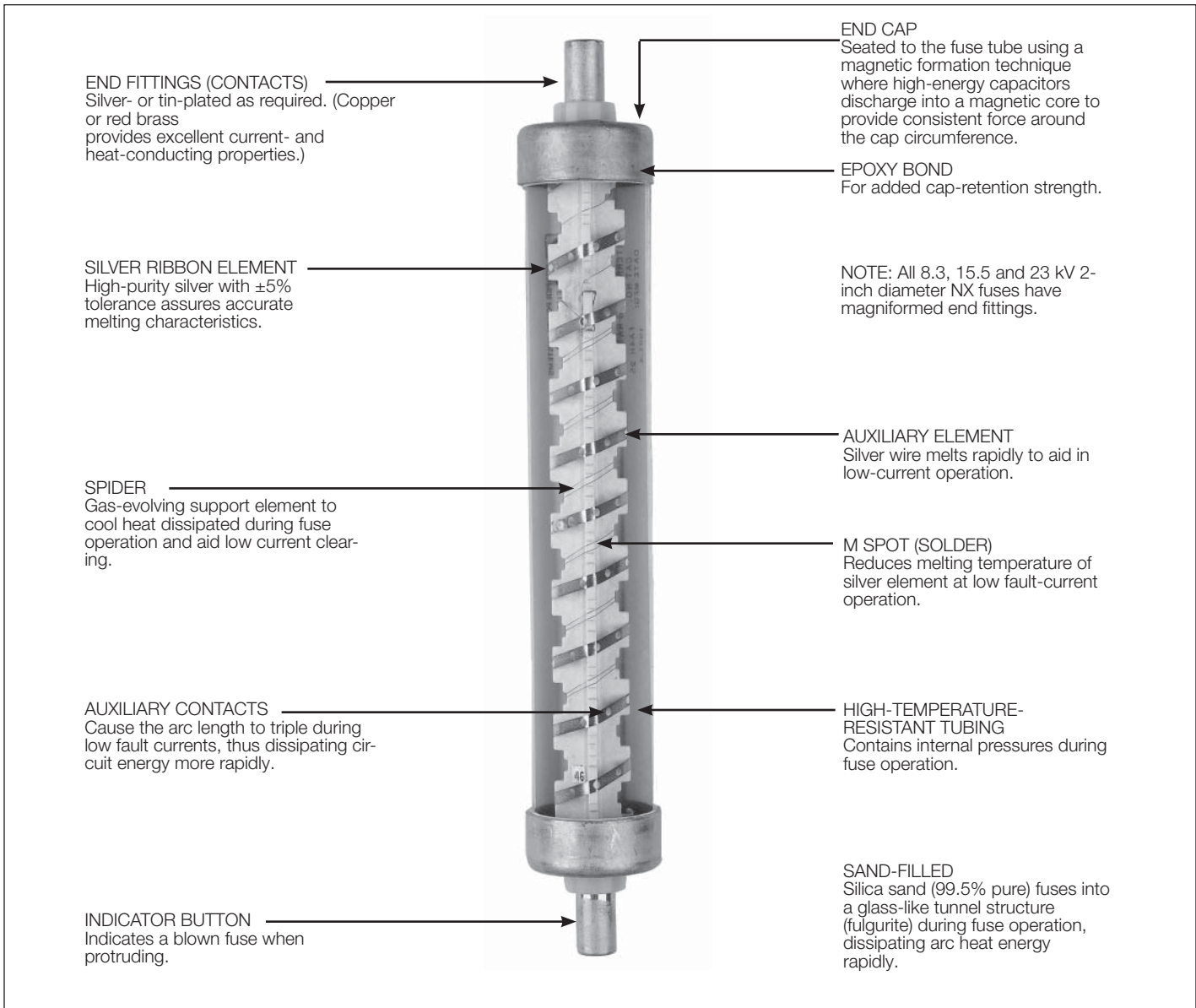

Figure 4.
Basic components of the McGraw-Edison NX current-limiting fuse.

TABLE 3
Electrical Ratings

Continu- ous Current Rating (A)	Maximum Design Voltage													
	4.3 kV		5.5 kV		8.3 kV		15.5 kV		23 kV		27 kV		38 kV	
	Min. Melt I ² t (A ² S)x10 ³	Max. Let through I ² t (A ² S)x10 ³	Min. Melt I ² t (A ² S)x10 ³	Max. Let through I ² t (A ² S)x10 ³	Min. Melt I ² t (A ² S)x10 ³	Max. Let through I ² t (A ² S)x10 ³	Min. Melt I ² t (A ² S)x10 ³	Max. Let through I ² t (A ² S)x10 ³	Min. Melt I ² t (A ² S)x10 ³	Max. Let through I ² t (A ² S)x10 ³	Min. Melt I ² t (A ² S)x10 ³	Max. Let through I ² t (A ² S)x10 ³	Min. Melt I ² t (A ² S)x10 ³	Max. Let through I ² t (A ² S)x10 ³
1.5	-	-	-	-	0.01	0.15	0.01	0.15	-	-	-	-	-	-
2.9	-	-	-	-	-	-	-	-	-	-	-	-	-	-
3	-	-	-	-	0.05	0.30	0.05	0.59	-	-	-	-	-	-
4.5	-	-	-	-	0.05	0.30	0.05	0.59	-	-	-	-	-	-
6	-	-	0.13	0.60	0.13	0.76	0.13	1.44	0.13	1.8	0.08	1.6	0.08	3.5
8	-	-	0.35	1.05	0.34	1.5	0.21	2.90	0.21	3.5	0.21	2.5	0.21	4.7
10	-	-	0.52	2.0	0.52	3.6	0.52	6.65	0.52	7.8	0.53	3.8	0.53	5.6
12	-	-	1.15	4.0	1.15	6.3	1.15	10.4	1.15	13.5	0.72	6.0	0.73	9.0
15	-	-	-	-	-	-	-	-	-	-	0.74	6.0	0.74	10.5
18	1.5	7.9	1.25	10.0	1.25	11.0	1.25	10.5	1.25	16.2	1.30	7.0	1.15	10.5
20	-	-	1.65	14.0	1.65	13.0	1.65	16.5	1.65	18.0	1.65	9.4	1.65	13.8
25	2.9	12.5	3.0	38.0	2.0	24.0	2.0	27.0	2.0	28.0	2.95	16.0	3.00	19.5
30	-	-	3.0	46.0	4.0	31.0	4.0	34.0	4.0	36.0	4.60	26.0	4.60	29.0
35	2.9	25.0	-	-	-	-	-	-	-	-	-	-	-	-
40	-	-	5.3	67.0	8.0	50.0	8.0	57.0	8.0	62.0	5.25	29.5	5.13	35.00
45	6.6	69.0	-	-	-	-	-	-	-	-	-	-	-	-
50	9.0	75.0	9.0	98.0	11.6	72.0	11.6	90.0	-	-	11.30	65.0	11.60	80.00
60*	-	-	-	-	15.8	125.0	16.0	132.0	-	-	18.40	104.0	18.50	117.0
65	18.2	100.0	18.2	167.0	26.5	130.0	26.5	200.0	-	-	-	-	-	-
75	26.5	150.0	26.5	244.0	-	-	-	-	-	-	-	-	-	-
80	-	-	-	-	47.0	220.0	46.5	340.0	-	-	-	-	-	-
80*	-	-	-	-	32.5	200.0	32.5	225.0	-	-	20.10	118.0	21.20	140.0
100	45.5	240.0	-	-	100.0	450.0	100.0	580.0	-	-	-	-	-	-
100*	-	-	36.0	380.0	-	-	47.0	370.0	-	-	26.00	260.0	47.00	320.0
125	-	-	-	-	-	-	-	-	-	-	-	-	-	-
125*	-	-	-	-	-	-	-	-	-	-	-	-	-	-
130*	73.0	400.0	73.0	790.0	102.0	520.0	102.0	790.0	-	-	-	-	-	-
140	-	-	-	-	-	-	-	-	-	-	-	-	-	-
150*	106.0	620.0	105.0	980.0	-	-	-	-	-	-	-	-	-	-
160*	-	-	-	-	187.0	800.0	187.0	1380.0	-	-	-	-	-	-
200*	185.0	960.0	-	-	400.0	1800.0	400.0	2350.0	-	-	-	-	-	-

*Indicates two smaller fuses in parallel.

TABLE 4
NX Clip-Style Fuse Dimensional Information (See Figure 5 for Dimensional Drawing)

Fuse Description	Mounting Code Number*	Dimensions - inches (mm)		
		A	B	C
1 1/8" diameter fuse for clip mounting	4	10.0 (254)	1.13 (28.6)	1.00 (25)
2" diameter fuse for clip mounting	4	10.0 (254)	2.00 (51)	1.00 (25)
	5	14.31 (363)	2.00 (51)	1.00 (25)
	6	17.13 (435)	2.00 (51)	1.00 (25)
3 7/16" diameter fuse for clip mounting	5	14.69 (373)	3.44 (87)	1.19 (30)
	6	17.5 (445)	3.44 (87)	1.19 (30)
	9	27.38 (695)	3.44 (87)	1.19 (30)
	10	35.38 (899)	3.44 (87)	1.19 (30)

*Code number of mounting must match code number of fuse.

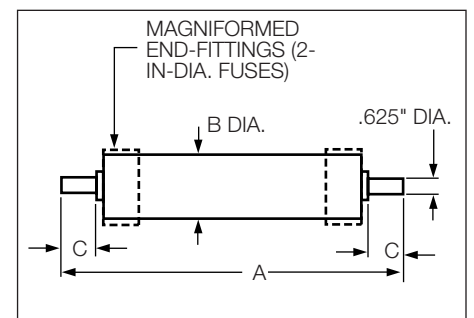

Figure 5.
NX clip style dimensional drawing. (See Table 4 for dimensions.)

TABLE 5
NX Hinge-Style Switchblade Electrical Ratings and Dimensional Information (See Figure 6 for Dimensional Drawing)

Electrical Ratings		Description	Mounting Code Number*	Dimension A in. (mm)
Voltage (kV)	Continuous and Loadbreak Current (A)			
8.3	200	Blade	1	14 (356)
15.5	200	Short 15 kV blade	1	14 (356)
15.5	200	Long 15 kV blade	2	18.5 (470)

*Code number of mounting must match code number of switchblade.

TABLE 6
NX Hinge-Style Fuse Dimensional Information (See Figures 7 and 8 for Dimensional Drawing)

Fuse Description	Voltage Rating (kV)	Mounting Code Number*	Dimensions - inches (mm)				
			A	B	C	D	R
1 1/8" diameter hinged fuse**	4.3, 5.5, and 8.3	1	14.0 (356)	8.88 (226)	1.38 (35)	0.38 (10)	13.31 (338)
	15.5	2	18.5 (470)	8.88 (226)	1.38 (35)	0.38 (10)	17.81 (452)
2" diameter hinged fuse***	4.3, 5.5, and 8.3	1	13.75 (349)	8.94 (227)	2.44 (62)	1.44 (37)	13.31 (338)
	15.5	2	18.25 (463)	8.94 (227)	2.44 (62)	1.44 (37)	17.81 (452)

* Code number of mounting must match code number of fuse.

** See Figure 11 for dimensional drawing.

*** See Figure 12 for dimensional drawing.

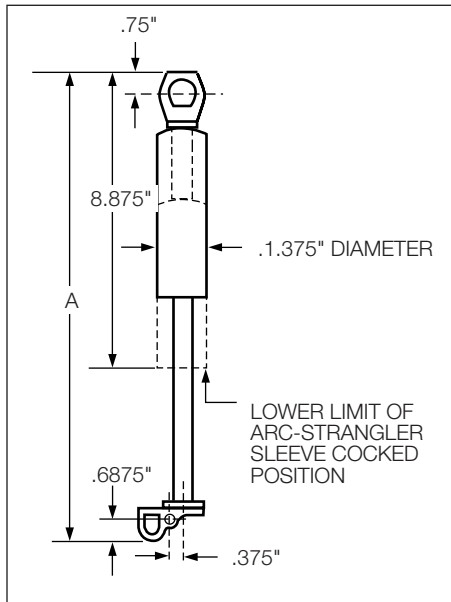

Figure 6.
NX hinge-style switchblade with Arc-Strangler loadbreaking device. (See Table 5 for dimensions.)

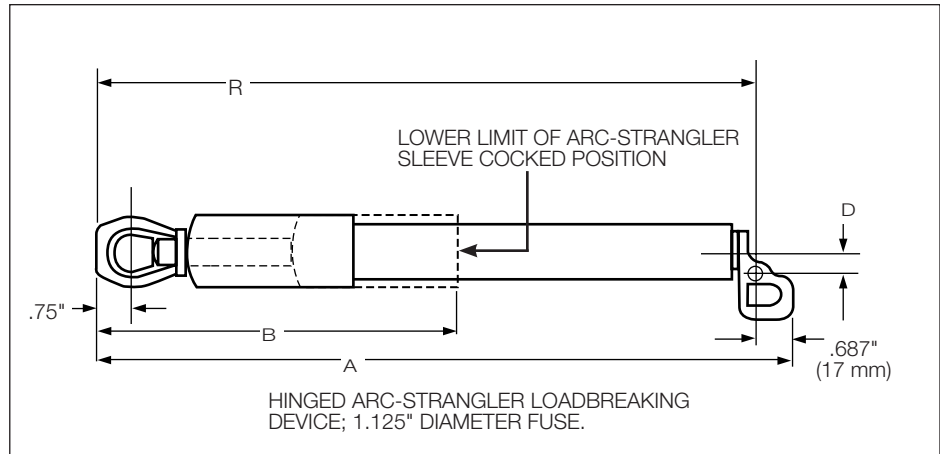

Figure 7.
NX hinge-style (1.125" dia.) fuse dimensional drawing.

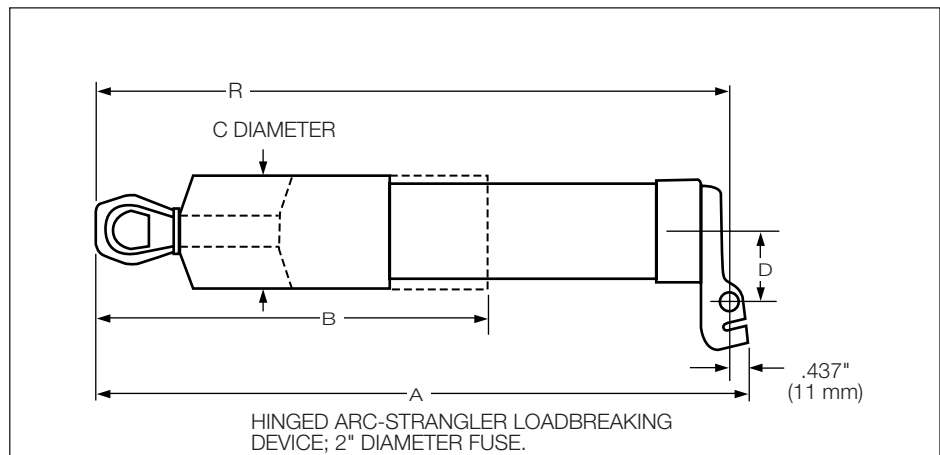

Figure 8.
NX hinge-style (2" dia.) fuse dimensional drawing.

Protective Characteristics

LET-THROUGH CURRENTS

Type NX fuses have the ability to limit system fault currents, frequently to a fraction of system fault capability. This greatly reduced value is referred to as let-through current.

The operating advantages, along with fast clearing, include greatly reduced burning at the point of fault and minimal line damage. In addition, there is less chance of damage, both electrical and mechanical (by magnetic forces), to other equipment in the faulted circuit. Figures 9, 10, and 11 show maximum let-through current values.

The maximum let-through curves provide an indication of the amount of current-limiting action provided by NX fuses: Assume an 8.3 kV circuit has a 20,000 rms A fault current available. Extend a line upward on the curve in Figure 10 and note that there would be an unlimited maximum fault current of 48,000 peak amperes. Protecting this circuit with a 40 A NX fuse allows a maximum let-through current of 7800 peak amperes. This is equivalent to an unprotected circuit having a maximum fault available of 3200 rms A.

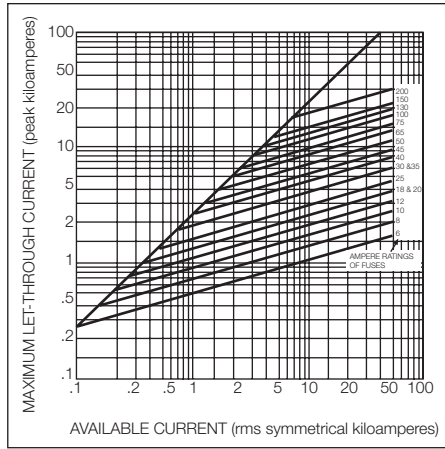

Figure 9.
Maximum let-through current for NX current-limiting fuses – 4.3 and 5.5 kV.

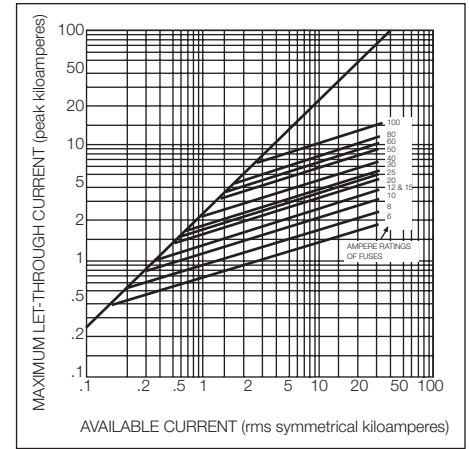

Figure 11.
Maximum let-through current for NX current-limiting fuses – 27 and 38 kV.

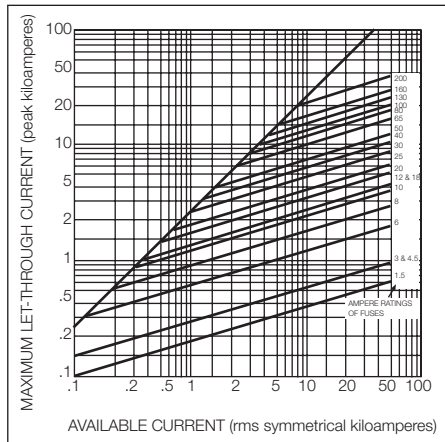

Figure 10.
Maximum let-through current for NX current-limiting fuses – 8.3, 15.5 and 23 kV.

APPLICATION

Voltage Rating Selection

To determine the correct voltage rating for a current-limiting fuse, proper consideration must be given to the type of distribution system, the system voltage, the transformer winding connection, and neutral grounding. In general, single-phase fusing permits the use of a fuse with phase-to-neutral voltage rating; whereas, three-phase fusing usually requires a fuse with phase-to phase voltage rating. However, where it is desirable (because of economics, standardization, oil space, etc.), NX fuses with phase-to-neutral voltage ratings may be used on three-phase applications provided certain parameters are met. See "Three-Phase Applications". Allowance is normally given for voltages slightly exceeding the normal system voltage. (Standards consider the maximum service voltage as 5 to 6% over normal.) Since each current-limiting fuse has a maximum design voltage, application must be such that the post-interruption voltage impressed across the fuse does not exceed that maximum design voltage.

Table 7 lists the recommended voltage ratings for current-limiting fuses applied on the most commonly encountered distribution systems.

AMPERE RATING SELECTION

Another consideration in the selection of a current-limiting fuse is the ampere rating. The rating must be such that the inrush currents that can occur in a transformer will not cause the fuse to operate.

Two rules of thumb should be used for this consideration:

1. A fuse should be able to withstand 12 times the transformer-rated current for 0.1-second without element damage.
2. The element must be able to withstand 25 times the transformer-rated current for one-half cycle.

This second rule was established because of the magnitude of the first loop of inrush current which can far exceed 12 times the transformer rated current and thus cause element damage and the steep slope in the melting characteristics of the current-limiting fuse. Because TCC curves only extend down to the 0.01-second melt time, it is satisfactory to compare the 25 times rated current to the 0.01-second minimum melt of a fuse. This will provide only a slightly more conservative comparison than using

TABLE 7
Recommended Current-Limiting Fuse Voltage Ratings

System Voltage (kV)		Recommended NX Fuse Rating (kV)			
Nominal	Maximum	Four-Wire Multi-Grounded Neutral		Delta	
		Single-Phase	Three-Phase	Single-Phase	Three-Phase
2.4 2.4/4.16	2.54 2.54/4.4	— 4.3	— 5.5*	4.3 —	4.3 —
4.16 4.8 4.8/8.32	4.4 5.1 5.1 /8.8	— — 5.5	— — 8.3*	4.3 5.5 —	4.3 5.5 —
6.9 6.93/12	7.26 73/12.7	— 8.3	— 15.5*	8.3 —	8.3 —
7.2 7.2/12.47 7.97 7.97/13.8	7.62 7.62/13.2 8.4 8.4/14.5	— 8.3 — 8.3	— 15.5* — 15.5*	8.3 — 8.3 —	8.3 — 8.3 —
8.32 8.32/14.4	8.8 8.8/15.2	— 8.3	— 15.5*	8.3 —	8.3 —
12/20.8 12.47	12.7/22 13.2	15.5 —	23* —	— 15.5	— 15.5
13.2/22.9 13.2	14/24.2 14.5	15.5 —	23* —	— 15.5	— 15.5
14.4/24.9 14.4	15.2/26.4 15.2	15.5 —	27* —	— 15.5	— 15.5
19.9/34.5 34.5	21.1/36.5 36.5	23 —	38* —	— 38	— 38

*A line-to-neutral rating may be used if certain parameters are met.

the 0.0083-second value. Although, theoretically, higher values of inrush current are possible, test data and field experience indicate that they are quite unlikely to exceed this value.

The second consideration for selecting the fuse ampere rating is the maximum load current that the fuse is expected to carry without fuse damage. This includes the allowable transformer overloading for certain periods of time. Transformer fusing tables normally list the ranges of overload provided. If the long-time minimum-melt current is known for the fuse size in question, it can be compared to the transformer-rated current to determine the exact percentage of overload permitted. Since fuse heating plus transformer heating would probably raise the ambient temperature for the fuse, the long-time minimum-melt current should be reduced accordingly. An ambient of 40°C is often assumed for this condition. Of course, the proposed current-limiting fuse must be capable of carrying such currents without damage, and it must interrupt minimum-melt currents and all higher values.

Transformer primary fuses are not usually applied to coordinate with the ANSI transformer safe-loading requirement; namely, melting at 300% kVA rating in 5 minutes and sensing 200% kVA in about 30 minutes. This duty would require a fuse size that would be subject to inrush-current damage. In addition, it would respond too rapidly to short-time, high overloads. Common practice is to fuse to interrupt overload currents in the 200 to 300% range after several hours' duration. Specification recommendations are shown in Tables 8 and 9.

TABLE 8
Overload Protection of Oil-Insulated – Self-Cooled, and Dry-Type Transformers¹ (Single-Phase Application)

Transformer (kVA)	Nominal Single-Phase Voltage Across Transformer Terminals (kV)																							
	2.4		4.16				4.8		7.2-7.96				12-12.47				13.2-14.4		19.9		24.9		34.5	
	Recommended Fuse Voltage (kV)																							
	4.3		4.3		5.5		5.5		8.3		15.5		15.5		23		27		38					
Recommended Fuse-Current Ratings (amperes) ^{2, 5}																								
Column A – 140-200% Transformer Rating																								
Column B – 200-300% Transformer Rating																								
A	B	A	B	A	B	A	B	A	B	A	B	A	B	A	B	A	B	A	B	A	B			
1.5		18 ³		18 ³		6 ³		6 ³		1.5 ³		1.5 ³		1.5 ³		6 ³		6 ³		6 ³				
3		18 ³		18 ³		6 ³		6 ³		1.5 ³		1.5 ³		1.5 ³		6 ³		6 ³		6 ³				
5		18 ³		18 ³		6 ³		6 ³		1.5 ³		1.5 ³		1.5 ³		6 ³		6 ³		6 ³				
7.5		18 ³		18 ³		6 ³		6 ³		1.5 ³		1.5 ³		1.5 ³		6 ³		6 ³		6 ³				
10		18 ³		18 ³		6 ³		6 ³		3 ³		1.5		1.5 ³		6 ³		6 ³		6 ³				
15		18 ³		18 ³		6		6		3		3		1.5		6 ³		6 ³		6 ³				
25		18		18 ³		10		8		6		3		3		6 ³		6 ³		6 ³				
37.5		25		18 ³		18		12		10		6		6		6 ³		6 ³		6 ³				
50	25	45	18	25		20		18		12		8		6		6 ³		6 ³		6 ³				
75	45	75	25	35	25	30		25		18		10		10		8		6		6 ³				
100	50	100	35	50	30	50	25	40		25		12		12		10		8		6				
150	100	150	45	100	50	75	40	65	25	40	18	25	18	20		12		10		8				
167	100	150	50	100	50	75	50	75	30	50	20	30	18	25	12	18		12		10				
200	130	200	65	130	75	100	50	75	30	65	25	40	20	30	12	20	12	15		12				
250	150	200	75	150	75	130	65	100	40	80	30	50	25	40	18	25	15	20		12				
333	200		130	200	100	150	100	150	65	100	30	65	30	50	25	40	20	30		15				
500			150		150		130		100	160	50	100	50	80	30		30	50	20	30				
750			200 ⁴						130	200	80	130	80	130	40 ⁴		40	60	30	50				
1000									200		100	200	100	160			60	100	40	60				
1250									200 ⁴		130	200	130	160			80	100	50	80				
1500											200		160				80		60	100				
1667											200		160				100		60	100				
2000											200		160 ⁴				100 ⁴		80	100				
2500																			100					
3000																			100 ⁴					

Notes:

1. Recommendations are based on fuse-melting characteristics at an ambient temperature of 40°C (See R240-60-2).
2. To prevent fuse blowing on transformer inrush, DO NOT USE FUSES SMALLER THAN RECOMMENDED without specific approval of the manufacturer.
3. Fuses allow in excess of 300% of load.
4. Fuses allow less than 140% of load.
5. Ratings in shaded area are for parallel-fuse combinations.

TABLE 9
Overload Protection of Oil-Insulated – Self-Cooled, and Dry-Type Transformers¹ (Three-Phase Application)

Transformer (kVA)	Nominal Three-Phase Voltage Across Transformer Terminals																					
	2.4		4.16				4.8		7.2-7.96		8.32		12.47		13.2-14.4		20.8		22.9-24.9		34.5	
	Recommended Fuse Voltage (kV)																					
	4.3		4.3		5.5		5.5		8.3		15.5		15.5		15.5		23		27		38	
Recommended Fuse-Current Ratings (amperes) 2, 5 Column A–140-200% Transformer Rating Column B–200-300% Transformer Rating																						
	A	B	A	B	A	B	A	B	A	B	A	B	A	B	A	B	A	B	A	B	A	B
15		18 ³		18 ³		6 ³		6 ³		1.5		1.5		1.5		1.5		6 ³		6 ³		6 ³
22.5		18 ³		18 ³		6 ³		6 ³		3		3		1.5		1.5		6 ³		6 ³		6 ³
30		18 ³		18 ³		8		6		4.5		4.5		3		3		6 ³		6 ³		6 ³
45		18		18 ³		10		10		6		6		3		3		6 ³		6 ³		6 ³
75	25	35		18	12	20	12	18		10		10		6		6		6 ³		6 ³		6 ³
100	35	50		25	20	25	18	25	12	18		12		10		8		6		6 ³		6 ³
112.5	45	65		25	25	30	18	30	12	18		12		10		10		6		6		6 ³
150	50	100	25	45	25	40	25	40	18	25		18		12		12		8		8		6 ³
200	65	100	45	65	40	65	30	50	20	30	18	25		18	12	18		10		10		6 ³
225	75	130	45	75	40	75	40	65	25	40	20	30		18	12	20		10		10		8
300	100	200	50	100	50	75	50	75	30	50	25	50	20	25	18	25		12		12		10
500	200		100	150	100	150	75	130	50	100	50	80	30	50	30	50	20	25	18	25		15
750	200 ⁴		130	200	130		130		80	130	65	130	40	80	40	80	25	40	25	40	18	25
1000			200		150 ⁴		150		100	160	100	160	65	100	65	100	30		30	50	25	30
1500									160	200	130	200	100	160	80	160	40 ⁴		50	80	30	50
2000									200		200		130	200	130	160			60	100	40	60
2500											200 ⁴		160	200	160				80		50	100
3000													200		160				100		60	100
3500													200		160 ⁴				100 ⁴		80	100
3750													200 ⁴						100 ⁴		80	
4000													200 ⁴								80	
5000																					100	

- Notes:
1. Recommendations are based on fuse-melting characteristics at an ambient temperature of 40°C (See R240-60-2).
 2. To prevent fuse blowing on transformer inrush, DO NOT USE FUSES SMALLER THAN RECOMMENDED without specific approval of the manufacturer.
 3. Fuses allow in excess of 300% of load.
 4. Fuses allow less than 140% of load.
 5. Ratings in shaded area are for parallel-fuse combinations.

Derating NX Fuses – Raised Ambient Temperatures

To determine the proper NX fuse size for carrying desired current and percent overload available at raised ambient temperatures, the minimum-melt current must be derated. The curves in Figure 12 show the derating factors for NX fuse applications at raised ambient temperatures in air, in canisters suspended in oil, and in transformer bushings. (These curves are based on a six-hour melting time, not the maximum pre-melt current.)

By using these curves in conjunction with minimum-melt current values from the minimum-melting characteristic table for NX fuses, Table 10, which is based on a 25° C ambient temperature and a six-hour melting time, the proper fuse size can be determined.

Example

To derate the minimum-melt current of a 5.5 kV, 20 A NX fuse mounted in free air at a raised ambient temperature of 75° C:

1. On Figure 12, draw a vertical line at 75° C to intersect the free-air curve.
2. From the intersection point, draw a horizontal line to the vertical axis to determine the derating factor which, in this case, is 80%.
3. From Table 10, find the minimum-melt current for the 5.5 kV, 20 A fuse which, in this case, is 28 A.
4. Multiply this value by the derating factor to determine the derated minimum-melt current: 28 A x .80 = 27 A.

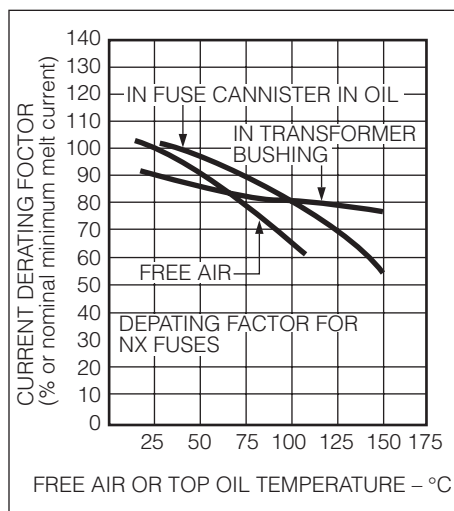

Figure 12. Derating curves for NX fuse application at raised ambient temperatures.

ORDERING INFORMATION

To order a Cooper Power Systems Clip-style mounting NX fuse and the hinge-style fuse, first determine the voltage rating (Table 7) and amperage ratings of the fuse(s) (Table 8 & Table 9) device, and then select the appropriate catalog number from Table 11 or 12. For parallel fusing, order two fuses.

To order an NX hinge-style switchblade, choose the appropriate catalog number from Table 13.

TABLE 10 Minimum-Melting Characteristic for NX Current-Limiting Fuses Based on a 25° C Ambient Temperature and a Six-Hour Melting Time

Voltage Rating (kV)	Continuous Current Rating (amp)	Minimum Melt Current (Amp)
4.3	18	27
	25	37
	35	50
	45	64
	50	68
	65	78
	75	90
	100	110
	130*	156
	150*	180
200*	220	
5.5	6	9
	8	12
	10	14
	12	17
	18	27
	20	28
	25	37
	30	42
	40	55
	50	68
	65	78
	75	90
	100*	136
	130*	156
150*	180	
8.3	1.5	2.3
	3	4.5
	4.5	6.7
	6	9
	8	12
	10	14
	12	17
	18	26
	20	28
	25	35
30	41	
40	52	
50	63	
50*	70	
60*	82	
65	80	
80	96	
80*	104	
100	120	
100*	126	
130*	160	
160*	192	
200*	240	
15.5	1.5	2.3
	3	4.5
	4.5	6.7
	6	9
	8	12
	10	15
	12	18
	18	26
	20	28
	25	35
30	41	
40	52	
50	63	
50*	70	
60*	82	
65	80	
80	96	
80*	104	
100	120	
100*	126	
130*	160	
160*	192	
200*	240	
23	6	9
	8	12
	10	15
	12	18
	18	26
	20	28
	25	35
30	41	
40	52	
27 and 38	6	9
	8	12
	10	15
	12	18
	15	22
	18	26
	20	28
	25	35
	30	41
	40	52
	50	63
	60*	82
	80*	104
100*	126	

TABLE 11
NX Clip-Style Current-Limiting Fuse (Refer to Figure 5)

Voltage (kV)	Rating*		Mounting Code Number	Fuse Diameter (in.)†	Catalog Number
	Continuous Current (A)				
4.3	18	4	4	1.125	FA1H18
	25	4	4	1.125	FA1H25
	35	4	4	1.125	FA1H35
	45	4	4	2	FA1H45
	50	4	4	2	FA1H50
	65	4	4	2	FA1H60
	75	4	4	2	FA1H75
	105	4	4	2	FA1H100
5.5	6	4	4	1.125	FA2H6
	8	4	4	1.125	FA2H8
	10	4	4	1.125	FA2H10
	12	4	4	1.125	FA2H12
	18	4	4	1.125	FA2H18
	20	4	4	2	FA2H20
	25	4	4	2	FA2H25
	30	4	4	2	FA2H30
	40	4	4	2	FA2H40
	50	4	4	2	FA2H50
	65	4	4	2	FA2H65
75	4	4	2	FA2H75	
8.3	1.5	4	4	1.125	FA3H1
	3	4	4	1.125	FA3H3
	4.5	4	4	1.125	FA3H4
	6	4	4	1.125	FA3H6
	8	4	4	1.125	FA3H8
	10	4	4	1.125	FA3H10
	12	4	4	1.125	FA3H12
	18	4	4	2	FA3H18
	20	4	4	2	FA3H20
	25	4	4	2	FA3H25
	30	4	4	2	FA3H30
	40	4	4	2	FA3H40
	50	5	5	3.438	FA3H50
	65	5	5	3.438	FA3H65
80	5	5	3.438	FA3H80	
100	5	5	3.438	FA3H100	
15.5	1.5	5	5	1.125	FA4H1
	3	5	5	1.125	FA4H3
	4.5	5	5	1.125	FA4H4
	6	5	5	2	FA4H6
	8	5	5	2	FA4H8
	10	5	5	2	FA4H10
	12	5	5	2	FA4H12
	18	5	5	2	FA4H18
	20	5	5	2	FA4H20
	25	5	5	2	FA4H25
	30	5	5	2	FA4H30
	40	5	5	2	FA4H40
	50	6	6	3.438	FA4H50
	65	6	6	3.438	FA4H65
80	6	6	3.438	FA4H80	
100	6	6	3.438	FA4H100†	
23	6	6	6	2	FA5H6
	8	6	6	2	FA5H8
	10	6	6	2	FA5H10
	12	6	6	2	FA5H12
	18	6	6	2	FA5H18
	20	6	6	2	FA5H20
	25	6	6	2	FA5H25
	30	6	6	2	FA5H30
40	6	6	2	FA5H40	
27	6	9	9	3.438	FA9H6
	8	9	9	3.438	FA9H8
	10	9	9	3.438	FA9H10
	12	9	9	3.438	FA9H12
	15	9	9	3.188	FA9H15
	18	9	9	3.438	FA9H18
	20	9	9	3.438	FA9H20
	25	9	9	3.438	FA9H25
	30	9	9	3.438	FA9H30
40	9	9	3.438	FA9H40	
50	9	9	3.438	FA9H50	
38	6	10	10	3.438	FA10H6
	8	10	10	3.438	FA10H8
	10	10	10	3.438	FA10H10
	12	10	10	3.438	FA10H12
	18	10	10	3.438	FA10H18
	20	10	10	3.438	FA10H20
	25	10	10	3.438	FA10H25
30	10	10	3.438	FA10H30	
40	10	10	3.438	FA10H40	
50	10	10	3.438	FA10H50	

* 4.3, 5.5, 8.3, 15.5, 23 kV have 50,000 A symmetrical rating, 27 and 38 kV have 35,000 A symmetrical rating.

** Code number of mounting must match code number of fuse or switchblade.

† All 2" diameter fuses have magnifomed end fittings.

TABLE 12
NX Hinge-Style Current-Limiting Fuses (with Arc-Strangler Loadbreaking Device)
 (Refer to Figures 7 & 8)

Rating		Mounting Code Number*	Fuse Diameter (in.)**	Catalog Number
Voltage (kV)	Continuous Current (A)			
For Single- and Parallel-Unit Hinge-Style Mountings				
4.3	18	1	1.125	FA1A18
	25	1	1.125	FA1A25
	35	1	1.125	FA1A35
	45	1	2	FA1A45
	50	1	2	FA1A50
	65	1	2	FA1A65
	75	1	2	FA1A75
5.5	100	1	2	FA1A100
	6	1	1.125	FA2A6
	8	1	1.125	FA2A8
	10	1	1.125	FA2A10
	12	1	1.125	FA2A12
	18	1	1.125	FA2A18
	20	1	2	FA2A20
	25	1	2	FA2A25
	30	1	2	FA2A30
	40	1	2	FA2A40
	50	1	2	FA2A50
8.3	65	1	2	FA2A65
	75	1	2	FA2A75
	1.5	1	1.125	FA3A1
	3	1	1.125	FA3A3
	4.5	1	1.125	FA3A4
	6	1	1.125	FA3A6
	8	1	1.125	FA3A8
	10	1	1.125	FA3A10
	12	1	1.125	FA3A12
	18	1	2	FA3A18
	20	1	2	FA3A20
15.5	25	1	2	FA3A25
	30	1	2	FA3A30
	40	1	2	FA3A40
	1.5	2	1.125	FA4A1
	3	2	1.125	FA4A3
	4.5	2	1.125	FA4A4
	6	2	2	FA4A6
	8	2	2	FA4A8
	10	2	2	FA4A10
	12	2	2	FA4A12
	18	2	2	FA4A18
20	2	2	FA4A20	
25	2	2	FA4A25	
30	2	2	FA4A30	
40	2	2	FA4A40	

* Code number of mounting must match code number of fuse or switchblade.

** All 2" diameter fuses have magniformed end fittings with stamped hinge.

ADDITIONAL LITERATURE

Cooper Power Systems has additional reference information available on NX fuses. For copies of any of the following bulletins, contact your local Cooper Power Systems representative.

- R240-60-2 NX Current-Limiting Fuses –Minimum Melting Characteristics
- R240-60-3 Coordination of NX Fuses With EEI-NEMA Fuse Links
- R240-60-5 Maximum Total and Minimum Melt Comparison of NX Fuses
- R240-60-6 Mounting Clearances – Type NX Fuses
- R240-60-7 Parallel Operation of NX Fuses
- R240-60-8 A Guide to Secondary Cable Fault Clearing With NX Fuses
- R240-60-9 Properties of Molded Box for NX Fuses With Arc-Strangler Switch
- R240-60-11 Specifications–NX Fuses With Arc-Strangler Switch
- R240-60-13 NX Fuse Recommended Transformer Applications

TABLE 13
NX Hinge-Style Switchblades (with Arc-Strangler Loadbreaking Devices) (Refer to Figure 6)

Rating		Description	Mounting Code Number*	Catalog Number
Voltage (kV)	Continuous and Loadbreak Current (A)			
8.3	200	Blade	1	FA1B1
15.5	200	Short 15 kV blade	1	FA4B1
15.5	200	Long 15 kV blade	2	FA3B1

* Code number of mounting must match code number of fuse or switchblade.



© 2007 Cooper Power Systems, Inc., or its affiliates.
McGraw-Edison, NX and Arc-Strangler are valuable trademarks of Cooper
Industries in the U.S. and other countries. You are not permitted to use the Cooper
Trademarks without the prior written consent of Cooper Industries, Inc.

1045 Hickory Street
Pewaukee, WI 53072
www.cooperpower.com
