

Cutouts and Fuse Links

Electrical Apparatus

327-30

UltraSIL Polymer-Insulated and Porcelain Type L Open Distribution Cutout

DESCRIPTION

Cooper Power Systems has set a new standard of excellence for polymer distribution cutouts with the introduction of UltraSIL polymer-insulated interchangeable cutouts. Our premium UltraSIL polymer-insulated cutout incorporates an industry recognized silicone rubber insulating material with superior hydrophobic qualities. Cooper Power Systems offers Type L cutouts in both polymer and porcelain designs, which provide reliable overcurrent protection for primary distribution circuits. Overcurrent protection safeguards an electric system from excessive currents produced by abnormal conditions such as faults, line or equipment overloads, or equipment failures. Polymer and porcelain Type L cutouts are ruggedly constructed and will provide full range overcurrent protection from minimum melt of a given fuse link to the maximum nameplate interrupting current rating of the cutout.

Polymer and porcelain Type L cutouts are available in 15.5 kV and 27 kV voltage ratings. Both polymer and porcelain Type L cutouts are available with a 100 A or 200 A fuse holder or with a 300 A disconnect blade.

INTERCHANGEABILITY

The key for both polymer and porcelain Type L cutout designs is fuseholder interchangeability. Polymer and porcelain Type L cutouts eliminate the need to stock fuse holders from each manufacturer and are designed to be fuseholder interchangeable with polymer and porcelain cutouts manufactured by S & C Electric Co. (Type XS), A.B. Chance Co. (Type C) and ABB (Type ICX).

Fuseholder interchangeability reduces the time required to re-fuse a cutout during an outage by eliminating the need to determine which manufacturer's cutout is on the pole. Re-fusing of the spare fuseholder can be done even before the lineman leaves the truck. Interchangeability also significantly reduces inventory.

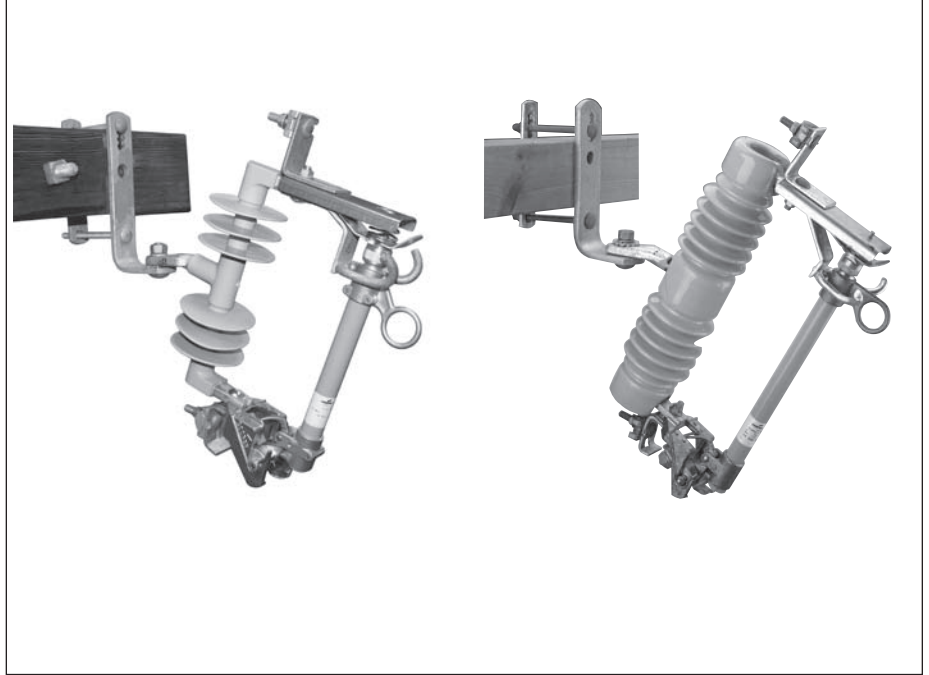

Figure 1. UltraSIL Polymer-Insulated and Porcelain Type L Open Distribution Cutout with 100 A fuseholder.

DESIGN FEATURES

The backbone of the UltraSIL polymer-insulated Type L cutout is comprised of an E-glass fiberglass rod with crimped-on galvanized steel hanger and end fittings. The crimping process results in a robust design capable of withstanding numerous opening and closing operations and the severe forces present during fault current interruptions. The frame is over molded with the industry leading, track resistant, UltraSIL silicone rubber polymer-housing. Independent laboratory tests have verified the superiority of silicone rubber in terms of resistance to UV degradation, surface tracking/performance in contaminated environments and other important insulating properties. The complete cutout assembly works together as a system and will stand up to years of exposure to environmental extremes.

The porcelain Type L cutout is designed with a solid core, birdproof, one piece porcelain frame with uniform shed configuration. Sulfur

cemented studs provide high strength connections. An extra creepage unit is available for high contaminating environments

The fuseholder is constructed of an epoxy impregnated glass filament wound tube over an arc-quenching inner liner material. A large bronze cast pull ring is utilized for ease of installation and re-fusing. The bronze trunnion, with lifting ring having both front and side accessibility, is silver plated for minimum contact resistance. The grooved flipper assembly controls link tension, assures low fault current interruption and prevents link breakage on "close-in."

The cast bronze lower hinge assembly has deep pockets for the trunnion to pivot to minimize accidental fuse removal. The rugged design with wide opening means easy fuseholder installation and removal. The lower contact assembly utilizes stainless steel backup springs and silver-to-silver contacts to minimize contact resistance and assure excellent

continuous contact throughout the life of the cutout. The contacts are designed to carry 300 A continuous. Silver-to-silver top contacts are again used to minimize contact resistance. Type L design develops high contact pressure to assure excellent contact for operating currents and until fault interruption is completed.

Loadbreak hooks, for use with a loadbreak tool, are standard and serve as a "close-in" guide to assure positive make.

Lubricant is applied to all separable connector interchanges. All hardware is designed to interlock during assembly to assure correct alignment. The rugged design assures smooth operation and long life.

APPLICATION

Proper cutout application requires several major system considerations: system operating voltage, insulation level, type of system grounding, maximum available fault current the cutout may be subjected to and anticipated maximum continuous load current.

The polymer and porcelain Type L cutout voltage rating is the maximum design voltage of the cutout. It can be applied, without restrictions, on any three-phase system that has system line-to-line voltage less than or equal to the cutout rating. Type L cutouts can also be applied on single-phase or three-phase solidly grounded wye connected circuits. The circuit must have line-to-neutral voltages up to the voltage rating of the cutout as long as the maximum recovery voltage does not exceed the cutout's rating.

The Basic Impulse Insulation Level (BIL) of a cutout should be coordinated with the insulation of other connected apparatus. The interrupting rating of a cutout should be greater than or equal to the maximum available system fault current unless used in conjunction with current-limiting fuses such as the Companion II backup fuse or the ELF full-range fuse. The cutout selected should have a continuous current rating sufficient to handle the expected load. The 100 A rated fuseholder accepts fuse links from a fraction of 1 A to 100 A. The 200 A fuseholder will accept fuse links with ratings above 100 A to 200 A.

For areas with a high probability of lightning, a Dual Element Link (D-Link) from Cooper Power Systems can be used in the Type L open cutout. The cutout-mounted

D-Link provides a high surge withstand capability which reduces the probability of damage to the link as a result of lightning surges, and thus reduces nuisance fuse blowing. These D-Link characteristics make it possible to place the primary arrester on the transformer tank, eliminating excess lead lengths, thus, providing the best surge protection possible to the transformer. Refer to catalog section K-SEC 100 for ordering information about the D-link, and other Cooper Power Systems fuse links as well as catalog section 327-40 for all Kearney links.

When selecting a cutout or fuse, it is important to consider future load growth and other planned system expansion.

Cooper Power Systems offers full-range current-limiting fuses for applications where system fault current exceeds the maximum interrupting rating of an expulsion fuse. ELF full-range current-limiting fuses and Tandem ELF fuses are designed to be mounted directly in a polymer or porcelain Type L cutout replacing the cutout expulsion fuse holder. The ELF fuse's versatile designs allow for safe capacitor protection and reduces the installation costs associated with bolted connections. See catalog sections 240-66 and 240-67 or consult your local representative from Cooper Power Systems for further information.

FUSEHOLDERS AND BLADES

100 A Fuseholder

UltraSIL polymer-insulated and porcelain Type L cutouts accommodate standard EEI-NEMA universal type fuse links. An arc shortening rod is used to obtain the higher interrupting current ratings. The arc shortening rod is made of silver-plated, high conductivity



Figure 2.
100 A disconnect blade.

copper and is mechanically attached to the fuse cap. Removable buttonhead fuse links must be used with arc shortening rods.



Figure 3.
200 A fuseholder.

200 A Fuseholder

All 200 A fuseholders (refer to Figure 3) have a unique design in which the internal arcing distance is minimized by an extended cap design. The 200 A fuse cap does not utilize an arc shortening rod allowing the use of fuse links with non-removable or removable buttonheads.

The large hexagonal cap can be easily tightened by hand or with a wrench. Its unique design easily identifies it as a 200 A fuse cap.

300 A Disconnect Blade

UltraSIL polymer-insulated and porcelain Type L 300 A disconnect blades (refer to Figure 4) are constructed of a high conductivity copper tube. 100 A fuse caps are threaded directly onto the copper tube, reducing the number of current interchanges on the blade to only two.



Figure 4.
300 A disconnect blade.

CONNECTORS/ BRACKETS

UltraSIL polymer-insulated and porcelain Type L cutouts include a tin-plated bronze parallel-groove connector as standard. The parallel-groove connector fits a conductor range of #8 solid (.128" diameter) to 250 MCM (.575" diameter). Tin plated bronze eyebolt and large eyebolt connector options are also available. The eyebolt connector fits a conductor range of #8 solid (.128" diameter) to 2/0 standard (.418" diameter) and the large eyebolt connector fits a conductor range of #8 solid (.128" diameter) to 250 MCM (.575" diameter).

UltraSIL polymer-insulated and porcelain Type L cutout crossarm mounting includes a heavy-duty NEMA Type B crossarm mounting bracket to withstand the mechanical forces generated during fault current interruptions when using an expulsion fuse link. An extended crossarm mounting bracket option is also available. Type L cutouts are also available without crossarm mounting brackets. See Table 6 for all connector and bracket options.

ELECTRICAL RATINGS

Electrical insulation ratings for the polymer and porcelain Type L cutouts are shown in Table 1.

TABLE 1
Polymer-Insulated and Porcelain Type L Electrical Ratings

Maximum Design Rating (kV)	Impulse Withstand Voltage (BIL) on 1.2x50 μ S Wave kV, crest*	Minimum 60Hz 1 min. Dry Withstand Value kV, rms*	Minimum 60Hz 10sec Wet Withstand Value kV, rms*	Creepage Distance Inches (mm)	
				Polymer	Porcelain
15.5	110	35	30	14.2 (362)	8.5 (216)
27**	125	42	36	—	11.0 (279)
27	150	70	60	22.3 (566)	17.0 (432)

Notes:

* In accordance with ANSI® Standard C37.42-1996.

** Electrical ratings apply to 27 kV, 125 kV BIL Porcelain Type L cutouts only.

TABLE 2
27 kV, 125 kV BIL Porcelain Type L Interchangeable Cutout with Fuseholder or Disconnect Blade

Base Catalog Number* Type L Cutout	Maximum Design Voltage (kV)	Continuous Current A (rms)	Interrupting Rating A (rms)		Approximate Weight lbs. (kg)
			Symmetrical	Asymmetrical	
L9C1	27	100	5,300	8,000	16.7 (7.5)
L9CA**	27	100	8,000	12,000	16.8 (7.6)
L9C2	15.5	200	7,100	10,000	17.2 (7.8)
L9C3	27	300	Disconnect†	Disconnect†	16.2 (7.3)

Notes:

* Standard Porcelain Type L unit. See Table 6 for optional connectors and brackets

** These units include an arc shortening rod and must be used with removable buttonhead fuse links.

† 300 A disconnect short time current ratings: 12 kA (Asym) momentary, 8.6 kA (Sym) 15-Cycle.

TABLE 3
15 kV, 110 kV BIL Polymer-Insulated and Porcelain Type L Interchangeable Cutout with Fuseholder or Disconnect Blade

Base Catalog Number Type L Cutout*		Maximum Design Voltage (kV)	Continuous Current A (rms)	Interrupting Rating A (rms)		Approximate Weight lbs. (kg)	
Polymer	Porcelain			Symmetrical	Asymmetrical	Polymer	Porcelain
S4B1	L4B1	15.5	100	7,100	10,000	8.2 (3.7)	14.5 (6.5)
S4BA**	L4BA**	15.5	100	10,600	16,000	8.3 (3.8)	14.6 (6.6)
S4B2	L4B2	7.8	200	8,000	12,000	8.7 (3.9)	15.0 (6.8)
S4B3	L4B3	15.5	300	Disconnect†	Disconnect†	7.7 (3.5)	14.0 (6.4)

Notes:

* Base catalog number for standard Polymer-insulated and Porcelain Type L unit. See Table 6 for optional connectors and brackets

** These units include an arc shortening rod and must be used with removable buttonhead fuse links.

† 300 A disconnect short time current ratings: 16 kA (Asym) momentary, 10.6 kA (Sym) 15-cycle.

TABLE 4
27 kV, 150 kV BIL Polymer-Insulated and Porcelain Type L Interchangeable Cutout with Fuseholder or Disconnect Blade

Base Catalog Number Type L Cutout*		Maximum Design Voltage (kV)	Continuous Current A (rms)	Interrupting Rating A (rms)		Approximate Weight lbs. (kg)	
Polymer	Porcelain			Symmetrical	Asymmetrical	Polymer	Porcelain
S9D1	L9D1	27	100	5,300	8,000	10.2 (4.6)	22.5 (10.2)
S9DA**	L9DA**	27	100	8,000	12,000	10.3 (4.7)	22.6 (10.3)
S9D2	L9D2	15.5	200	7,100	10,000	10.7 (4.9)	23.0 (10.4)
S9D3	L9D3	27	300	Disconnect†	Disconnect†	9.7 (4.4)	22.0 (10.0)

Notes:

* Standard Polymer-insulated and Porcelain Type L unit. See Table 6 for optional connectors and brackets

** These units include an arc shortening rod and must be used with removable buttonhead fuse links.

† 300 A disconnect short time current ratings: 12 kA (Asym) momentary, 8.6 kA (Sym) 15-Cycle.

DIMENSIONAL INFORMATION

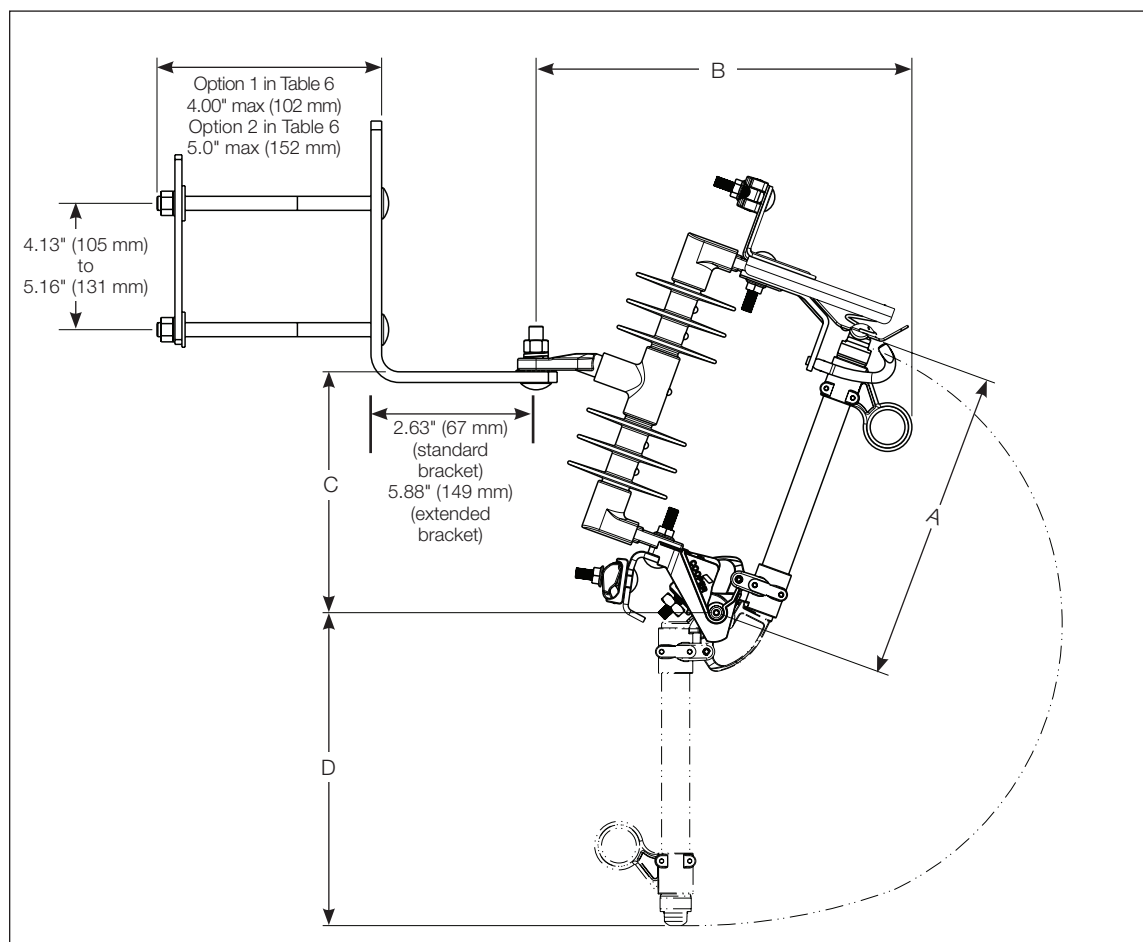

Figure 5. Polymer-insulated Type L cutout assembly shown. Dimensions apply to both polymer-insulated and porcelain Type L cutouts.

TABLE 5
Polymer-Insulated and Porcelain Type L Cutouts Dimensional Data (refer to Figure 5)

Voltage Rating kV	BIL kV	Dimensions inches (mm)				Creepage Distance inches (mm)	
		A	B	C	D	Polymer	Porcelain
15.5	110	11.32 (288)	13.50 (343)	8.15 (207)	11.50 (292)	14.2 (362)	8.5 (216)
27	125*	14.74 (374)	14.09 (358)	10.12 (257)	14.92 (379)	—	11.0 (279)
27	150	14.74 (374)	14.29 (363)	10.12 (257)	14.92 (379)	22.3 (566)	17.0 (432)

* Electrical and dimensional information applies to porcelain cutouts only.

ORDERING INFORMATION

To order a complete Type L cutout with a fuseholder or disconnect blade choose the appropriate part number from Table below.

To order an individual fuseholder, disconnect blade or the cutout mounting frame, refer to Tables 7 or 8.

TABLE 6
Polymer-Insulated and Porcelain Type L Cutout Combination Numbering System

1	2	3	4	5	6	7
S	4	B	1	E	1	A

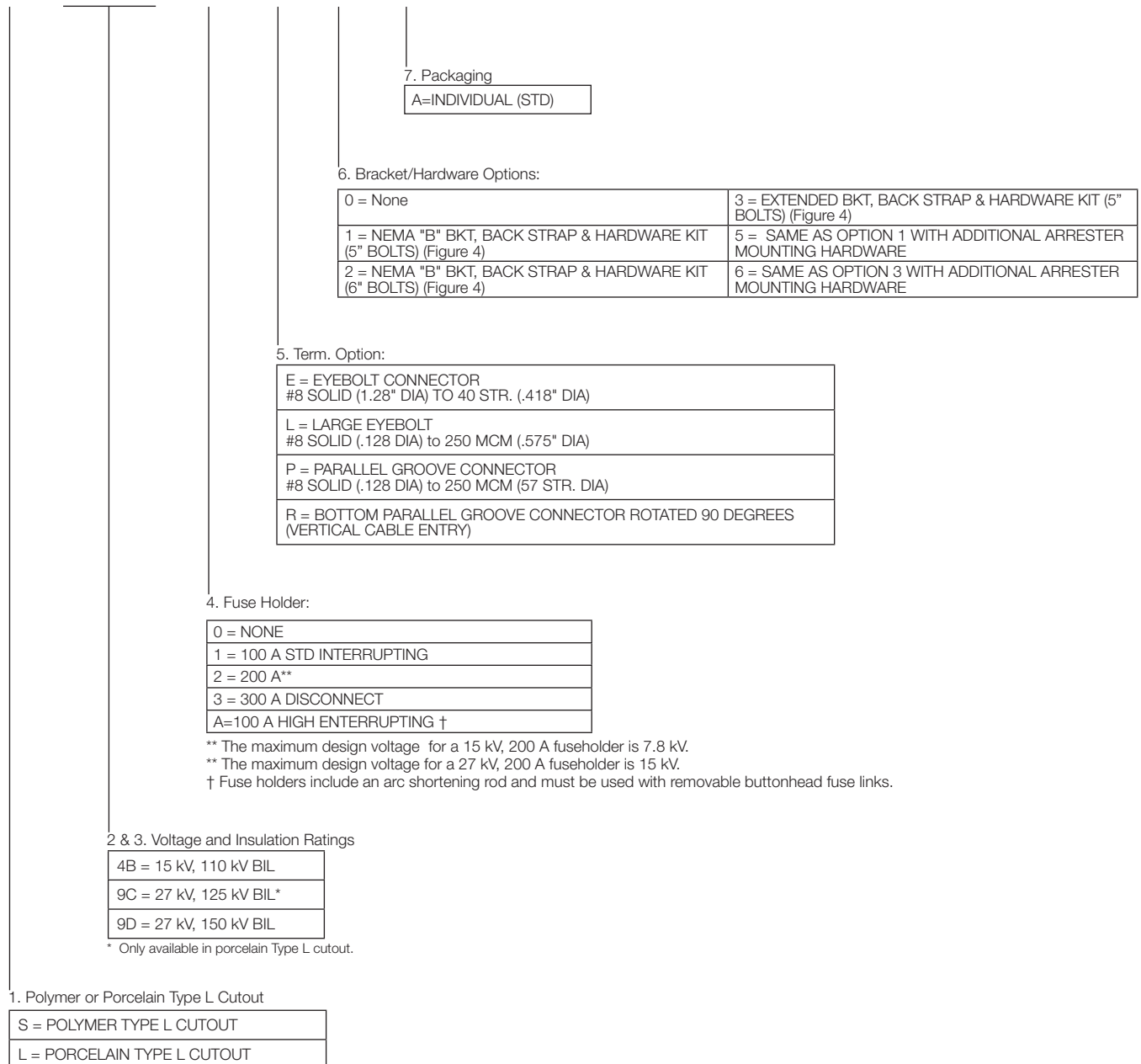

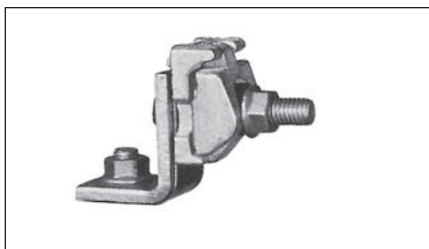

Figure 6.
Parallel-groove connector.



Figure 7.
Eyebolt connector.

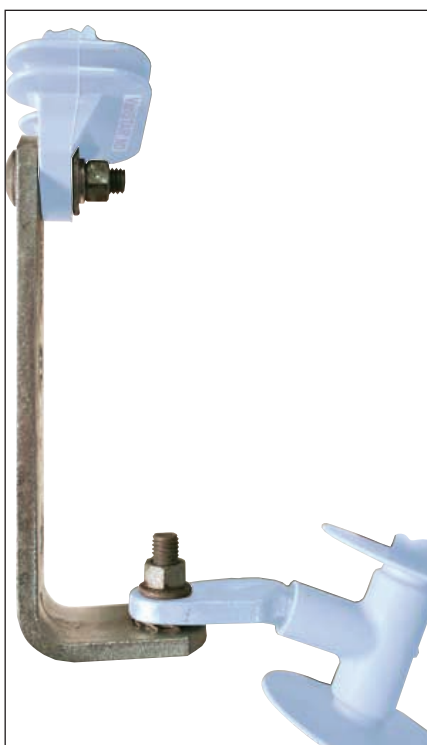

Figure 8.
Additional Arrester Mounting
Hardware (bagged) included for
Options 5 and 6.

TABLE 7
Polymer-Insulated and Porcelain Type L Fuseholders and Disconnect Blades Only

Catalog Number	Maximum Design Voltage kV	Continuous Current A-rms	Interrupting Rating A-rms Asym	Approximate Fuseholder Length Inches (mm)	Approximate Weight lbs. (kg)
For 15 kV, 110 kV BIL Cutouts					
LDB100A	15.5	100	10,000	11.32 (288)	1.9 (.86)
LDBA00A†	15.5	100	16,000	11.32 (288)	2.0 (.91)
LDB200A	7.8	200	12,000	11.32 (288)	2.4 (1.1)
LDB300A	15.5	300	Disconnect**	11.32 (288)	1.4 (.64)
For 27 kV, 125 kV BIL Cutouts					
LDC100A	27	100	8,000	14.74 (374)	2.1 (.95)
LDCA00A†	27	100	12,000	14.74 (374)	2.2 (1.0)
LDC200A	15.5	200	10,000	14.74 (374)	2.6 (1.2)
LDC300A	27	300	Disconnect**	14.74 (374)	1.6 (.73)
For 27 kV, 150 kV BIL Cutouts					
LDC100A	27	100	8,000	14.74 (374)	2.1 (.95)
LDCA00A†	27	100	12,000	14.74 (374)	2.2 (1.0)
LDC200A	15.5	200	10,000	14.74 (374)	2.6 (1.2)
LDC300A	27	300	Disconnect**	14.74 (374)	1.6 (.73)

Notes:

† These fuseholders include an arc shortening rod and must be used with removable buttonhead fuse links.

** 300 A disconnect short time current ratings: 12 kA (Asym) momentary, 8.6 kA (Sym) 15-Cycle for 27 kV disconnect and 16 kA (Asym) momentary, 10.6 kA (Sym) 15-Cycle for 15.5 kV disconnect.

TABLE 8
Polymer-Insulated and Porcelain Type L Open Cutout Mounting Frames Only (Without Fuseholder or Disconnect Blade)

Base Catalog Number* Type L Cutout		Maximum Design Voltage (kV)	BIL (kV)	Dimensional Inches (mm)		Creepage Distance Inches (mm)		Approximate Weight lbs. (kg)	
Polymer	Porcelain			UltraSIL & Porcelain	UltraSIL & Porcelain	Polymer	Porcelain	Polymer	Porcelain
				B	C				
S4B0	L4B0	15.5	110	13.50 (343)	8.15 (207)	14.2 (362)	8.5 (216)	6.6 (3.0)	12.6 (5.7)
-	L9C0	27	125**	14.09 (358)	10.12 (257)	-	11.0 (279)	-	14.6 (6.6)
S9D0	L9D0	27	150	14.29 (362)	10.12 (257)	22.3 (566)	17.0 (432)	10.3 (4.7)	20.4 (9.3)

Notes:

* See Table 6 for optional connectors and brackets.

** Electrical and dimensional information applies to 27 kV 125 kV BIL porcelain Type L cutouts only.

ADDITIONAL INFORMATION

Refer to the following reference literature for more information:

- S327-30-1 Type L Open Distribution Cutout Installation Instructions
- 235-26 Surge Arrester/Type L Fuse Cutout Combination Catalog
- CP-9618 Type L Open Distribution Cutout Certified Test Report
- K-SEC 100 Edison Links Catalog
- 327-40 Kearney Fuse Links Catalog
- S235-26-1 Surge Arrester/Type L Fuse Cutout Combination Installation Instructions

Contact your Cooper Power Systems representative for further information.

© 2010 Cooper Industries. All Rights Reserved.
All Cooper logos, Cooper Power Systems, UltraSIL, Tandem, Companion, ELF, Kearney, and Edison are valuable trademarks of Cooper Industries, in the U.S. and other countries. You are not permitted to use the Cooper Trademarks without the prior written consent of Cooper Industries.
ANSI® is a registered trademark of the American National Standards Institute.

COOPER Power Systems

2300 Badger Drive
Waukesha, WI 53188 USA
www.cooperpower.com