

Loadbreak Apparatus Connectors

200 A 25 kV Class Loadbreak Bushing Insert

GENERAL

The Cooper Power Systems 25 kV Bushing Insert threads into a universal bushing well and uses a patented design with an all copper current path. The uncomplicated nature of the current path design delivers superior, reliable performance.

Latch Indicator Ring

The latch indicator ring, located on the circumference of the bushing's collar, eliminates the guesswork of loadbreak elbow installation on the bushing insert. The bright yellow ring provides immediate feedback to determine if the elbow is properly installed on the insert. If the yellow ring is completely covered by the loadbreak elbow, it is fully latched. If the ring is visible, the elbow can be installed correctly before any problems can occur.

Internal Hex Broach

The internal hex broach allows for positive torque controlled installation. Using the optional installation torque tool, the bushing insert can be properly tightened into the bushing well without the fear of accidentally breaking the bushing well stud.

Long Insert

If additional clearance between the transformer faceplate and the high voltage underground cables is required, the long insert version is recommended. Its longer design provides an additional three inches of clearance, which may be important if there is a problem with cable congestion due to the placement of the primary and secondary cables within the transformer cabinet. This design provides easier switching and cable movement where this issue may be a concern.

The bushing insert meets all the requirements of IEEE Std 386™ standard – latest revision and is completely interchangeable with mating products that also meet IEEE Std 386™ standard. When mated with a comparably rated component, the bushing insert provides a fully shielded and submersible connection for loadbreak operation.



Figure 1. 25 kV Loadbreak Bushing Insert with latch indicator for applications in transformers, switches, and other apparatus (right). Longer version for use whenever increased clearance from the equipment faceplate and underground cables are required (left).

INSTALLATION

No special tools are necessary. The insert can be installed by hand or with the assistance of a torque tool. Using the hex-broached base (see Figure 2) and the LBI installation torque tool (see Figure 4), consistent installation can be easily achieved. Refer to Installation Instruction Sheet S500-12-1 (5000050749) for details.

PRODUCTION TESTS

Tests conducted in accordance with IEEE Standard 386™:

- AC 60 Hz 1 Minute Withstand – 40 kV
- Minimum Corona Voltage Level – 19 kV

Tests conducted in accordance with Cooper Power Systems requirements:

- Physical Inspection
- Periodic Dissection
- Periodic X-ray Analysis

TABLE 1
Voltage Ratings and Characteristics

Description	kV
Standard Voltage Class	25
Maximum Rating Phase-to-phase	26.3
Maximum Rating Phase-to-ground	15.2
AC 60 Hz 1 Minute Withstand	40
DC 15 Minute Withstand	78
BIL and Full Wave Crest	125
Minimum Corona Voltage Level	19

Voltage ratings and characteristics are in accordance with IEEE Std 386™ standard.

TABLE 2
Current Ratings and Characteristics

Description	Amperes
Continuous	200 A rms
Switching	10 operations at 200 A rms at 26.3 kV
Fault Closure	10,000 A rms symmetrical at 26.3 kV for 0.17 s after 10 switching operations
Short Time	10,000 A rms symmetrical for 0.17 s
	3,500 A rms symmetrical for 3.0 s

Current ratings and characteristics are in accordance with IEEE Std 386™ standard.

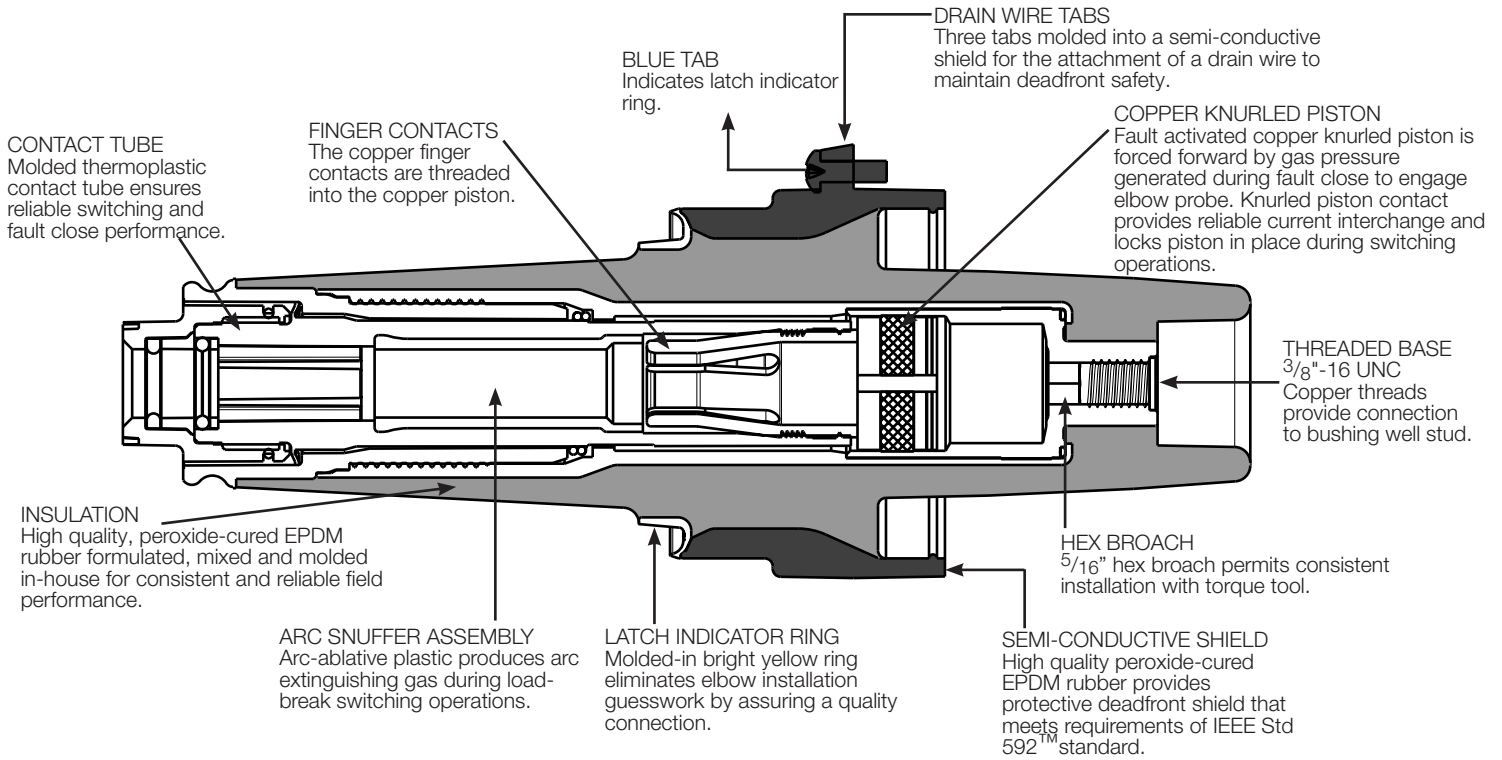

Figure 2. Bushing Insert cutaway illustrates uncomplicated nature and dependability of current path.

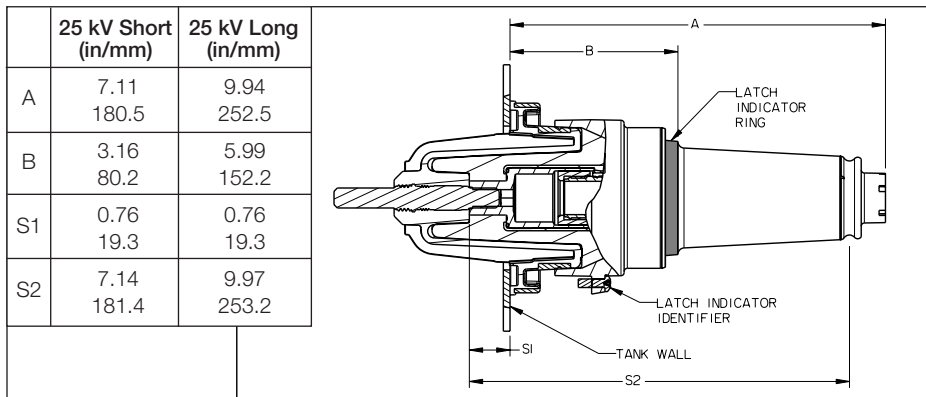

Figure 3. Bushing Insert profile and stacking dimensions, as referenced in Figure 13 IEEE Std 386™ standard.

- Each kit contains:
- Loadbreak Bushing Insert
 - Shipping Cap (not for energized operation)
 - Silicone Lubricant
 - Installation Instruction Sheet



Figure 4. Insert installation torque tool.

ORDERING INFORMATION

The standard insert kit is packaged in a sealed heavy duty polyethylene bag. Twenty five individual kits are packed to a single multi-pak box. The long version is packed 15 kits to a box. Other packaging options are also available. Please contact the factory for the appropriate part numbers. To order the 25 kV Class Loadbreak Bushing Kit, refer to Table 3.

TABLE 3
Loadbreak Bushing Insert Kit

Description	Catalog Number
Loadbreak Bushing Insert Standard Length	LBI225
Loadbreak Bushing Insert Long Version	LBI225L
Installation Torque Tool	LBITOOL

