

Molded Rubber Products

Electrical Apparatus

500-49

200 A 35 kV Class Three-Phase Loadbreak Portable Feedthru

GENERAL

The Cooper Power Systems 200 A, 35 kV Class Three-Phase Loadbreak Portable Feedthru provides two internally bused 21.1/36.6 kV loadbreak interfaces meeting all requirements of **IEEE Standard 386™** — 200 A Loadbreak Interface No. 1, 21.1/36.6 kV (large 35 kV Class interface). It is used in pad-mounted equipment, underground vaults, and other apparatus to bypass transformers, to test and ground circuits, and to provide open point deadfront lightning arrester protection when used with the Cooper Power Systems M.O.V.E. Arrester. Sectionalizing of cable runs to find and isolate cable faults is made easy when the portable feedthru is used with large 35 kV Class (21.1/36.6 kV) three-phase rated loadbreak elbows and other accessories meeting the requirements of **IEEE Standard 386™**.

The 21.1 /36.6 kV three-phase rated portable feedthru should not be used with 21.1 kV single-phase rated loadbreak elbow connectors or grounding elbows. Portable feedthrus designed for use with large interface 21.1 kV single-phase rated products are described in Section 500-48. For quick identification, Cooper Power Systems 21.1/36.6 kV three-phase rated portable feedthrus are color coded with purple nose pieces. Mating 21.1/36.6 kV three-phase rated loadbreak elbow connectors (Section 500-41) have a molded purple cuff. Single-phase rated products are color coded with tan nose pieces and molded tan cuffs. When mated with comparably rated products, the portable feedthru provides a fully shielded, submersible, separable connection for loadbreak operation.

The portable feedthru has a continuous copper current path from finger contact to finger contact. No aluminum components are used. It also has an ablative arc interrupter with excellent de-ionizing properties. The body is molded of high quality peroxide cured EPDM insulation and has a molded semi-conductive peroxide cured EPDM shield.



Figure 1. Horizontal Loadbreak Portable Feedthru; also available in vertical configuration.

The portable feedthru is designed to be installed in a double parking stand mounted on a transformer or other apparatus. It is available with either horizontal or vertical mountings. The vertical feedthru is used when parking stand configurations on apparatus will not accommodate the horizontal feedthru. In both types, the feedthru is secured in a stainless steel bracket with a stainless steel holddown bolt equipped with a brass pressure foot. The drain wire lug on the bracket allows attachment of a drain wire to ensure deadfront construction.

INSTALLATION

No special tools are required. A hotstick tool is used to place the portable feedthru in a double parking stand on the apparatus front plate. Refer to Installation Instruction Sheet S500-14-1 for details.

PRODUCTION TESTS

Tests conducted in accordance with **IEEE Standard 386™**:

- AC 60 Hz 1 Minute Withstand – 50 kV
- Minimum Corona Voltage Level – 26 kV

Tests are conducted in accordance with Cooper Power Systems requirements.

- Physical Inspection
- Periodic Dissection
- Periodic Fluoroscopic (X-ray) Analysis

TABLE 1
Voltage Ratings and Characteristics

Description	kV
Standard Voltage Class	35
Maximum Rating Phase-to-Phase	36.6
Maximum Rating Phase-to-Ground	21.1
AC 60 Hz 1 Minute Withstand	50
DC 15 Minute Withstand	103
BIL and Full Wave Crest	150
Minimum Corona Voltage Level	26

Voltage ratings and characteristics are in accordance with **IEEE Standard 386™**.

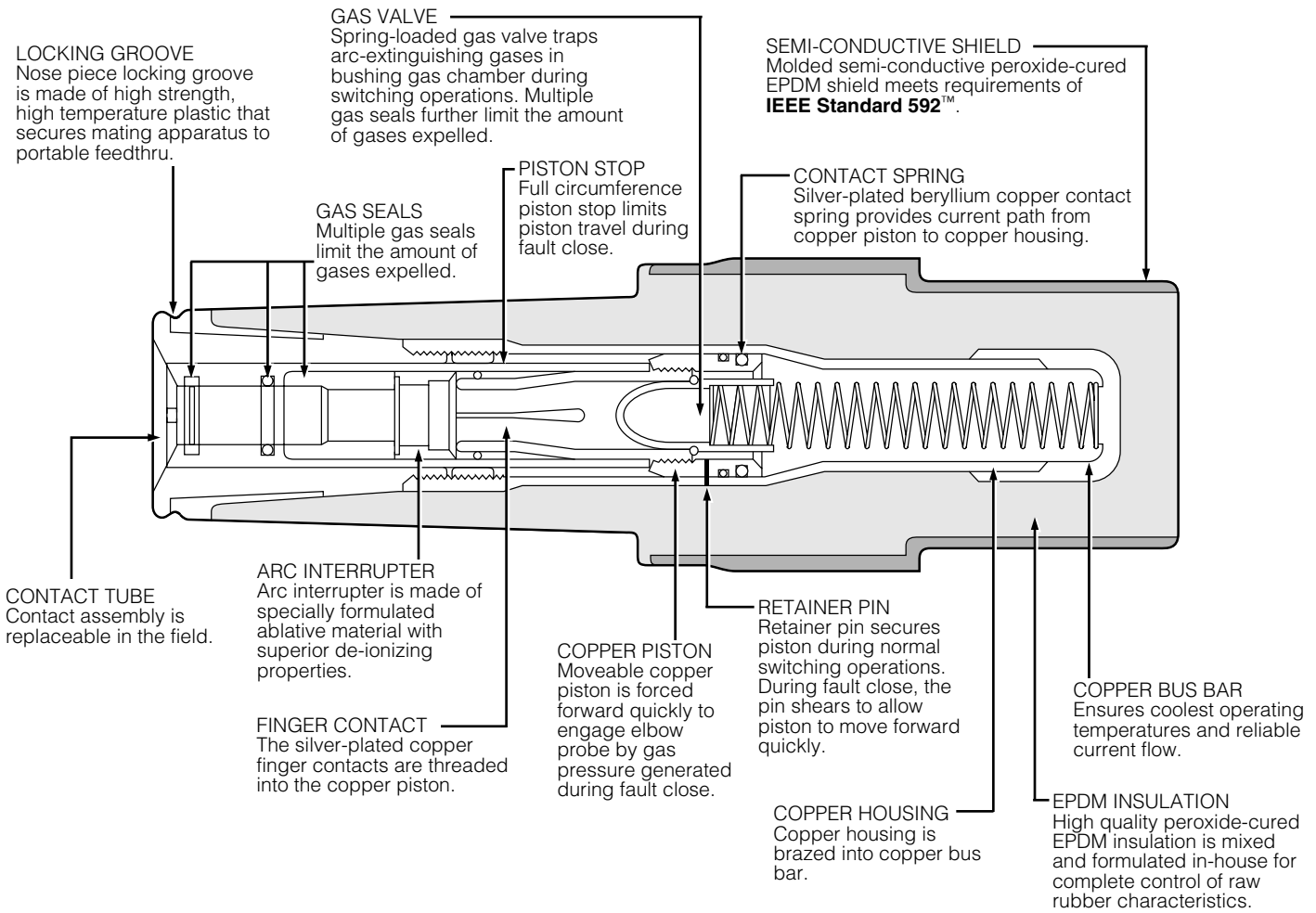

Figure 2. Illustration shows field proven, all copper current path which ensures the coolest operating temperatures and reliability.

TABLE 2
Current Ratings and Characteristics

Description	Amperes
Continuous Switching	200 A rms 10 operations at 200 A rms at 36.6 kV
Fault Closure	10,000 A rms symmetrical at 36.6 kV for 0.17 s after 10 switching operations.
Short Time	10,000 A rms symmetrical for 0.17 s 3,500 A rms symmetrical for 3.0 s

Current ratings and characteristics are in accordance with IEEE Standard 386™.

ORDERING INFORMATION

To order the 35 kV Class Three-Phase Portable Feedthru Kits, refer to Table 3.

TABLE 3
Portable Feedthrus

Description	Catalog Number
Horizontal Feedthru	LPF235H
Vertical Feedthru	LPF235V

Each kit contains:

- Portable Feedthru with Bracket
- Shipping Caps (not for energized operation)
- Silicone Lubricant
- Installation Instruction Sheet

TABLE 4
Replacement Parts

Description	Catalog Number
Contact Tube Assembly	2637407B03B
Contact Tube Replacement Tool	2637585B01
Shipping Cap	2606754A02

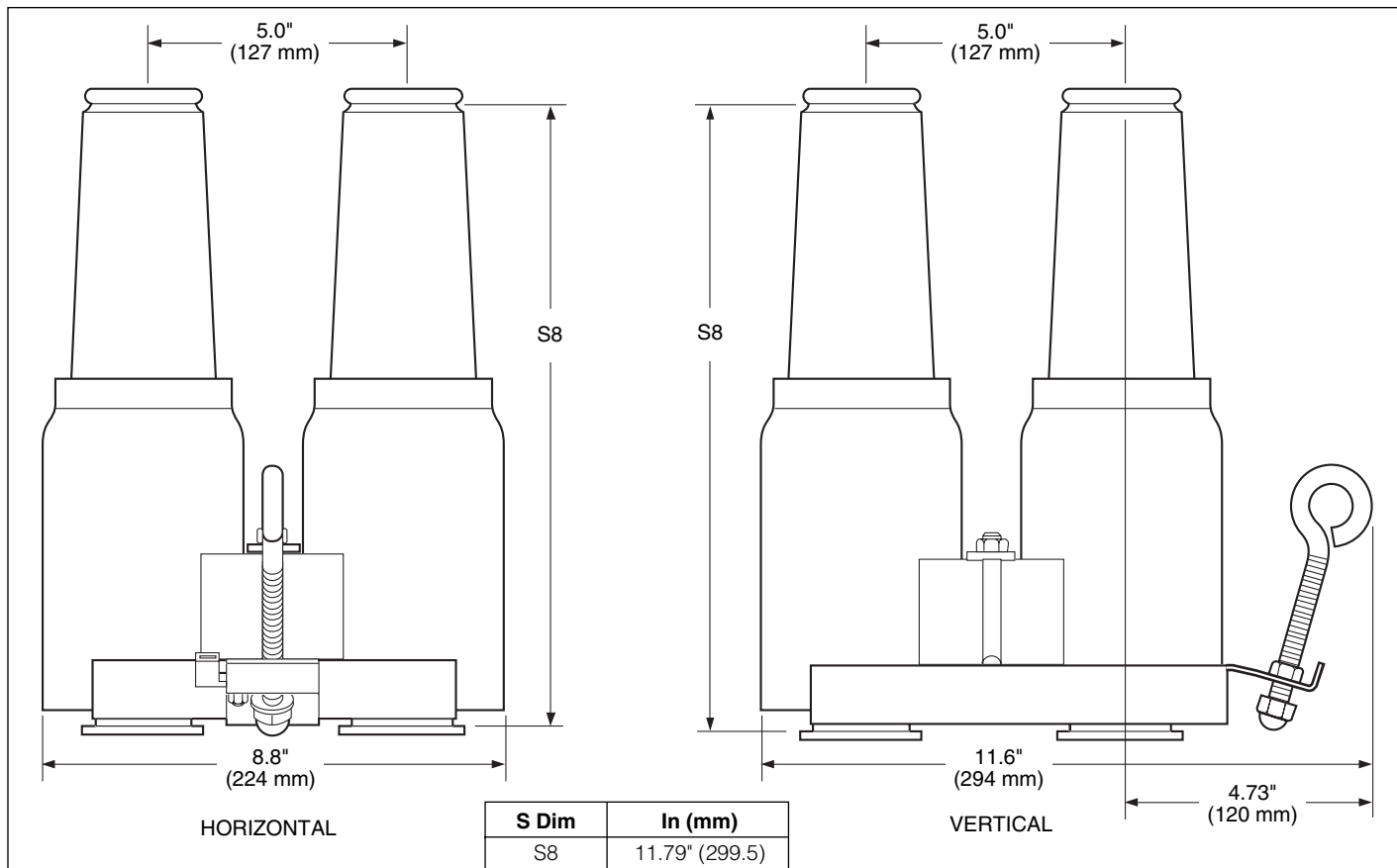

Figure 3.
Horizontal and Vertical Feedthru dimensional drawings with Brackets, Drain Wire Lugs and Eyebolts.

Note: Dimensions given are for reference only.

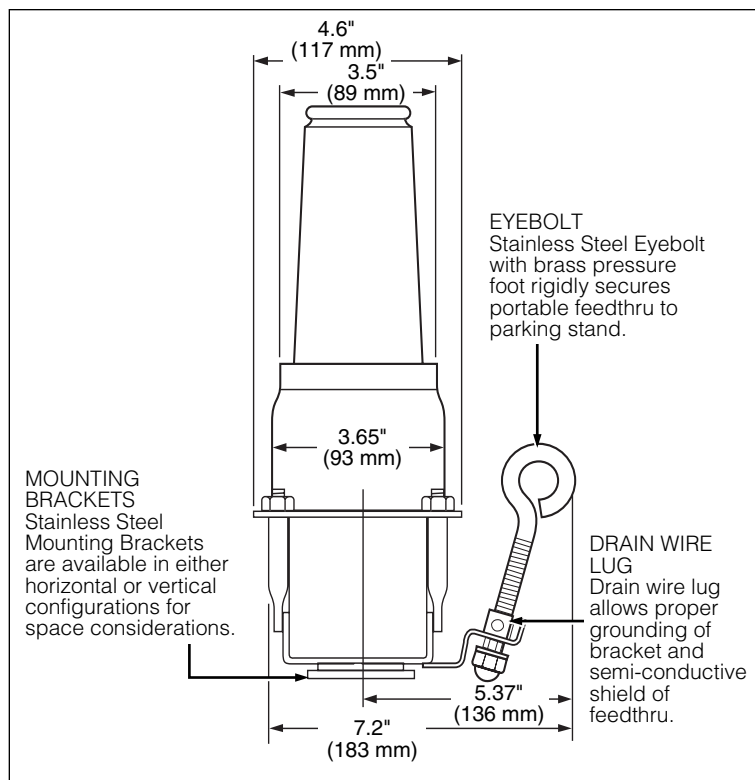

Figure 4.
Portable Feedthru sideview with Bracket, Drain Wire Lug and Eyebolt.

Note: Dimensions given are for reference only.

