

Deadbreak Apparatus Connectors

600 A 35 kV Class Bol-T Deadbreak Connector

GENERAL

The Cooper Power Systems 600 A, 35 kV Class Bol-T Deadbreak Connector is used to terminate high-voltage underground cables to deadfront apparatus such as transformers, switches and switchgear. It is fully shielded, submersible, and meets the requirements of IEEE Std 386™ standard— Separable Insulated Connector Systems.

The capacitive test point on the insulating plug provides a means of testing the circuit without disturbing the bolted connection.

In addition to the capacitive test point feature on the insulating plug, Cooper Power Systems offers an optional capacitive test point similar to the test points on Cooper's 200 A elbows. This allows the use of the Type "TPR" Series Fault Indicators, and provides a hotstick operable means of determining circuit condition when used with high impedance voltage sensing devices designed for test points.

Bol-T Connectors are designed for use on solid dielectric cable (XLPE or EPR) with extruded semi-conductive shields and concentric neutral, with or without a jacket.

Installation on jacketed concentric neutral cable may require additional sealing material. A special grounding adapter is available for tape shield, linear corrugated, unshield, and drain wire cables for use with deadbreak connectors.

900 AMP RATING

The Bol-T is rated for 900 A continuous when used with a coppertop compression connector, copper insulating plug, copper stud and copper bushing or junction. If a 900 A rating is desired, specify a "C" as the 9th digit when determining your part number. See Step 3, page 4.

INTERCHANGEABILITY

All Cooper Power Systems 600 A Deadbreak Connectors conform to the electrical, mechanical and dimensional requirements of IEEE Std 386™ standard. The connectors can be used on any comparably rated bushing interface that also meets the requirements of this standard. In addition, all cable adapters,



Figure 1. Bol-T Connector with protective cap and test point; also available without test point.

insulating plugs and compression connectors are designed to be interchangeable with those currently available from other major manufacturers that also certify their components to IEEE Std 386™ standard.

INSTALLATION

A torque wrench and one-inch socket are used to tighten the insulating plug through the compression connector within the T-Body onto a de-energized 600 A bushing interface. Refer to Installation Instruction Sheet S600-50-2 for details.

PRODUCTION TESTS

Tests are conducted in accordance with IEEE Standard 386.

- AC 60 Hz 1 Minute Withstand – 50 kV
- Minimum Corona Voltage Level – 26 kV

Tests are conducted in accordance with Cooper Power Systems requirements.

- Physical Inspection
- Periodic Dissection
- Periodic X-ray Analysis

TABLE 1
Voltage Ratings and Characteristics

Description	kV
Standard Voltage Class	35
Maximum Rating Phase-to-Ground	21.1
AC 60 Hz 1 Minute Withstand	50
DC 15 Minute Withstand	103
BIL and Full Wave Crest	150
Minimum Corona Voltage Level	26

Voltage ratings and characteristics are in accordance with IEEE Std 386™ standard.

TABLE 2
Current Ratings and Characteristics

Description	Amperes
Continuous	600 A rms
24 Hour Overload	1,000 A rms
Short Time	40,000 A rms symmetrical for 0.20 s
	27,000 A rms symmetrical for 4.0 s

Current ratings and characteristics are in accordance with IEEE Std 386™ standard.

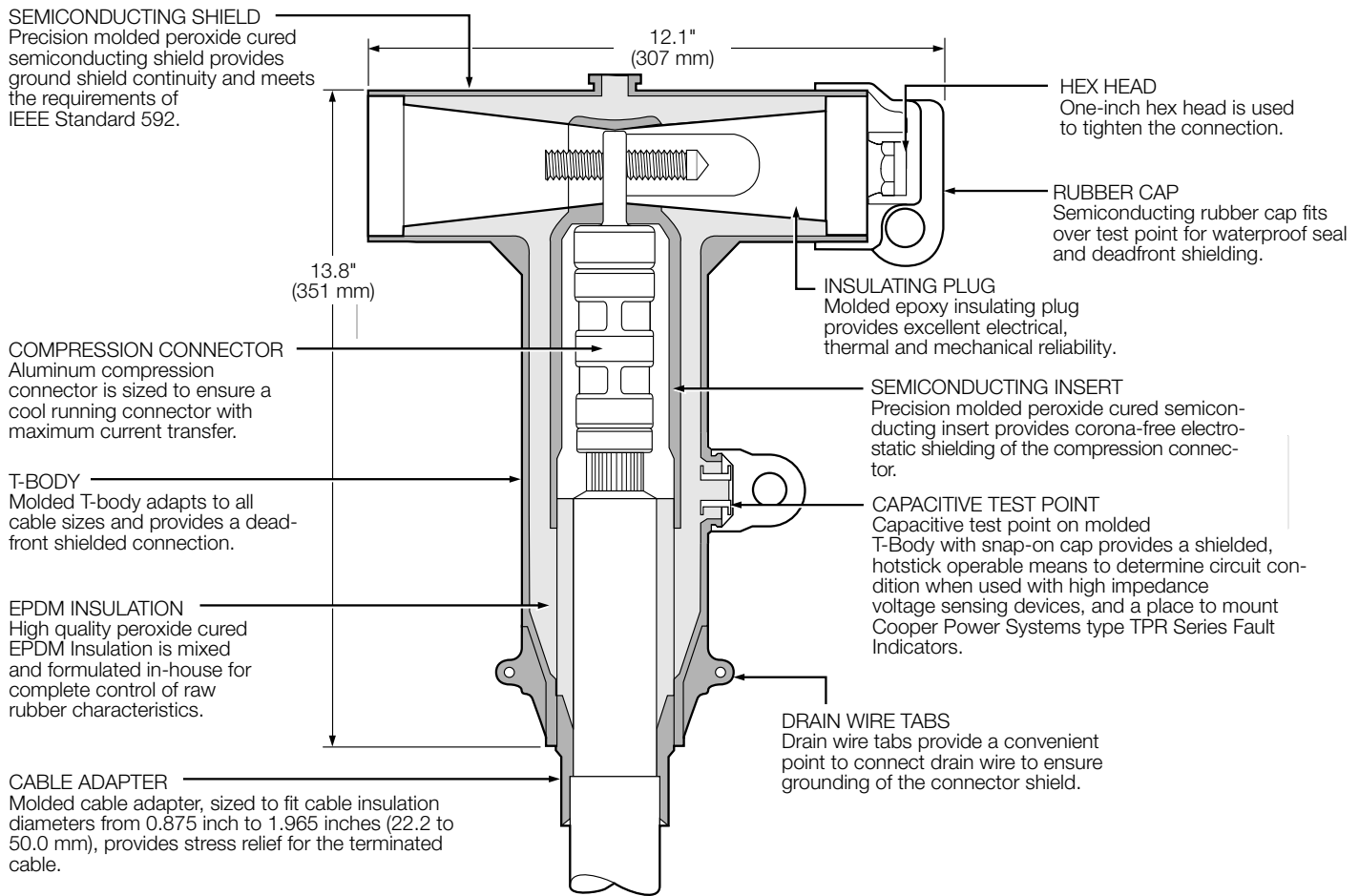

Figure 2.
Bol-T cutaway illustrates design features.

Note: Dimensions given are for reference only.

OPTIONAL FEATURES

Coppertop Compression Connectors

Coppertop compression connectors (aluminum sleeve welded to a copper spade) provide a high conductivity material in a bolted connection and are compatible with aluminum or copper conductors.

Current Path

Full copper current carrying path can be obtained by specifying a coppertop compression connector, copper stud and copper insulating plug.

ORDERING INFORMATION

Each Bol-T Connector kit contains:

- Molded Rubber T-Body
- Insulating Plug
- Cap
- Compression Connector
- Cable Adapter
- Silicone Lubricant
- Installation Instruction Sheet

To order a 35 kV Class Bol-T Connector kit, see following Steps 1-5 to build the catalog number.

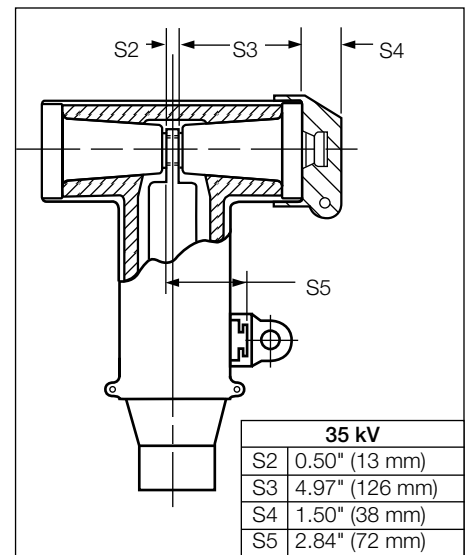

Figure 3.
Bol-T Stacking Dimensions.

Bol-T Connector Kit – Catalog Numbering System

Build the 11 digit catalog number for a Bol-T kit by following the steps given below. The first 5 digits are “BT635”, so only digits 6 through 11 need to be selected.

1	2	3	4	5	6	7	8	9	10	11
B	T	6	3	5						

CATALOG NUMBER DIGITS:

1 & 2 = “BT”, Bol-T Connector System

3 = “6”, 600 A System

4 & 5 = “35”, 35 kV Class Bushing Interface

Step 1 – Select Digit 6 Cable Adapter Range Code

Determine the cable’s diameter over the electrical insulation as shown in Figure 3 (including tolerances).

Then identify a cable range from Table 3 that covers the minimum and maximum insulation diameters.

Select the correct CABLE RANGE CODE from Table 3.

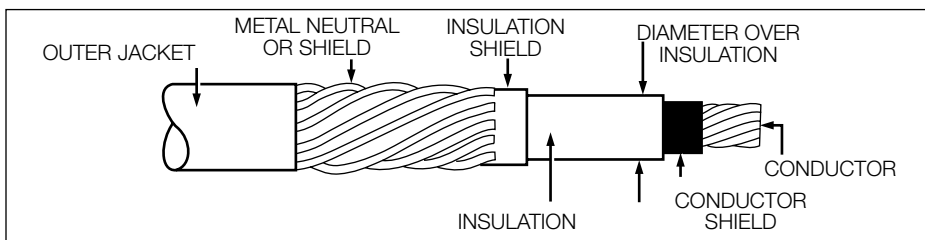

Figure 4. Illustration showing typical construction of medium voltage underground cable.

TABLE 3
Cable Diameter Range

Cable Diameter Range					
Inches	mm	Cable Range Code	Inches	mm	Cable Range Code
0.875-0.985	22.2-25.0	D	1.355-1.520	34.4-38.6	M
0.930-1.040	23.6-26.4	E	1.485-1.595	37.7-40.5	N
0.980-1.115	24.9-28.3	F	1.530-1.640	38.9-41.7	P
1.040-1.175	26.4-29.8	G	1.575-1.685	40.0-42.8	Q
1.095-1.240	27.8-31.5	H	1.665-1.785	42.3-45.3	R
1.160-1.305	29.5-33.1	J	1.755-1.875	44.6-47.9	S
1.220-1.375	31.0-34.9	K	1.845-1.965	46.9-50.0	T
1.285-1.395	32.5-35.4	L	1.960-2.210	49.8-56.1	U

Step 2 – Select Digits 7 and 8 Conductor Code

Identify the conductor size and type in Table 4 and select the CONDUCTOR CODE from the far right column.

TABLE 4
Conductor Size and Type

Concentric or Compressed		Compact or Solid		CONDUCTOR CODE
AWG or kcmil	mm ²	AWG or kcmil	mm ²	
No Connector				00
2	–	1	–	11
1	–	1/0	–	12
1/0	50	2/0	70	13
2/0	70	3/0	–	14
3/0	–	4/0	95	15
4/0	95	250	120	16
250	120	300	–	17
300	150	350	–	18
350	–	400	185	19
400	185	450	–	20
450	–	500 ^a	240	21
500	240	600	300	22
600	300	700	–	23
650 ^b	–	750 ^c	–	24
750 ^d	400	900	–	25
900	–	1000	500	26
1000	500	–	–	27
1250	630	–	–	28

a Also accepts 550 kcmil compact conductor.

b Also accepts 700 kcmil compressed conductor.

c Also accepts 800 kcmil compact conductor.

d Also accepts 700 kcmil concentric conductor.

Step 3 – Select Digit 9

Determine whether Aluminum or Copper is required for the compression connector, stud, and deadbreak insulating plug.

“A” = Aluminum

“C” = Copper (coppertop for the connector) Required to achieve 900 A rating.

Step 4 – Select Digit 10

Determine if a stud should be included in the kit. The stud will be fixed inside the deadbreak insulating plug.

“1” = Stud Included

“2” = Stud Not Included

Step 5 – Select Digit 11

Determine if the T-Body should have a test point.

“T” = Test Point on T-Body

If no test point is required, do not include an 11th digit.

EXAMPLE: Select a Bol-T kit for 250 kcmil compressed cable with a nominal insulation diameter of 1.16". The kit should have aluminum current-carrying parts and should have a stud included. The T- Body should have a test point.

Step 1 – Select Digit 6

Nominal diameter over insulation is 1.16" \pm .030".

Minimum diameter = 1.16" - .030" = 1.13".

Maximum diameter = 1.16" + .030" = 1.19".

From Table 3, identify the cable range that covers 1.13" - 1.19" and select the "H" cable range code.

Step 2 – Select Digits 7 and 8

The conductor size is 250 kcmil compressed. From Table 4, under the column "Concentric or Compressed," identify 250 kcmil and select the "17" conductor code.

Step 3 – Select Digit 9

This kit requires aluminum current-carrying parts. Select an "A" for digit 9.

Step 4 – Select Digit 10

This kit requires a stud, so select "1" for digit 10.

Step 5 – Select Digit 11

A test point is needed, so use a "T" for digit 11.

The complete catalog number is:

BT635H17A1T

ACCESSORIES

Cable Adapters, Compression Connectors, and other accessories that can be used with Cooper Power Systems' Bol-T Connectors are described in Section 600-66, "Deadbreak Accessories, Tools, and Replacement Parts."

TABLE 5
Replacement Parts

Description	Catalog Number
T-Body without Test Point	DT635
T-Body with Test Point	DT635T
Cap for Insulating Plug	DIPCAP
Aluminum Insulating Plug with Cap (No Stud)	DIP635A
Aluminum Insulating Plug with Cap and Aluminum Stud*	DIP635AS
Copper Insulating Plug with Cap (No Stud)	DIP635C
Copper Insulating Plug with Cap and Copper Stud*	DIP635CS
5/8" – 11 UNC 2A Aluminum Threaded Stud	STUD635-A
5/8" – 11 UNC 2A Copper Threaded Stud	STUD635-C

* STUD comes loose in kit, add "P" to part number for factory installation.

