

UltraSIL polymer-housed VariSTAR surge arresters 5 kA and 10 kA Class 1 IEC 60099-4 for MV systems to 36 kV



General

Eaton recognizes the advantages of polymer-housed arresters with reduced size and weight and enhanced safety in this generation of Cooper Power™ series UltraSIL® polymer-housed VariSTAR® surge arresters.

The UltraSIL polymer-housed VariSTAR surge arrester incorporates the industry recognized superior polymeric material – silicone rubber.

Using Metal Oxide Varistors (MOVs) having excellent electrical properties, these arresters provide superior overvoltage protection for MV distribution systems. Manufacturing our own MOV disks allows strict quality control over the manufacturing process from start to finish.

After production, every MOV disk must pass a series of electrical tests designed to ensure the highest individual disk quality. These MOV disks have proven their reliability and protective abilities through years of in-service use.

UltraSIL polymer-housed VariSTAR surge arresters are available in 5 kA and 10 kA Class 1 IEC 60099-4 designs.

Construction

The MOV disks are combined with aluminum end electrodes and are encapsulated in a high-strength composite wrap insulating material on our fully automated assembly line using strict quality control processes that eliminate manufacturing variances. The composite collar is cured to the MOV disk stack to form a solid insulation MOV disk module system that is inserted and bonded to the industry leading track resistant UltraSIL silicone rubber housing. This exclusive patented manufacturing process forms a secondary moisture seal under the primary silicone rubber housing seal, which makes the arrester impervious to moisture and capable of withstanding extreme electrical, environmental and cantilever load conditions. The composite wrapped UltraSIL polymer-housed VariSTAR surge arrester design represents a quantum leap in polymer arrester technology.

EATON

Powering Business Worldwide

Features and detailed description

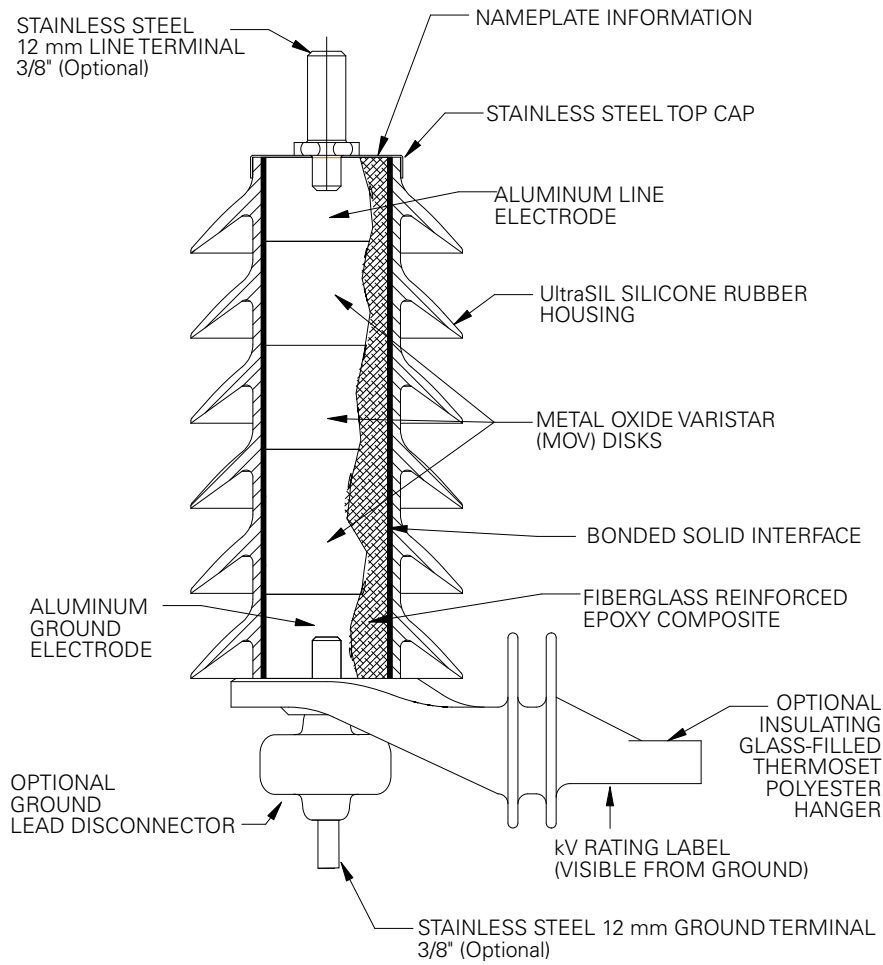

Figure 1. Cutaway illustration of an UltraSIL polymer-housed VariSTAR surge arrester.

Arrester Type	UNS	UHS
System Application Voltages	3-36 kV	3-36 kV
Rated Arrester Voltages, U_r	3-36 kV	3-36 kV
Power System Frequency	50-60 Hz	50-60 Hz
Applicable Design and Test Standard	IEC 60099-4	IEC 60099-4
Nominal Discharge Current	5 kA	10 kA
Line Discharge Class	–	1
High Current Withstand	65 kA	100 kA
Pressure Relief Class	20 kA (rms Sym.) (B)	20 kA (rms Sym.) (B)
Maximum Energy, 2000 μ s Square Wave (Repeatable 1 min)	1.83 kJ/kV U_c	2.85 kJ/kV U_c
High Current, Short Duration Energy Handling	(65 kA) 3.17 kJ/kV U_c	(100 kA) 3.9 kJ/kV U_c

Features

The UltraSIL silicone rubber housing has undergone a wide range of design tests to determine the optimum shed configuration. In addition, long term environmental testing has verified the lifetime superiority of UltraSIL silicone rubber when compared to other polymeric insulating materials.

Independent laboratory tests have verified the superiority of silicone rubber in terms of hydrophobicity, resistance to UV and surface tracking performance in contaminated environments, chemical inertness, temperature stability and other key insulating properties.

UltraSIL silicone rubber will not support biological growth (algae and mildew) and is non-flammable.

A ground lead disconnecter is optionally available for use on systems having 20 A or more of available fault current. The disconnecter will sense and disconnect the ground terminal in the unlikely event of arrester failure, preventing a permanent system short circuit. A disconnecter that has operated gives a visual indication of internal arrester damage and the need for arrester replacement. See Figure 2 for the disconnecter operating characteristics.

Customers looking to improve system reliability by minimizing wildlife related outages now have multiple options. In addition to the standard wildlife protector, featuring two self-adjusting "valve" style openings (see Figure 11 for a dimensional diagram) Eaton also offers the more robust line terminal wildlife guard. The line terminal wildlife guard is easily retrofitted to existing arrester installations and provides increased electrical insulation for the high voltage terminal of the arrester. The flexible design of the line terminal wildlife guard allows insertion of the lead wire through the bottom of the integral molded flanges. The access holes molded above the flanges will allow conductor sizes ranging from 0 to 0.50" in diameter (OD). The line terminal wildlife guard geometry allows water to shed away from the surface area of the wildlife guard while minimizing ice buildup and maintaining flexibility through extreme operating temperatures. Refer to Figure 12 for a dimensional diagram.

For complete wildlife resistance, the ground terminal wildlife guard can easily be installed alongside the line terminal wildlife guard or standard wildlife protector. The ground terminal wildlife guard is a compact and economical guard that ensures wildlife is unable to come in contact with energized objects while on a grounded surface. See Figure 13 for a dimensional diagram.

Operation

The operation of the UltraSIL polymer-housed VariSTAR surge arrester is typical of gapless metal oxide arresters. During steady state conditions, line-to-ground voltage is continuously across the arrester terminals. When overvoltages occur, the surge arrester immediately limits the overvoltage to the required protective level by conducting only the necessary level of surge current to earth. Upon passage of the overvoltage condition, the surge arrester returns to its initial condition once again, conducting only minimal leakage current.

Design testing

The housing material, internal components and hardware work as a system and stand up to years of exposure to environmental extremes. To assure a superior level of performance, the components and the assembled arrester units have been subjected to a testing program that accurately simulates years of exposure to field conditions. Tests include:

- IEC 60099-4 Testing – Full certification to performance requirements by an independent laboratory has been completed. See *CP0606, IEC UHS 10 kA Arrester Certified Test Report*, and *CP0504 IEC UNS 5 kA Arrester Certified Test Reports* for details. Additional reference documents are listed on page 17.

Routine tests

A complete automated production test program ensures a quality product. Each metal oxide varistor receives a series of electrical tests. Quality is further demonstrated by tests performed to destruction on samples from every lot of varistors.

Listed are the varistor tests performed in accordance with IEC 60099-4:

- Physical Inspection
- Discharge Voltage
- $V1\text{mA}/\text{cm}^2$
- Leakage Current at 80% of $V1\text{mA}/\text{cm}^2$ Voltage
- High Current, Short Duration Withstand
- Thermal Stability
- Aging

Each fully assembled UltraSIL polymer-housed VariSTAR surge arrester must pass the following routine tests:

- Physical Inspection
- Reference Voltage Test
UNS $I_{\text{ref}} = 3\text{ mA}$
UHS $I_{\text{ref}} = 4\text{ mA}$
- Partial Discharge Test
@ $1.05 \times U_C \leq 10\text{ pc}$

General application recommendations

The rating of an arrester is the maximum power frequency line-to-ground voltage at which the arrester is designed to pass the IEC operating duty test. Table 1 provides a general application guide for the selection of the proper arrester rating for a given system voltage and system grounding configuration.

Gapless surge arresters must be selected with sufficient steady-state self impedance to withstand the application of line-to-earth power frequency voltages under all system conditions of operation.

Continuous voltage

A preliminary selection that is based on selecting an arrester having a "Continuous Operating Voltage," or U_c , that equals or exceeds the normal system maximum line-to-earth operating voltage is made. Reference IEC 60099-5.

Power-frequency overvoltages

The second application criterion to be met is a condition established by the effectiveness of system grounding. During a single line-to-earth fault, under maximum system voltage conditions, the arrester selected should have a "Rating" (U_r) that will not be exceeded by the voltages on the unfaulted phases at the point of arrester application. One must pay particular attention to systems having low coefficients of grounding, ungrounded systems and systems that are resonant grounded or that may become ungrounded under abnormal conditions of operation. This second voltage consideration may be modified for various system conditions as long as the application does not violate the selected arrester's "Temporary Overvoltage Capability (TOV)" (see Figure 3).

Temporary system conditions resulting in sinusoidal power-frequency voltages that exceed arrester "Continuous Operating Voltage, (U_c)" or even "Arrester Rating, (U_r)" can be allowed. Consider the permissible magnitude and duration of these overvoltages (including the full time of system back-up protection), with appropriate allowances for any recent arrester discharge energies.

The voltage withstand capability application on ungrounded systems is 1.035 per unit of COV (U_c) for 24 hours. Systems which permit earth faults to remain undetected or operate with one phase earthed for periods in excess of 24 hours will require the use of an arrester having a U_c (continuous capability) equal to the system maximum phase-to-phase voltage.

Under some special system conditions, such as transformer energization using certain types of connections and ferroresonance, higher voltages can be experienced by the arrester.

Consult with your Eaton representative to have your individual system application needs reviewed.

Performance test characteristics

UltraSIL polymer-housed VariSTAR surge arresters meet the following design tests as described by IEC 60099-4:

- Operating Duty Test:**

UNS—twenty (20) current surges of 5 kA, 8/20 μ s waveshape followed by two (2) high current surges of 65 kA crest (4/10 μ s).

UHS—twenty (20) current surges of 10 kA, 8/20 μ s waveshape followed by two (2) high current surges of 100 kA crest (4/10 μ s).

- Long Duration Current Impulse Withstand Test:**

UNS—eighteen (18) current surges of 75 A, 1000 μ s duration.

UHS—eighteen (18) current surges of the energy associated with the line parameters for IEC Class 1 performance (approximately 250 A, 2000 μ s).

Following each of these tests, the arresters remain thermally stable as verified by:

- Continually decreasing leakage current values during a thirty minute power monitoring period when energized at U_c .
- No evidence of physical or electrical deterioration.
- The I_n (5 kA or 10 kA) discharge voltage measured after each test changed less than 5% from the initial values.

Full IEC 60099-4 certification has been completed and independently verified.

Table 1. Commonly Applied Voltage Ratings (U_r)

System Voltage (kV rms)		Arrester Rating — U_r (kV rms)		
Nominal	Maximum	Four-Wire Star Multi-Grounded Neutral	Three-Wire Star Solidly Grounded Neutral at Source	Delta, Ungrounded, & Resonant Impedance Grounded Star
3.3	3.7	3	6	6
6.6	7.3	6	9	9
10.0	11.5	9	12	12-15
11.0	12.0	9-10	12	12-15
16.4	18.0	15	—	18-21
22.0	24.0	18-21	24	24-27
33.0	36.3	27-30	36	36-36

Pressure relief (fault current withstand tests)

These tests demonstrate the ability to withstand fault currents for specific durations.

All UltraSIL polymer-housed VariSTAR surge arresters have been tested in accordance with the requirements listed in IEC 60099-4 and are non-fragmenting to the levels shown in Table 2.

Table 2. Pressure Relief Tests

Arrester Type	IEC Pressure Relief Class	Fault Current Amplitude (kA rms) Sym.	Minimum Fault Current Duration (Seconds)
UNS/UHS	B	0.8 20	0.5 0.2

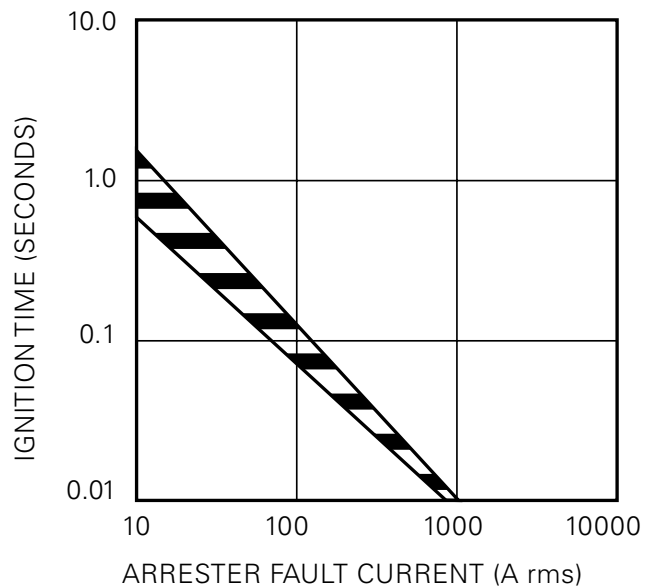

Figure 2. UNS and UHS disconnector operating characteristic.

Temporary overvoltage (TOV) capability (power frequency withstand voltage versus time characteristic)

The ability to withstand system power frequency overvoltage conditions is shown in Figure 3. The graph shows for a given voltage magnitude (on a per unit of U_C basis), the time an arrester can survive a temporary power frequency overvoltage condition and recover without thermal runaway.

Protective characteristics

UltraSIL polymer-housed VariSTAR surge arresters provide excellent overvoltage protection for electrical equipment throughout the MV distribution system.

The protective characteristics of the surge arrester family are shown in Tables 3 and 4.

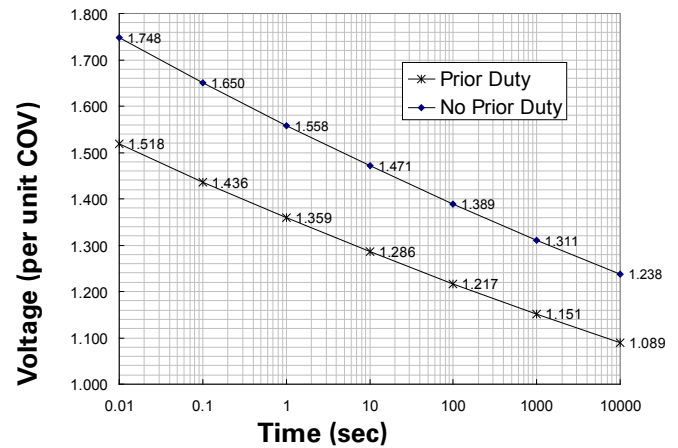

Figure 3. Temporary Overvoltage Capability (followed by U_C), 60° C ambient, UNS and UHS. The 24 hour TOV without prior duty is 1.173 per unit of U_C . The 24 hour TOV with prior duty is 1.035 per unit of U_C .

Table 3. Protective Characteristics – UNS, $I_n = 5$ kA IEC 60099-4

Ur Arrester Rating (kV rms)	Uc COV (kV rms)	Steep Current Residual Voltage (kV Crest)	Lightning Impulse Residual Voltage (kV Crest) 8/20 μ s Current Wave					
			1.5 kA	3 kA	5 kA	10 kA	20 kA	40 kA
3	2.55	10.9	9.0	9.7	10.4	11.4	13.0	15.1
6	5.1	21.8	17.9	19.4	20.8	22.7	26.0	30.2
9	7.65	31.4	25.8	28.0	30.0	32.8	37.4	43.5
10	8.4	32.7	26.9	29.1	31.2	34.1	38.9	45.3
12	10.2	41.1	33.8	36.5	39.2	42.9	48.9	56.9
15	12.7	51.3	42.2	45.7	49.0	53.6	61.1	71.1
18	15.3	61.6	50.6	54.8	58.8	64.3	73.4	85.3
21	17.0	65.4	53.7	58.2	62.4	68.2	77.9	90.6
24	19.5	76.3	62.7	67.8	72.8	79.6	90.8	106.0
27	22.0	86.3	71.0	76.8	82.4	90.1	103.0	120.0
30	24.4	96.2	79.1	85.6	91.8	100.0	115.0	133.0
33	27.0	107.0	87.8	95.6	102.0	112.0	127.0	148.0
36	29.0	115.0	94.7	103.0	110.0	120.0	137.0	160.0

Table 4. Protective Characteristics – UHS, $I_n = 10$ kA, Class 1 IEC 60099-4

U _r Arrester Rating (kV rms)	U _c MCOV (kV rms)	Steep Current Residual Voltage (kV, peak)	Lightning Impulse Residual Voltage (kV crest) 8/20 μs Current Wave						30/60 Switching Surge	
			1.5 kA	3 kA	5 kA	10 kA	20 kA	40 kA	125 A	500 A
3	2.55	10.8	8.2	8.7	9.1	9.9	10.9	12.3	7.1	7.6
6	5.1	21.5	16.3	17.4	18.2	19.8	21.9	24.7	14.1	15.1
9	7.65	32.4	24.6	26.1	27.3	29.8	33.0	37.1	21.3	22.7
10	8.4	34.4	26.0	27.7	29.0	31.6	34.9	39.4	22.6	24.1
12	10.2	43.2	32.7	34.8	36.4	39.7	43.9	49.5	28.3	30.3
15	12.7	52.2	39.6	42.1	44.0	48.0	53.1	59.8	34.3	36.6
18	15.3	64.8	49.1	52.3	54.7	59.6	65.9	74.2	42.6	45.5
21	17	68.8	52.1	55.4	58.0	63.2	69.9	78.7	45.1	48.2
24	19.5	79.5	60.2	64.1	67.0	73.1	80.8	91.1	52.2	55.8
27	22	92.4	70.0	74.5	77.9	84.9	93.9	106	60.6	64.8
30	24.4	100.5	76.1	81.0	84.7	92.4	102	115	66.0	70.5
33	27	114.2	86.5	92.1	96.3	105	116	131	75.0	80.1
36	29	120.8	91.5	97.3	102	111	123	138	79.3	84.7

Insulation withstand characteristics

Table 5. Housing Insulation Withstand Voltages, U_r 3-36 kV, UNS and UHS, $I_n = 5$ & 10 kA Class 1

Arrester Mounting Configuration	Leakage Distance (mm)	Strike (mm)															
			1.2/50μs Impulse (kV Crest)	1 min. Dry (kV rms)	1 min. Wet (kV rms)	1.2/50μs Impulse (kV Crest)	1 min. Dry (kV rms)	1 min. Wet (kV rms)	1.2/50μs Impulse (kV Crest)	1 min. Dry (kV rms)	1 min. Wet (kV rms)	1.2/50μs Impulse (kV Crest)	1 min. Dry (kV rms)	1 min. Wet (kV rms)	1.2/50μs Impulse (kV Crest)	1 min. Dry (kV rms)	1 min. Wet (kV rms)
03	183	79	Dry	47	23	92	50	36	70	44	22	85	53	29	70	42	23
04	256	106	(kV rms)	56	34	105	55	38	79	52	33	99	56	37	82	51	33
05	330	133	104	64	43	117	63	51	89	55	42	109	60	49	90	62	45
06	404	159	117	78	55	126	86	57	93	61	48	119	80	58	97	72	55
07	477	186	129	87	66	137	96	68	98	62	51	122	81	60	107	81	66
08	551	213	140	96	77	148	106	79	104	65	55	126	82	65	118	89	78
09	625	239	–	–	–	159	116	90	–	–	–	130	83	70	129	98	89
10	698	266	–	–	–	171	126	100	–	–	–	136	86	75	140	106	99
11	772	293	–	–	–	183	135	111	–	–	–	142	90	80	152	114	109
12	846	320	–	–	–	195	144	121	–	–	–	149	94	86	164	122	119
13	919	346	–	–	–	207	153	131	–	–	–	158	99	92	177	130	128
14	993	373	–	–	–	220	161	140	–	–	–	167	105	98	190	138	137
15	1067	400	–	–	–	233	170	150	–	–	–	177	112	105	204	146	146
16	1140	426	–	–	–	246	178	159	–	–	–	187	120	112	218	154	154
17	1214	453	–	–	–	259	185	168	–	–	–	199	128	120	233	161	162
18	1288	480	–	–	–	–	–	–	–	–	–	–	–	–	248	169	169
19	1361	506	–	–	–	–	–	–	–	–	–	–	–	–	264	178	176
20	1435	533	–	–	–	–	–	–	–	–	–	–	–	–	280	184	183
21	1509	560	–	–	–	–	–	–	–	–	–	–	–	–	296	191	189

Table 5a. Insulation Withstand Characteristics of Optional Insulated Mounting Bracket

Insulated Mounting Bracket	Bracket Mounting Length Center-to-Center (mm)	Leakage Distance (mm)	Strike (mm)	Power Frequency Voltage Withstand (60 sec, Wet, kV)	1.2/50µs Impulse (kV Crest)
Standard For $U_r = 3 - 10$ kV	105	150	71	36	70
Standard For $U_r = 12 - 36$ kV	127	226	99	48	80

Dimensions and clearances

Outline drawings for common options are shown. Dimensions (shown in mm) for these arrangements are listed in Table 6.

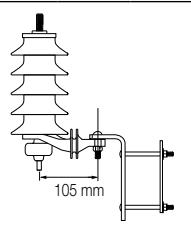
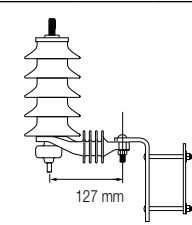
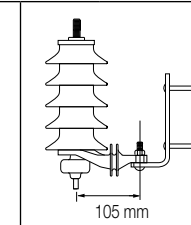
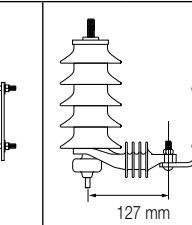
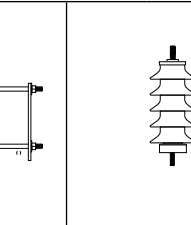
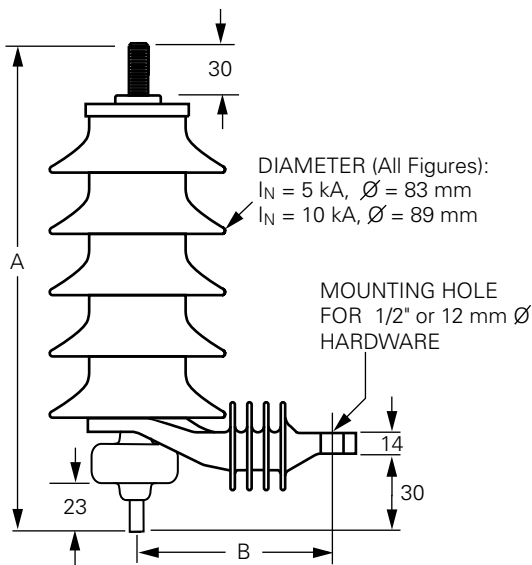

Figure 4. UltraSIL polymer-housed VariSTAR surge arrester—with optional insulated mounting bracket, and disconnecter.

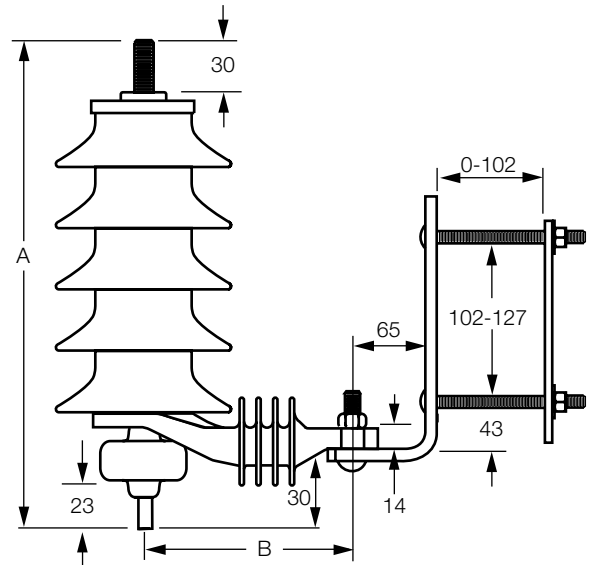

Figure 6. UltraSIL polymer-housed VariSTAR surge arrester as in Figure 4 with NEMA® crossarm hanger, see Figure 8.

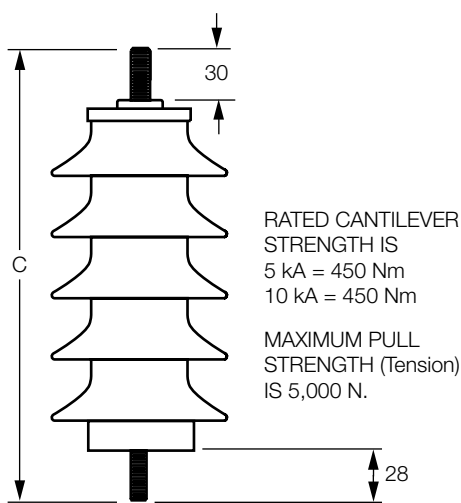

Figure 5. UltraSIL polymer-housed VariSTAR surge arrester without disconnecter, for base or cable riser mounting (arrester may be horizontal or vertical with either end at line potential).

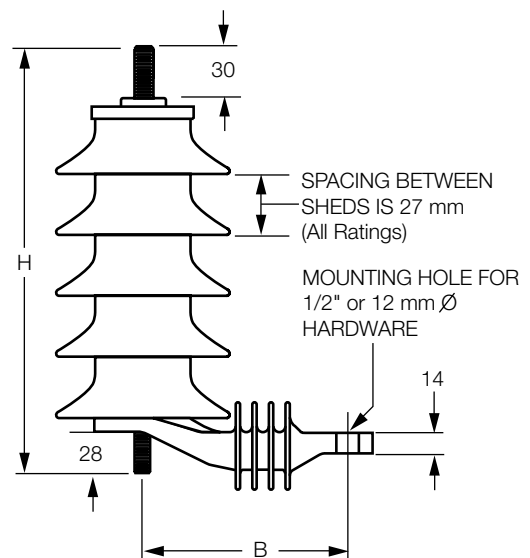

Figure 7. UltraSIL polymer-housed VariSTAR surge arrester—with optional disconnecter mounting bracket (no disconnecter).

Table 6. Dimensional Data - UNS and UHS

U _r	Housing Designation (Digits 6 & 7 Table 9)	Dimensions - Figures 4-7 page 7 (mm)			
		A	B	C	H
3-10	03	162	105	146	140
	04	190	105	174	168
	05	218	105	202	196
	06	246	105	230	224
	07	272	105	255	249
	08	300	105	283	277
12-36	06	246	127	230	224
	07	272	127	255	249
	08	300	127	283	277
	09	325	127	308	302
	10	353	127	336	330
	11	381	127	364	358
	12	406	127	390	384
	13	434	127	418	412
	14	462	127	446	440
	15	488	127	471	465
	16	–	–	499	–
	17	–	–	527	–
	18	–	–	555	–
	19	–	–	583	–
	20	–	–	611	–
21	–	–	639	–	

Table 7. Minimum Recommended Clearances

U _r Arrestor Rating (kV rms)	Clearances* Minimum Recommended (mm)			
	UNS I _n = 5 kA		UHS I _n = 10 kA	
	Phase-to-Ground	Phase-to-Phase	Phase-to-Ground	Phase-to-Phase
3	70	95	76	108
6	95	127	102	140
9	127	165	133	178
10	127	165	133	178
12	146	184	152	197
15	165	210	171	222
18	229	273	235	286
21	229	273	235	286
24	267	324	273	337
27	267	324	273	337
30	267	324	273	337
33	318	400	324	413
36	318	400	324	413

* All clearances are measured between centerlines of arresters or from centerline to earth.

Table 8. Catalog Numbers – VariSTAR Distribution-Class Surge Arresters

Arrestor Rating	With Isolator and Insulated Hanger (Figure 3)	With Isolator, Insulated Hanger and NEMA Cross-Arm Bracket (Figure 4)	With Insulated Hanger Without Isolator (Figure 6)
3	U*S0303AFDV1AA1	U*S0303AFDV1BA1	U*S0303AFAV1AA1
6	U*S0604AFDV1AA1	U*S0604AFDV1BA1	U*S0604AFAV1AA1
9	U*S0905AFDV1AA1	U*S0905AFDV1BA1	U*S0905AFAV1AA1
10	U*S1005AFDV1AA1	U*S1005AFDV1BA1	U*S1005AFAV1AA1
12	U*S1206AFDV1AA1	U*S1206AFDV1BA1	U*S1206AFAV1AA1
15	U*S1507AFDV1AA1	U*S1507AFDV1BA1	U*S1507AFAV1AA1
18	U*S1808AFDV1AA1	U*S1808AFDV1BA1	U*S1808AFAV1AA1
21	U*S2109AFDV1AA1	U*S2109AFDV1BA1	U*S2109AFAV1AA1
24	U*S2410AFDV1AA1	U*S2410AFDV1BA1	U*S2410AFAV1AA1
27	U*S2711AFDV1AA1	U*S2711AFDV1BA1	U*S2711AFAV1AA1
30	U*S3012AFDV1AA1	U*S3012AFDV1BA1	U*S3012AFAV1AA1
33	U*S3313AFDV1AA1	U*S3313AFDV1BA1	U*S3313AFAV1AA1
36	U*S3614AFDV1AA1	U*S3614AFDV1BA1	U*S3614AFAV1AA1

* Digit 2 Option: **N** = Normal-Duty, **H** = Heavy-Duty

Note: All catalog numbers listed above include a universal wildlife protector.

Table 9. UltraQUIK™ Catalog Numbering System for UltraSIL Polymer-Housed VariSTAR Surge Arresters

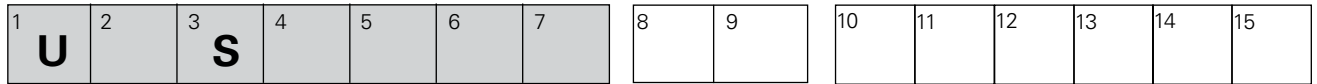

Catalog Number Digits:

- 1** = UltraSIL Polymer-Housed VariSTAR Surge Arrester
- 2** = Arrester Class:
- 3** = Arrester Type:
- 4 & 5** = Arrester Rating U_r (U_c):

- U**
- N** = I_n = 5 kA
- S** = VariSTAR
- 03** = 3 kV (2.55 kV)
- 06** = 6 kV (5.1 kV)
- 09** = 9 kV (7.65 kV)
- 10** = 10 kV (8.4 kV)
- 12** = 12 kV (10.2 kV)
- H** = I_n = 10 kA, Class 1
- 15** = 15 kV (12.7 kV)
- 18** = 18 kV (15.3 kV)
- 21** = 21 kV (17.0 kV)
- 24** = 24 kV (19.5 kV)
- 27** = 27 kV (22.0 kV)
- 30** = 30 kV (24.4 kV)
- 33** = 33 kV (27.0 kV)
- 36** = 36 kV (29.0 kV)

6 & 7 = Housing Options Per Arrester Rating – Select from Table below.

***** = Standard Housing **O** = Housing Options

Digits 6 & 7	03	04	05	06	07	08	09	10	11	12	13	14	15	16	17	18	19	20	21
Total Leakage Distance (mm)	183	256	330	404	477	551	625	698	772	846	919	993	1067	1140	1214	1288	1361	1435	1509
Arrester Rating (kV rms)																			
3	*	O																	
6		*	O	O															
9			*	O	O	O													
10			*	O	O	O													
12				*	O	O	O	O											
15					*	O	O	O	O	O									
18						*	O	O	O	O	O	O							
21							*	O	O	O	O	O							
24								*	O	O	O	O	O	O					
27									*	O	O	O	O	O	O	O			
30										*	O	O	O	O	O	O	O	O	
33											*	O	O	O	O	O	O	O	O
36												*	O	O	O	O	O	O	O

Notes:

1. Protected leakage distance is approximately 45% of total leakage distance (mm).
2. Total leakage distance shown includes 40 mm of the insulated base/mounting bracket.

Table 9. UltraQUIK™ Catalog Numbering System for UltraSIL Polymer-Housed VariSTAR Surge Arresters (continued)

1	2	3	4	5	6	7	8	9	10	11	12	13	14	15
U		S												

8 = Line Stud and Lead Options:

- 12 mm Line Terminal Options – all threaded studs are 12 mm x 30 mm long (except options L and M), stainless steel.

A = without line lead

- | | | |
|---|---|--|
| B = with 300 mm long, 5 mm diameter insulated lead wire | E = with 450 mm long, 5 mm diameter insulated lead wire | H = with 750 mm long, 5 mm diameter insulated lead wire |
| C = with 300 mm long, 5 mm diameter insulated lead wire having (1) ring terminal | F = with 450 mm long, 5 mm diameter insulated lead wire having (1) ring terminal | J = with 750 mm long, 5 mm diameter insulated lead wire having (1) ring terminal |
| D = with 300 mm long, 5 mm diameter insulated lead wire having (2) ring terminals | G = with 450 mm long, 5 mm diameter insulated lead wire having (2) ring terminals | K = with 750 mm long, 5 mm diameter insulated lead wire having (2) ring terminals |
| L = with 45 mm long stud, without insulated lead wire (will not allow use of universal wildlife protector) | M = with 65 mm long stud, without insulated lead wire (will not allow use of universal wildlife protector) | |

- 3/8" Line Terminal Options – all threaded studs are 3/8" x 1-3/16" long, stainless steel.

0 = without line lead

- | | | |
|--|--|--|
| 1 = with 12" #6 AWG insulated lead wire | 4 = with 18" #6 AWG insulated lead wire | 7 = with 30" #6 AWG insulated lead wire |
| 2 = with 12" #6 AWG insulated lead wire having (1) ring terminal | 5 = with 18" #6 AWG insulated lead wire having (1) ring terminal | 8 = with 30" #6 AWG insulated lead wire having (1) ring terminal |
| 3 = with 12" #6 AWG insulated lead wire having (2) ring terminals | 6 = with 18" #6 AWG insulated lead wire having (2) ring terminals | 9 = with 30" #6 AWG insulated lead wire having (2) ring terminals |

9 = Line Terminal Accessories

All line terminal accessory hardware is stainless steel (12 mm or 3/8" Ø, as required for digit 8)

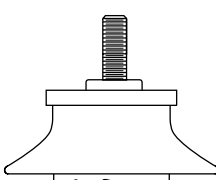
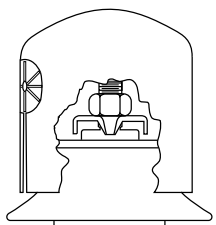
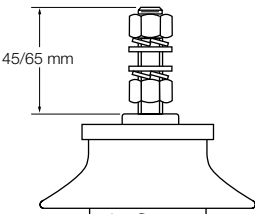
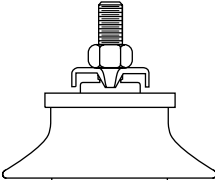
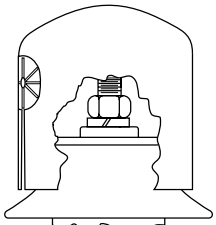
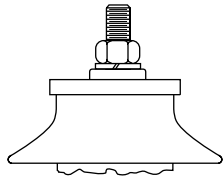
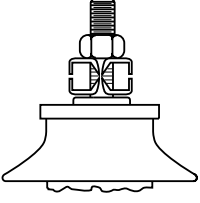
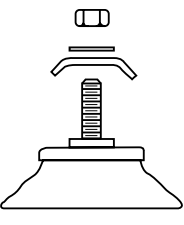
 <p>C = No Hardware</p>	 <p>F = Nut, Wire Clamp & Universal Wildlife Protector</p>	 <p>L = 2 each: Nuts, Flat Washers & Lock Washers (Requires "L" or "M" in Digit 8)</p>	 <p>R = Nut & Wire Clamp</p>
 <p>S = Nut, Lock Washer & Universal Wildlife Protector (Also for leads with ring terminals, see Digit 8)</p>	 <p>T = Nut, Lock Washer (Also for leads with ring terminals, see Digit 8)</p>	 <p>U = Nut & 2 Wire Clamps</p>	 <p>V = Wire clamp, Nut, & Flat Washer</p>

Notes:

1. Wire clamps F, R, and U will accommodate #10 solid to 2/0 AWG or to 4 mm solid diameter wire. Wire clamp V will accommodate 6 mm solid or up to 14 mm diameter stranded conductor.
2. Maximum allowable torque on line terminal is 27 Nm.
3. The universal wildlife protector may only be used with 30 mm or 1-3/16" length stud.

Table 9. UltraQUIK™ Catalog Numbering System for UltraSIL Polymer-Housed VariSTAR Surge Arresters (continued)

1 U	2	3 S	4	5	6	7	8	9	10	11	12	13	14	15
---------------	---	---------------	---	---	---	---	---	---	----	----	----	----	----	----

10 = Ground Terminal Options

12 mm ground terminal options

With ground lead disconnecter and stainless steel stud length of

D = 12 mm Ø x 25 mm
(Requires "1" in digit 12)

Without ground lead disconnecter, stainless steel stud length of

A = 12 mm Ø x 30 mm
B = 12 mm Ø x 45 mm
C = 12 mm Ø x 65 mm

3/8" ground terminal options

With ground lead disconnecter and stainless steel stud length of



1 = 3/8" Ø x 1"
(Requires "1" in digit 12)

Without ground lead disconnecter, stainless steel stud length of

0 = 3/8" Ø x 1-3/16"

11 = Ground Terminal Hardware

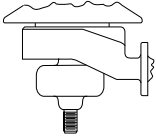
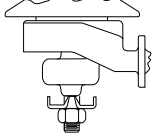
All ground terminal accessory hardware is stainless steel (12 mm or 3/8" Ø, as required for digit 10)

 <p>B = No Hardware (Shown with optional disconnecter and Insulated mounting bracket)</p>	 <p>V = Wire Clamp and Nut (Shown with optional disconnecter and Insulated mounting bracket)</p>	 <p>W = Washer, Lock Washer, and Nut</p>
---	--	---

Note: Maximum allowable torque on ground terminal is 27 Nm.

12 = Bracket Configurations

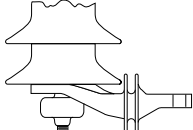
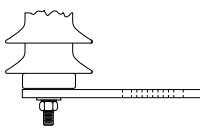
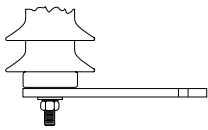
 <p>0 = Base Mounted Arrester</p>	 <p>1 = Insulated Mounting Bracket (Required with optional disconnecter) (Available only if Digits 6 & 7 are Housing Options 15 or less*) * For more information contact your Eaton representative.</p>	 <p>2 = Conductive Mounting Bracket For 3/8" Hardware (Requires "0" in Digit 10 and "W" in Digit 11) See Figure 10 for dimensional information.</p>	 <p>3 = Conductive Mounting Bracket For 12 mm Hardware (Requires "A", "B" or "C" in Digit 10 and "W" in Digit 11) See Figure 11 for dimensional information.</p>
---	--	---	---

13 = Mounting Options

<p>A = Without a Mounting Bracket</p>	 <p>B = NEMA® Crossarm Hanger (Mounting Hardware Included) (Requires "1", "2" or "3" in Digit 12) See Figure 8 for dimensional information.</p>
--	--

Table 9. UltraQUIK™ Catalog Numbering System for UltraSIL Polymer-Housed VariSTAR Surge Arresters (continued)

1	2	3	4	5	6	7	8	9	10	11	12	13	14	15
U		S												

12 & 13 = Double Digit Mounting Options with Ground Terminal Wildlife Guard

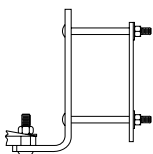
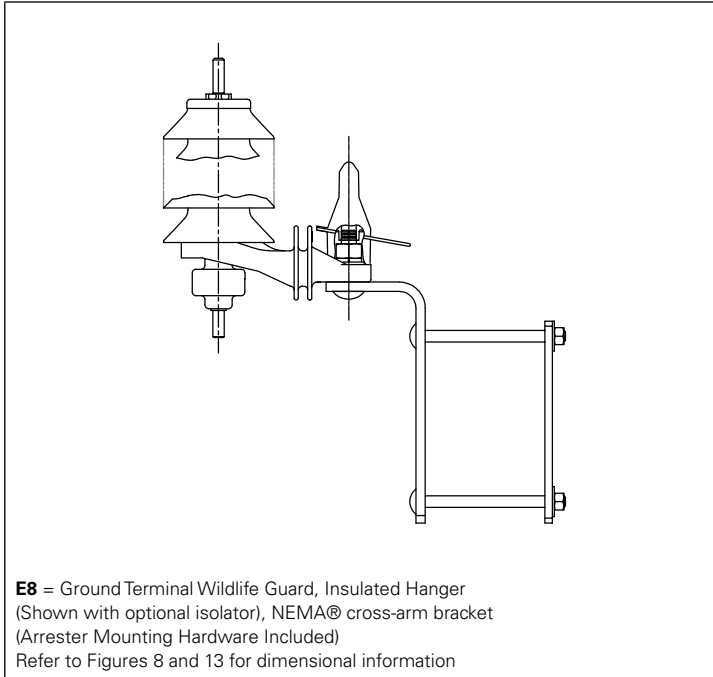

14 = Nameplate Information, See Figures 13 and 14

Nameplate information is per IEC 60099-4. Auxiliary nameplates are available in the following languages:

- A = English
- B = Español – Mexico
- C = Español – Americas
- D = Português – Americas
- E = Español – Europa
- F = Português – Europa
- G = Polski
- H = Français
- I = Norsk
- J = Suomeksi
- K = Greek
- L = Italiano
- M = Russian

15 = Packaging.

- 1 = Individual carton. Each arrester with accessories is shipped in an individual cardboard carton. Individual cartons are packed within a heavy duty quadwall carton having a skid bottom and suitable for double stacking within an ocean shipping container.
- 2 = Individual carton. Each arrester is shipped in an individual cardboard carton. Individual cartons are stacked on a pallet and shrink wrapped, suitable for shipment within NAFTA. Quantities per pallet may be adjusted to meet shipping requirements.

Accessories for the UltraSIL polymer-housed VariSTAR surge arrester

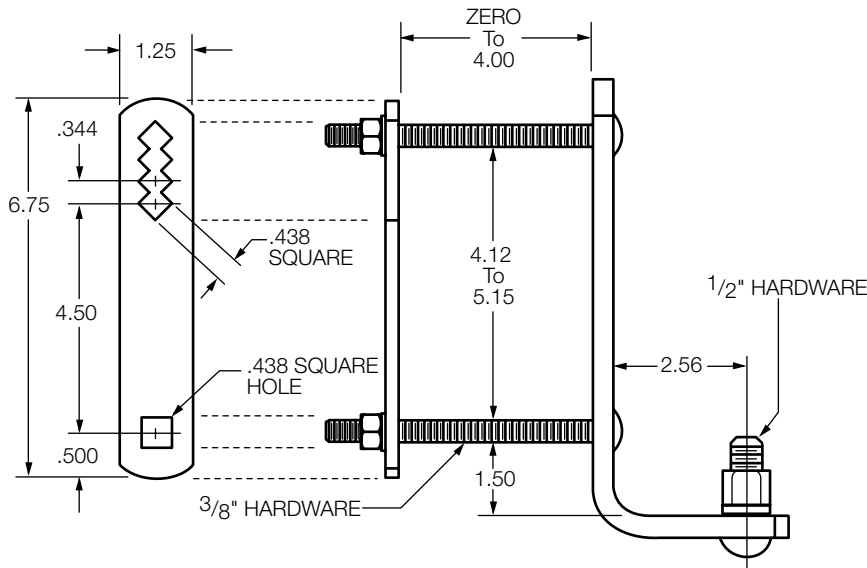

Figure 8. NEMA® crossarm hanger can be specified with a "B" in digit 13 (all dimensions are as required to be in inches, per NEMA®).

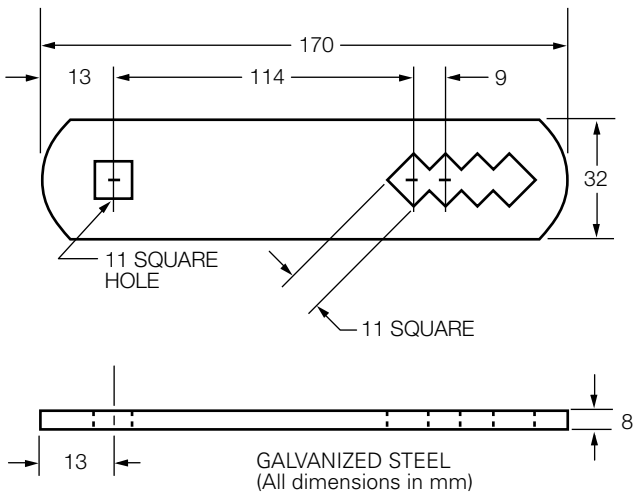

Figure 9. Conductive base mounting for use with 3/8" hardware. Can be specified with a "2" in digit 12. (Requires "0", "A", "B", or "C" in digit 10, "W" in digit 11.)

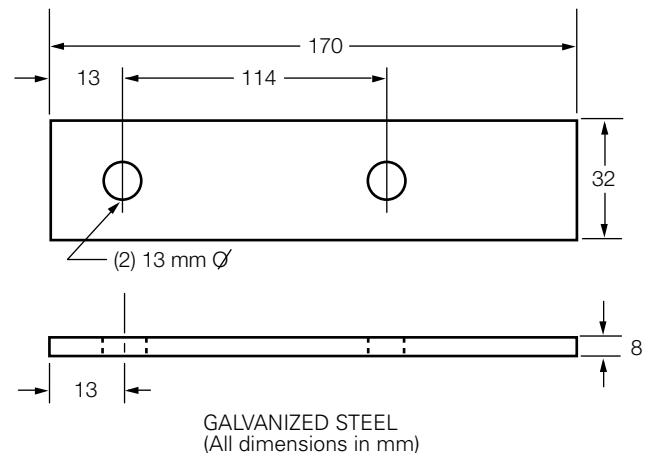

Figure 10. Conductive base mounting for use with 12 mm hardware. Can be specified with a "3" in digit 12. (Requires "0", "A", "B" or "C" in digit 10, "W" in digit 11.)

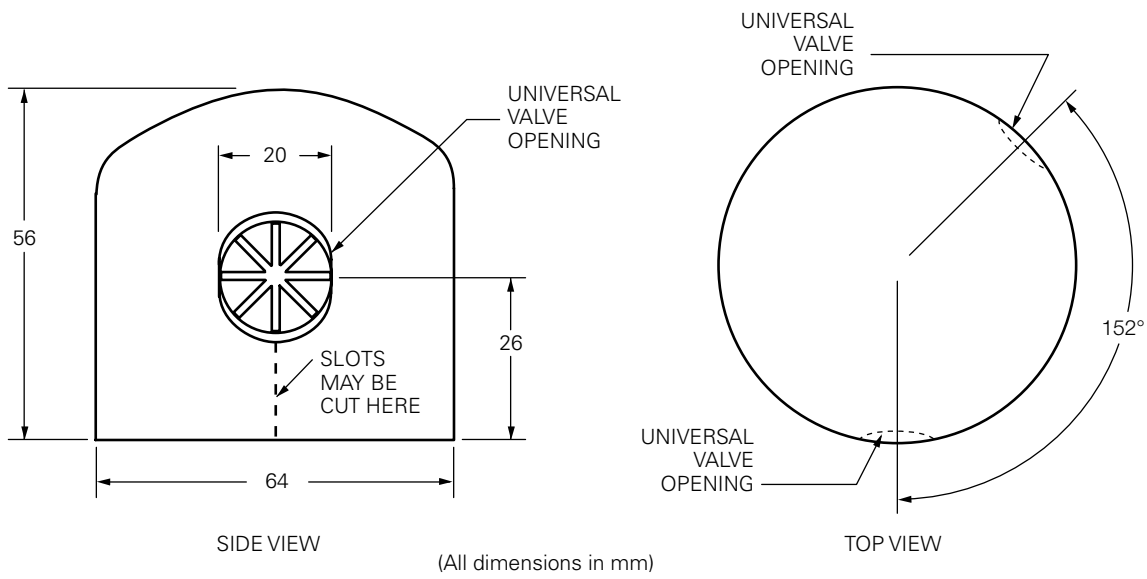

Figure 11. Universal wildlife protector for line terminal (catalog number AV346X1C) adds 5 mm to arrester height above line terminal stud. To be used only with 3/8" or 12 mm Ø line hardware of standard length, 1-3/16" and 30 mm respectively.

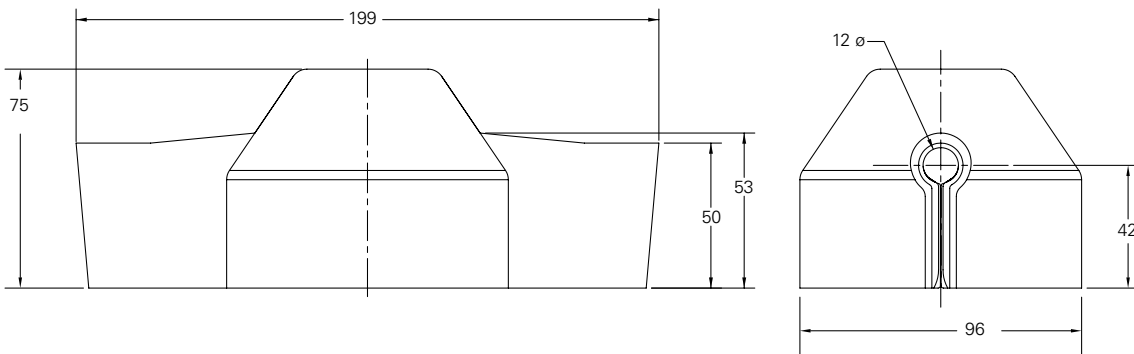

Figure 12. Optional line terminal wildlife guard (catalog number AV698X1C). (All dimensions in mm.)

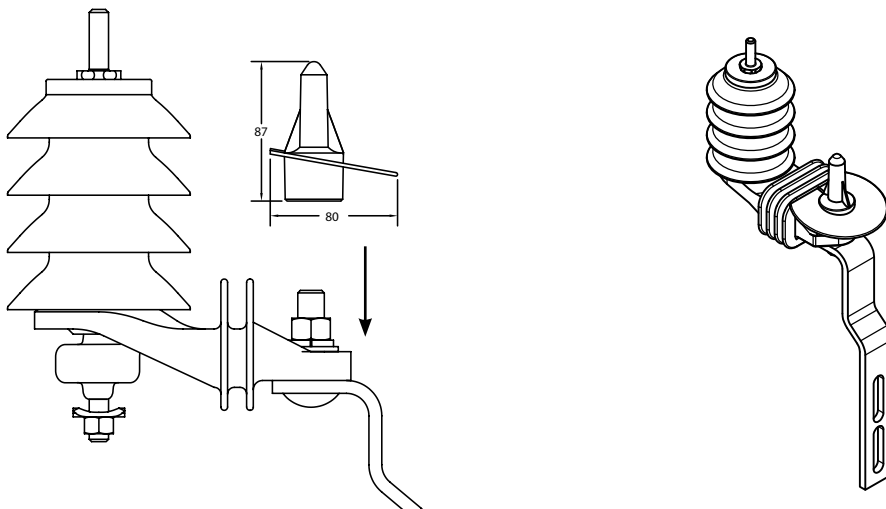

Figure 13. Optional ground terminal wildlife guard (catalog number AV731X1C). (All dimensions in mm.) Left shows attachment of ground terminal wildlife guard, right images shows ground terminal wildlife guard completely installed.

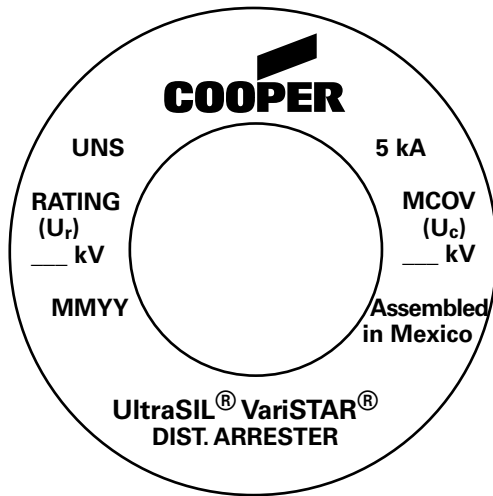

Figure 14. $I_n = 5$ kA, UNS Nameplate – stamped in stainless steel top cap.

VARISTAR® SURGE ARRESTER
ULTRASIL™ TYPE UNS-ZnO
 $I_n = 5$ kA IEC 60099-4 P.R. = 20 kA sym

(ENGLISH)

PARARRAYOS VARISTAR®
TIPO ULTRASIL™ UNS-ZnO
 $I_n = 5$ kA CEI 60099-4 AdP = 20 kA sim

(ESPAÑOL - EUROPA)

APARTARRAYOS VARISTAR®
TIPO ULTRASIL™ UNS-ZnO
 $I_n = 5$ kA IEC 60099-4 AdP = 20 kA sim

(ESPAÑOL - MEXICO)

DESC. DE SOBRET. VARISTAR®
TIPO ULTRASIL™ UNS-ZnO
 $I_n = 5$ kA IEC 60099-4 LdaS = 20 kA sim

(PORTUGUE'S - EUROPA)

PARARRAYOS VARISTAR®
TIPO ULTRASIL™ UNS-ZnO
 $I_n = 5$ kA IEC 60099-4 AdP = 20 kA sim

(ESPAÑOL - AMERICAS)

OGRANICZNIK PRZEPIEC VARISTAR®
ULTRASIL™ TYP UNS-ZnO
 $I_n = 5$ kA IEC 60099-4 Pr = 20 kA sym

(POLSKI)

PÁRA-RAIOS VARISTAR®
TIPO ULTRASIL™ UNS-ZnO
 $I_n = 5$ kA IEC 60099-4 Sp = 20 kA sim

(PORTUGUE'S - AMERICAS)

PARAFOUDRE VARISTAR®
MODÉLE ULTRASIL™ UNS-ZnO
 $I_n = 5$ kA CEI 60099-4 LdaP = 20 kA sim

(FRANÇAIS)

VARISTAR® OVERSPENNINGSAVLEDER
ULTRASIL™ TYPE UNS-ZnO
 $I_n = 5$ kA IEC 60099-4 KORTSLUTTKAP = 20 kA sym

(NORSK)

VARISTAR® YLIJÄNNITESUOJA
ULTRASIL™ TYYPPI UNS-ZnO
 $I_n = 5$ kA IEC 60099-4 RTV = 20 kA sym

(SUOMEKSI)

ALEXIKEPAYNO M.T. VARISTAR®
TYPOS ULTRASIL™ UNS - ZNO
 $I_n = 5$ kA KLASH 1 IEC 60099-4 EKT PIES = 20 kA Sym

(GREEK)

SCARICATORE M.T. VARISTAR®
TIPO ULTRASIL™ UNS-ZnO
 $I_n = 5$ kA CEI 60099-4 P.R. = 20 kA sym

(ITALIANO)

VARISTAR® ОГРАНИЧИТЕЛЬ ПЕРЕНАПРЯЖЕНИЯ
ULTRASIL™ ТИП ДИСКОВ: ЗНО Масса кг
КЛАСС=5 кА МЭК 60099-4 СБРОС ДАВЛ. = 20 кА, СИМ.

(RUSSIAN)

Figure 15. $I_n = 5$ kA, UNS Auxiliary Nameplates.

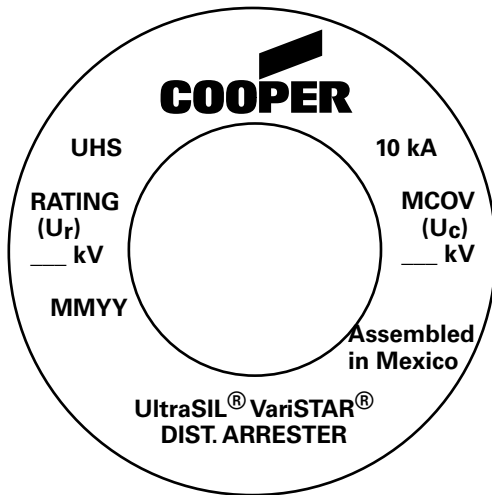

Figure 16. $I_n = 10$ kA, Class 1, UHS Nameplate—stamped in stainless steel top cap.

VARISTAR® SURGE ARRESTER
ULTRASIL™ TYPE UHS-ZnO
 $I_n = 10$ kA CLASS 1 IEC 60099-4 P.R. = 20 kA sym

(ENGLISH)

PARARRAYOS VARISTAR®
TIPO ULTRASIL™ UHS-ZnO
 $I_n = 10$ kA CLASE 1 CEI 60099-4 AdP = 20 kA sim

(ESPAÑOL - EUROPA)

APARTARRAYOS VARISTAR®
TIPO ULTRASIL™ UHS-ZnO
 $I_n = 10$ kA CLASE 1 IEC 60099-4 AdP = 20 kA sim

(ESPAÑOL - MEXICO)

DESC. DE SOBRET. VARISTAR®
TIPO ULTRASIL™ UHS-ZnO
 $I_n = 10$ kA CLASSE 1 IEC 60099-4 LdeS = 20 kA sim

(PORTUGUÊS - EUROPA)

PARARRAYOS VARISTAR®
TIPO ULTRASIL™ UHS-ZnO
 $I_n = 10$ kA CLASE 1 IEC 60099-4 AdP = 20 kA sim

(ESPAÑOL - AMERICAS)

OGRANICZNIK PRZEPIEC VARISTAR®
ULTRASIL™ TYP UHS-ZnO
 $I_n = 10$ kA KLASA 1 IEC 60099-4 Pr = 20 kA sym

(POLSKI)

PÁRA-RAIOS VARISTAR®
TIPO ULTRASIL™ UHS-ZnO
 $I_n = 10$ kA CLASSE 1 IEC 60099-4 Sp = 20 kA sim

(PORTUGUÊS - AMERICAS)

PARAFoudre VARISTAR®
MODELÉ ULTRASIL™ UHS-ZnO
 $I_n = 10$ kA CLASSE 1 IEC 60099-4 LdP = 20 kA sym

(FRANÇAIS)

VARISTAR® OVERSPENNINGSAVLEDER
ULTRASIL™ TYPE UHS-ZnO
 $I_n = 10$ kA KLASSE 1 IEC 60099-4 KORTSLUTTİKAP = 20 kA sym

(NORSK)

VARISTAR® YLIJÄNNITESUOJA
ULTRASIL™ TYYPPI UHS-ZnO
 $I_n = 10$ kA LUOKKA 1 IEC 60099-4 RTV = 20 kA sym

(SUOMEKSI)

ALEXIKEPAYNO M.T. VARISTAR®
TYPOS ULTRASIL™ UHS - ZNO
 $I_n = 10$ kA IEC 60099-4 EKT PIES = 20 kA Sym

(GREEK)

SCARICATORE M.T. VARISTAR®
TIPO ULTRASIL™ UHS-ZnO
 $I_n = 10$ kA CLASSE 1 IEC 60099-4 P.R. = 20 kA sym

(ITALIANO)

VARISTAR® ОГРАНИЧИТЕЛЬ ПЕРЕНАПРЯЖЕНИЯ
ULTRASIL™ ТИП ДИСКОВ. ЗНО Масса кг
КЛАСС=10кАМЭКИЕЦ 60099-4СБРОСДАВЛ.=20кА,СИМ

(RUSSIAN)

Figure 17. $I_n = 10$ kA, Class 1, UHS Auxiliary Nameplates.

Additional information

- MN235XXXEN, UltraSIL Polymer-Housed VariSTAR Surge Arresters IEC 60099-4 for MV Systems to 36 kV Installation Instructions
- B235-08022, Superior Protection for Arresters and Wildlife
- CP0504, Design Test Report Summary, 5 kA
- CP0606, Design Test Report Summary, 10 kA
- CP1210*, CESI Water Immersion Test for Isolator, IEC 60099-4, Edition 2.2 (2009-05)
- CP1211*, CESI Isolator Disconnecter Operation Test for Isolator, IEC 60099-4, Edition 2.2 (2009-05)
- CP1212*, CESI Long-Duration Current Impulse Withstand Test for Isolator, IEC 60099-4, Edition 2.2 (2009-05)
- CP1213*, CESI Operating Duty Test for Isolator, IEC 60099-4, Edition 2.2 (2009-05)

* Contact your Eaton representative.

Eaton

1000 Eaton Boulevard
Cleveland, OH 44122
United States
Eaton.com

Eaton's Cooper Power Systems Division

2300 Badger Drive
Waukesha, WI 53188
United States
Eaton.com/cooperpowerseries

© 2016 Eaton
All Rights Reserved
Printed in USA
Publication No. CA235029EN

Eaton is a registered trademark.

All other trademarks are property
of their respective owners.



Powering Business Worldwide