

SF₆ Gas Reclaimers

Economy Series

Save time and money on all your SF₆ maintenance work.

- Nearly 100% SF₆ gas recovery
- Reclaim to "near new" condition
- Safe, easy to use
- Fool proof, fully automatic operation with DILO's exclusive **ARPS** control system
- Lowers training costs
- CFC-free liquefaction
- Most standard features of anything on the market
- Modular construction
- Flexible--trailer or castor mountings

Application

SF₆ use in insulated switchgear is growing exponentially. At the same time, the amount each contains keeps getting smaller and smaller. The **Economy Series** SF₆ gas carts are designed for these smaller applications. They meet or exceed world standards for purity of reclaimed SF₆ AND are oil free. Their modular construction gives you the flexibility to "unplug" components should repairs ever become necessary. Even the trailer can be replaced if damaged. Ultimate versatility, convenience, and the latest in DILO's exclusive state-of-the-art **ARPS** control system--the best in technology from the world leader. **Economy** series reclaimers offer all functions needed to make reuse of reclaimed SF₆ gas safe and economical.

Functions

Economy models are full featured gas carts. They can perform all functions necessary to reclaim and purify SF₆ gas to near new condition.

- **Removal** and **storage** of SF₆ to achieve 99+% recovery
- **Automatic cleansing** during removal and filling.
- **Flushing** the gas compartment with ambient air, dry air, or nitrogen.
- **Evacuation** of gas compartment to remove air and moisture before filling.
- **Refilling** with reclaimed "near new" SF₆ from the storage vessel or with new gas.



Features

- 100% oil free and gastight DILO compressors
- Original, self-sealing DILO couplers
- All internal fittings use exclusive DILO metal-to-metal seals
- Freon™ free liquefaction
- Modular replacement of ANY component --even the trailer!
- Quick change filter systems
- State-of-the-art ARPS control
- Thoughtful design and exquisite craftsmanship provides years of reliable DILO service

Visit our home page on the World Wide Web at: <http://www.dilo.com>

Adapted to your requirements. . .

Offering a wide variety of models, the **Economy** series can be ideally suited to your needs.

From small indoor systems on lockable steering rollers, all the way up to mobile, weather protected and trailer mounted units which include such amenities as tool boxes, lockable storage compartments for measuring devices and night operation illumination, you'll find an **Economy** version to meet your needs.

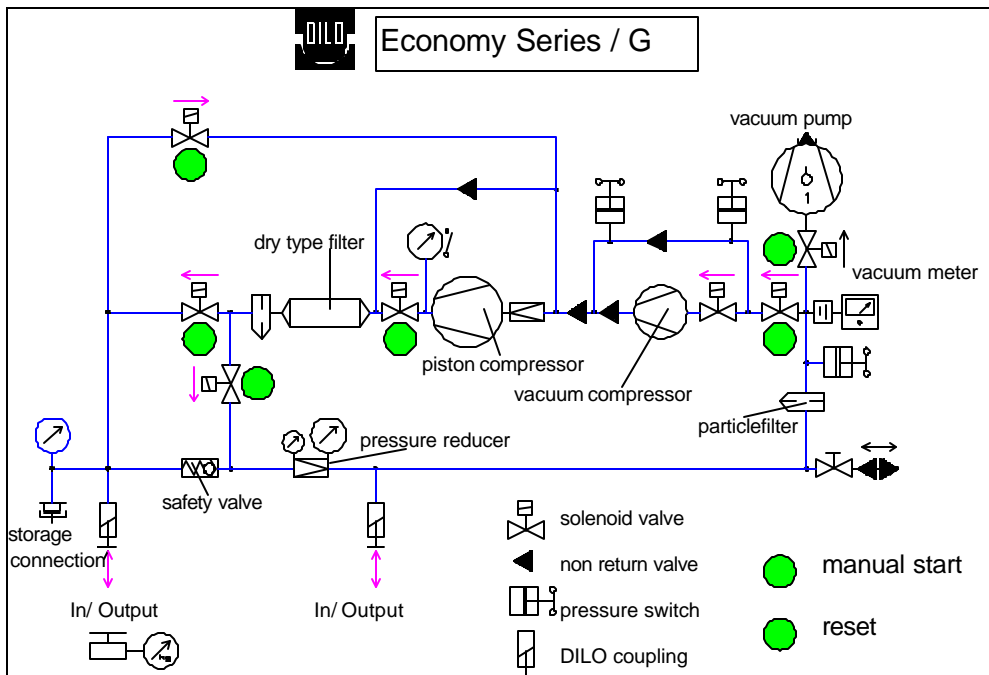

ARPS Process oriented control

The **Economy Series** is equipped with an automated ARPS control process *with* manual override capability. This innovative design protects not only your workers and the equipment itself, but also prevents inadvertent SF₆ contamination due to human error. Advanced Routing and Processing System (**ARPS**) allows each function to be run either through preprogrammed selections or manually.

Prices and Delivery

Each model consists of the same time-tested components that built DILO's reputation as quality leader the world over for nearly 40 years. They're just packaged into modular assemblies. These sub-components are now manufactured in larger quantities, allowing us to combine the variety and flexibility our customers demand with the affordability and short delivery periods the industry has come to expect.

DILO Company, Inc.
 11642 Pyramid Drive
 Odessa, FL 33556
 ☎: (727) 376-5593
 Fax: (727) 372-0277

SF₆ Economy Series

Data, Options



Modules	Order Number	
<input type="checkbox"/> Economy processing module for liquid storage Automatic/Manual control with: superimposed flow diagram; 240 CFH oil free compressor, final pressure 725 PSI; 185 CFH diaphragm compressor; 29 CFM/ 0.1 mmHg vacuum pump; evaporator unit; two dust filter units; one decomposition/moisture removal filter units; and timed meters for vacuum pump, main and diaphragm compressors. All <i>physical</i> manual control valves are eliminated.	EL – B120R51 Length: 64 in Width: 38 in Height: 42 in Weight: 1,050 lb.	
<input type="checkbox"/> Economy processing unit identical to B120R51 (above) but with upgraded 1100 CFH (0.1 torr) vacuum compressor	EL-B120R53	
Upgrade Options		
<input type="checkbox"/> Vacuum pump upgrade to 45 CFM/ 0.1 Torr . Including exhaust filter	E-V45/0.1	
<input type="checkbox"/> Vacuum pump upgrade to 75 CFM/ 0.1 Torr . Including exhaust filter	E-V75/0.1	
<input type="checkbox"/> Vacuum pump upgrade to 145 CFM/ 0.1 Torr . Including exhaust filter	E-V145/0.1	
Storage Modules for liquid processing units (EL):		
<input type="checkbox"/> Storage module for 4 parallel switched 115 lb cylinders installed for liquid processing module only. With weighing scale showing net weight of SF ₆ in lb. Includes DOT 3AA2015 cylinders Additional Weight 825 lb. Combined cart dimensions →	EL-C400-W. length 70" width 52" height 52"	
<input type="checkbox"/> Storage module for 8 parallel switched 115 lb cylinders installed for liquid processing module only. With weighing scale showing net weight of SF ₆ in lbs. Includes DOT 3AA2015 cylinders. Additional Weight 1,600 lb. Combined cart dimensions →	EL-C800-W. length 70" width 52" height 68"	
Options:		
Trailer: See attached trailer options sheet for available trailers	See attached page	
Supply Voltage		
Please indicate the actual desired supply voltage with all inquiries and orders:		
<input type="checkbox"/> within the range from 208 - 460 V / 50-60 Hz, three phase		
<input type="checkbox"/> outside the range from 208 - 460 V / 50-60 Hz, three phase	6-0004-R031	
<input type="checkbox"/> single phase additional weight: 210 lb.	MA-1B-RVS	
Accessories/misc.:		
<input type="checkbox"/> Connecting hose DN 20 with VK/F-02/20 couplings on each end. (a quantity of two is recommended), length 16 foot.	6-1017-R050	
<input type="checkbox"/> Hose Connector to connect two hoses together ML1-AD22-55	2.0401	
<input type="checkbox"/> Adapter Kit DN20 Includes adapters from DN20 to the following: 1" Male NPT; 3/8" Female JIC; 1/4" Female JIC; 1 1/4" Parker (ITE, Westinghouse, ABB PA); ABB Malmquist; DILO DN8; SF6 Cylinder; & waterproof case with extra storage compartments (analyzer kit pictured)	Adapter Kit-DN20 width: 21.2" (538 mm) height: 16" (406 mm.) depth: 8.3" (211 mm.) wt.: 23 lb. (10.5 kg.)	
<input type="checkbox"/> Replacement Filter Material Aluminum Oxide and 4A Molecular Sieve for approximately 2.5 filter replacements.	3-376-06	
<input type="checkbox"/> Drum-switch Allows reversing the phasing sequence without changing wires	3-871-R002	
<input type="checkbox"/> Special gauge indications indications other than PSI for gauges and mmHg for vacuum gauge		
<input type="checkbox"/> External Cylinder Weight Scale designed to allow user to roll cylinders onto platform without lifting. Battery operated or 120/220 VAC, range 0-330 lbs, L: 15" W: 17" H: 31" weight 44 lbs	K091R37	
<input type="checkbox"/> Hand Held SF6 Leak Detector	3-033-R002	

Shown prices are valid per piece in US \$, ex works Odessa, no taxes or packing charges included.

Trailer Options



Data, Options

All DILO trailers include the following standard features:

- DOT Approved
- All aluminum walk-in enclosure
- Torflex axles
- Electric breaks
- 3" Pintle eye, w/adjustable height
- Breakaway switch
- Spare tire
- 3/16" steel deck
- Split rear door
- 30" side door service
- Rear stabilizing jacks

Module	Processor	Order No.	
<input type="checkbox"/> Single axle trailer, 10' x 6' x 7" 7,000 lb. GVW Combined cart dimensions : length 14', width 86", height 102" Additional weight: 1,750 lb.	Compact, Economy or Performance w/no more than 8 bottles.	T-106-70	
<input type="checkbox"/> Dual axle trailer, 12' x 7' x 7" 14,000 GVW Combined cart dimensions : length 16', width 98", height 102" Additional weight: 2,420 lb.	Performance or Mega w/no more than 10 bottles storage.	T-127-140	\$
<input type="checkbox"/> Dual axle trailer, 14' x 7' x 7" 14,000 GVW Combined cart dimensions : length 18', width 98", height 102" Additional weight: 2,750 lb.	Performance or Mega w/no more than 20 bottles storage	T-147-140	
<input type="checkbox"/> Dual axle trailer, 16' x 7' x 7" 14,000 GVW Combined cart dimensions : length 20', width 98", height 102" Includes compartement for generator. Additional weight: 2,450 lb.	Performance or Mega w/no more than 10 bottles storage.	T-167-140	
<input type="checkbox"/> Dual axle trailer, 18' x 7' x 7" 14,000 GVW Combined cart dimensions : length 22', width 98", height 102" Includes compartement for generator. Additional weight: 2,650 lb.	Performance or Mega w/no more than 20 bottles storage	T-187-140	
<input type="checkbox"/> Trailer Deluxe Package Interior shop lights, 120 V / 60 hz outlets, hose hangers	All Units.	TDP	
<input type="checkbox"/> Diesel Generator Kit – 22kW Requires T167-140 trailer, adds 900 lbs. to trailer.	Compact, Economy, and Performance	MEC22DO	
<input type="checkbox"/> Diesel Generator Kit – 35kW Requires T167-140 trailer, adds 1,100 lbs. to trailer.	MEGA	MEC35DO	



Dual axle trailer shown with optional 35kW diesel genset

Trailer Colors

Standard color is white

The following colors are available for additional charge: Black, Teal, Red, Lt. Gray, Dark Gray, Navy Blue, Burgundy