

LIQUID LEVEL GAUGE

FEATURES

- Easy to see, high contrast float
- Easy to see, black and red indication
- Heavy-duty, one piece Brass body
- Large viewing window
- Indicates large liquid level span
- Unique double seal design
- Excellent light refraction from prismatic cone
- Crystal clear, polished optical rod
- Positive high and low indication
- Precision, 1"-11 1/2 NPT threaded mounting
- Large wrench flat area
- Meets Industry Standards



HLG-1065 MODEL

The HLG-1065 is one model in the Heartland HLG family of liquid level gauges.

APPLICATION The Heartland model HLG-1065 liquid level gauge indicates the oil level in transformers, regulators and other electrical equipment. The HLG-1065 meets the Industry Standards for oil level indication in electrical equipment. Heartland Solution's HLG-1065 reliably indicates the oil level in either indoor or outdoor transformer, regulator and other electrical equipment applications.

TECHNICAL DATA

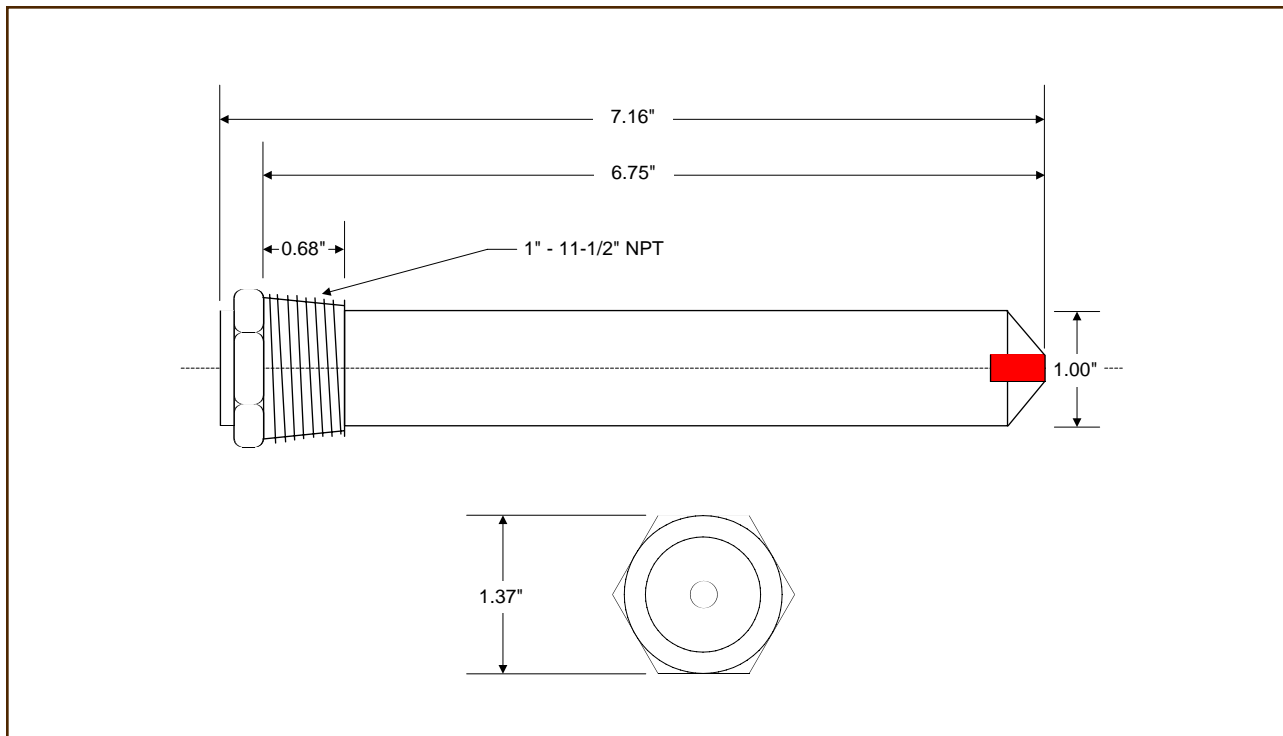

OPERATION The HLG-1065 liquid level gauge can be mounted in the side or the top of the tank . Multiple liquid level gauges are applied when the desired liquid level indication exceeds the span of a single liquid level gauge.

Transformer oil is usually colorless and difficult to see without the aid of a liquid level gauge. The HLG-1065 uses a crystal clear optical rod and ambient light to provide positive indication of the oil level. The rod has a prismatic cone at the tip with a red indicator in the center of the cone. When the oil level is above the cone, the gauge window is black. When the oil level is below the cone, the gauge window is red. The gauge window will indicate black or red, regardless of the oil color or the incident of light falling on the gauge window.

SOLUTIONS Heartland personnel have been assisting customers with transformer control and instrumentation applications since 1970. We invite you to contact our customer service professionals with your requirements. Heartland is the source for quality products, fast service and dependable support. The next time your application requires a liquid level gauge, order the HLG-1065 from the solutions company, Heartland Solutions.

The Heartland HLG family of liquid level gauges includes other models for a variety of spans and applications. For information on other models in the HLG liquid level gauge family or other fine Heartland products for electrical equipment, please phone, fax or E-mail Heartland Solutions.

 **Heartland Products Division**

Heartland Solutions, Inc.
630 Brooker Creek Blvd.
Suite 345
Oldsmar, FL 34677

Phone: 800.957.3493
Fax: 877.779.4567
Internet: info@hland.com