

Surge Arresters

**VariSTAR® Type AZG2 Surge Arresters
for Systems through 220 kV
IEC 10-kA; Line Discharge Class 2**

**Electrical Apparatus
1235-82**

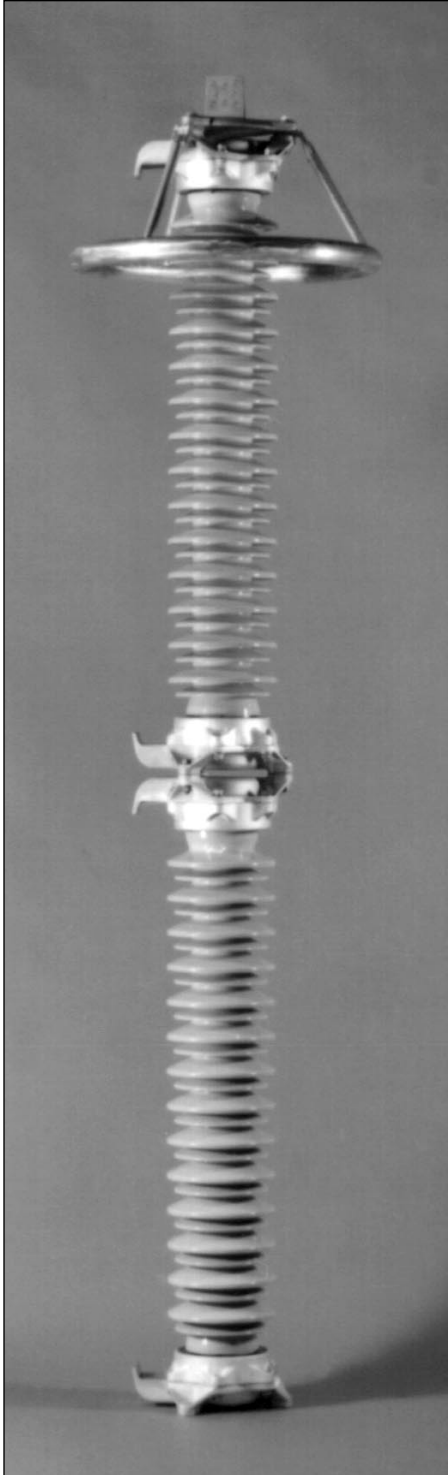

Figure 1.
VariSTAR Type AZG2
Surge Arrester, $U_r = 240$ kV.

GENERAL

VariSTAR® AZG2 Surge Arresters offer the latest in metal oxide varistor (MOV) technology for the economical protection of medium-voltage class power and substation equipment. These arresters are gapless and are constructed of a single series column of 49 mm diameter MOV disks. The arrester is designed and tested exclusively to the requirements of the International Electrotechnical Commission Standard IEC 99-4, and is available in ratings suitable for the transient overvoltage protection of electrical equipment on systems through 220 kV.

Cooper Power Systems assures the design integrity of the AZG2 arrester through a rigorous testing program conducted at the Thomas A. Edison Technical Center and at the factory in Olean, NY USA. The availability of complete "in-house" testing facilities assures that as continuous process improvements are made, they are professionally validated to the highest technical standards.

Our Quality Program is registered in conformance with ISO 9001.

CONSTRUCTION

External

The wet-process porcelain housing features an alternating shed design ($U_r > 48$ kV) that provides excellent resistance to the effects of atmospheric housing contamination. AZG2 arresters are optionally available with extra creepage porcelains for use in areas

with extreme conditions of natural and man-made atmospheric pollution.

The dielectric properties of the porcelain are coordinated with the electrical protective characteristics of the arrester in accordance with the requirements of IEC 99-4. (See Table 3.) The unit end castings are of a corrosion-resistant aluminum alloy configured for interchangeable mounting with many manufacturers' arresters for ease in upgrading to VariSTAR Arrester Technology. This three-footed mounting is provided on a 111 to 127 mm radius pattern for customer supplied 12 mm diameter hardware. High cantilever strength assures mechanical integrity.

Housings are available in standard grey or optional brown glaze color.

Standard line and earth terminal connectors accommodate up to 335 mm² conductor. Insulating bases and discharge counters are optionally available for in-service monitoring of arrester discharge activity.

The end fittings and porcelain housing of each arrester unit are sealed and tested by means of a sensitive helium mass spectrometer; this assures that the quality and insulation protection provided by the arrester is never compromised over its lifetime by the entrance of moisture. A corrosion-resistant nameplate is provided and contains all information required by IEC Standards; in addition, stacking arrangement information is provided for multi-unit arresters. Voltage grading rings are included for arresters rated 132 kV and above.

TABLE 1

System Application Voltages	3-220 kV
Rated Arrester Voltages, U_r	3-240 kV
Power System Frequency	50 or 60 Hz
Applicable Design and Test Standard	IEC 99-4
Nominal Discharge Current	10 kA
Line Discharge Class	2
High Current Withstand	100 kA
Pressure Relief Class	40 kA rms sym
Rated Discharge Energy	3.4 kJ/kV of U_c or 2.7 kJ/kV of U_r

Features and Detailed Description

Internal

The VariSTAR AZG2 Arrester's design reliability is enhanced by its totally gapless design. Gapless construction makes a significant contribution to the performance of arresters through the elimination of gap reseal as a consideration associated with the discharge of switching surge currents. The specially formulated metal-oxide varistors, manufactured under Cooper Power Systems exclusive quality control, provide exceptional non-linear protective characteristics, durability, and dependable energy dissipation capabilities.

OPERATION

The VariSTAR AZG2 Arrester conducts only a few milliamperes of leakage current when energized at normal system voltage. When an overvoltage event occurs, the arrester conducts only the current and consequently the energy necessary to limit the overvoltage to its protective level. By doing so it provides precise and predictable protection, minimizes the absorbed energy, and discharges no power frequency system currents.

VariSTAR Arresters are ideal for the protection of critical substation apparatus in areas of moderate lightning incidence and for protection against switching surges generated on transmission systems.

In the unlikely event of an arrester failure, a directed pressure relief system is incorporated in the VariSTAR AZG2 Arrester Design. A directed pressure venting system rapidly relieves internal pressure and transfers the internal arc to the outside of the arrester porcelain through vent ports in the end castings.

When called upon to operate, this mechanism vents internal pressures in fractions of a cycle, simultaneously transferring the fault current arc to the outside, preventing violent arrester failure. This mechanism is effective for system fault currents up to 40,000 amperes rms symmetrical (104,000 A first crest).

GENERAL APPLICATION RECOMMENDATIONS

The rating of an arrester is the power-frequency line-to-earth voltage at which the arrester is designed to pass the IEC 99-4 operating duty test. Table 2 provides a general guide for the selection of the proper arrester for a given system voltage.

Cooper Power Systems application engineers are available to make specific system application recommendations.

Selection of Arrester Rating

In arrester rating selection it is preferable to determine the lowest arrester rating that will ensure satisfactory operation. This is the optimum solution because the arrester selected will not only provide the greatest margin of insulation protection but also be the most economical choice.

Increasing arrester ratings above the minimum increases the likelihood of arrester survival during potential system contingencies but compromises the protection of equipment insulation. Table 2 lists VariSTAR AZG2 Arrester Ratings commonly used on various 3-phase systems.

Rating selection should begin with consideration of the maximum system operating voltage. The maximum

power frequency voltage expected under normal system conditions (expressed line-to-earth) should not exceed the selected arrester's continuous operating voltage (U_c).

The temporary overvoltage (TOV) capability of the VariSTAR AZG2 Arrester is shown in Figure 3. The curves indicate the arrester's ability to withstand abnormal system power frequency (sinusoidal) overvoltages for various durations. The values shown assume that the arrester has been energized at COV (U_c) prior to an overvoltage event, that the arrester is in an ambient temperature of 60 degrees celsius, and that after the overvoltage durations shown, demonstrate that the arrester will thermally recover when once again energized at COV (U_c).

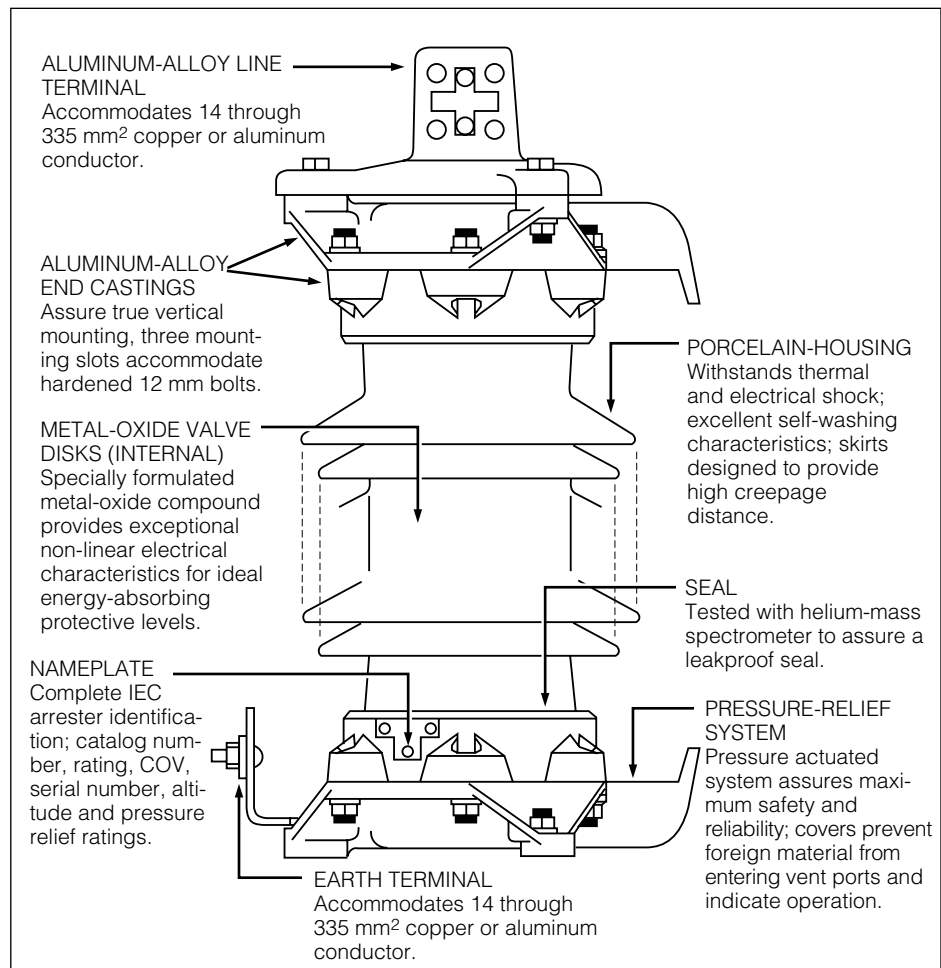

Figure 2. VariSTAR Type AZG2 Arrester Construction Details.

It is not recommended that the TOV curve be extended for periods in excess of 10,000 seconds (2.8 hrs).

For ungrounded systems, systems utilizing high impedance or resonant grounding and other systems where the line-to-earth voltage may be elevated to line-to-line voltages for extended periods, arresters having a COV (U_c) equal to line-to-line voltage may be required.

For non-sinusoidal transient voltages caused by system switching operations, a transient network analyzer (TNA) study is recommended; Cooper Power Systems engineers are available to make these studies.

Figure 3 also illustrates the arrester's TOV capabilities with and without prior switching surge duties of up to a maximum capability of 3.4 kJ/kV of COV (U_c).

To assure proper application, the following information is normally required:

1. Maximum system operating voltage.
2. System grounding conditions.

A. For four-wire circuits, grounding conditions depend upon whether the system is multi-grounded, whether it has neutral impedance, and whether common primary and secondary neutrals are used.

TABLE 2
Arrester Ratings Commonly Used on 3-Phase Systems

System Voltages L-L (kV)		Arrester Ratings (kV)	
Nominal	Max	Grounded Circuits	High-Impedance/ Ungrounded Circuits
3.3	3.7	3	-
6.6	7.3	6	9
10.0	11.5	9	12-15
11.0	12.0	9-10	12-15
16.4	18.0	15	18-21
22.0	24.0	18-21	24-27
33.0	36.3	27-30	36-45
47.0	52.0	39-48	54-60
66.0	72.0	54-60	66-84
91.0	100	78-84	90-96
110	123	96-108	120-138
132	145	108-120	132-144
155	170	132-144	162-172
220	245	180-198	204-240

B. For three-wire circuits, grounding conditions depend upon whether the system is solidly grounded at the source, grounded through neutral impedance at the source, grounded through transformers, or ungrounded.

Where unusual conditions exist (high ground resistance, high capacitive load, unusual switching surge duty, etc.), the following supplementary information is required:

1. Type of unusual condition.

2. BIL of equipment and separation distance to protected equipment.

3. Type of construction (phase spacing, length of line, conductor size, etc.).

4. Grounding and phase-sequence components of source impedances.

5. Phase-sequence components of load impedances.

6. Available fault current.

7. Potential for loss of neutral earthing during system events.

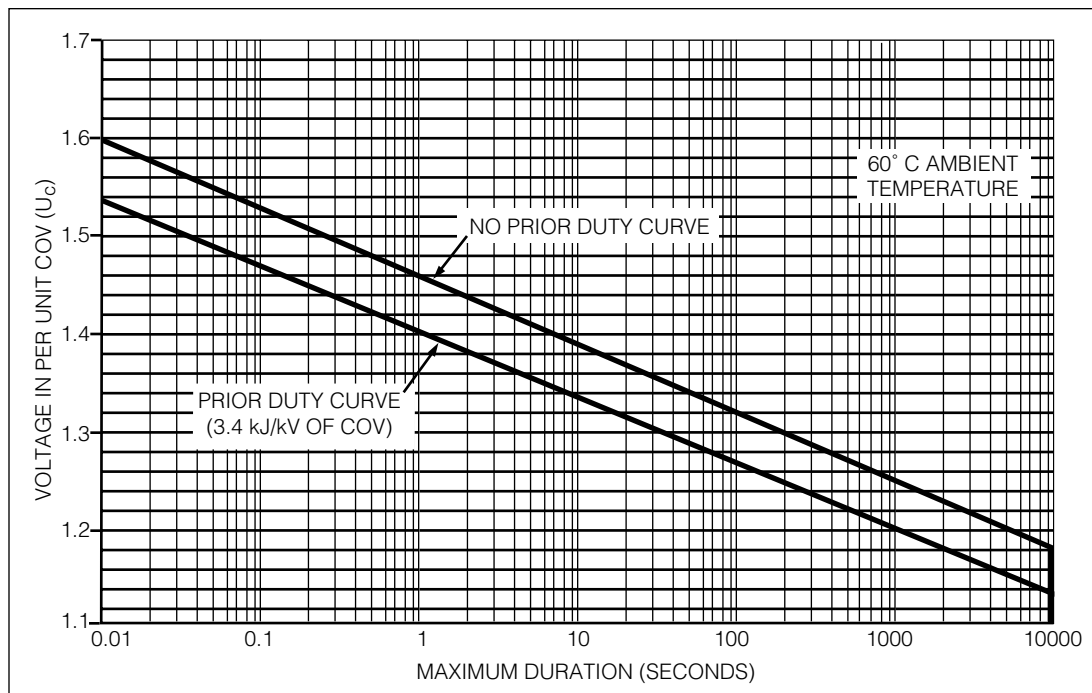

Figure 3.
Temporary overvoltage capability of VariSTAR AZG2 Surge Arresters.

VariSTAR® Type AZG2 Surge Arresters

PERFORMANCE AND PROTECTIVE CHARACTERISTICS

Table 4, “Residual Voltages – Maximum Guaranteed Protective Characteristics For Type AZG2 Surge Arresters” displays the Arrester Rating (U_r), Continuous Operating Voltage (U_c) and the guaranteed protective characteristics.

The Steep Current Impulse protective level is the maximum residual voltage for an impulse current of specified magnitude rising to crest in one microsecond. Lightning Impulse Residual Voltages represent the maximum protective levels exhibited by the arrester when discharging lightning currents of the standard 8/20 microsecond waveshape. The maximum Switching Impulse Residual Voltages are based on a switching surge current having a time to crest of 30 microseconds. For all ratings the switching surge energy absorption capability is 3.4 kJ/kV of COV (U_c).

ROUTINE TESTS

A complete production test program assures the quality of every VariSTAR AZG2 Surge Arrester. Each completed arrester is required to satisfactorily pass the following test regimen conducted in accordance with the procedures established in IEC 99-4:

- Partial Discharge Test at 1.05 times U_c .
- Reference Voltage Test (U_{ref}), voltage measured at reference current.
- Leakage current is measured at U_c and U_r .
- Residual Voltage Test.
- Sealing Effectiveness Test of Housing by helium mass spectrometer.

STANDARDS

The VariSTAR AZG2 Surge Arrester has been tested and certified to IEC Standard 99-4. Guaranteed performance characteristics are specified in this catalog section and in the relevant “Design Certification Test Report”, Cooper Power Systems Bulletin 93039. A seismic test report may be requested.

TABLE 3
Type AZG2 Surge Arrester Housing Insulation Withstand Characteristics

Housing Designation*	Creepage Distance (mm)	Arcing Distance (mm)	BIL 1.2/50 wave (kV Pk)	Wet 50/60 Hz – 60s (kV, rms)	Switching Wet (kV Pk)
01	234	132	130	35	40
02	406	195	170	60	70
03	665	291	230	90	110
04	922	386	265	125	150
05	1267	513	320	165	200
06	1646	600	365	170	250
07	1875	672	385	195	300
08	2540	889	505	250	350
09	3226	1106	650	285	400
18	3518	1218	780	370	550
19	3744	1291	790	385	600
20	4186	1440	850	400	625
21	4412	1508	920	440	750
22	4872	1548	925	440	750
23	5098	1620	930	480	810
24	5766	1839	1065	530	915
25	6452	2055	1185	545	1015

* Housing designation is indicated in the 6th and 7th position of the catalog number.

TABLE 4
Residual Voltages – Maximum Guaranteed Protective Characteristics for Type AZG2 Surge Arresters

Arrester Rating U _r (kV, rms)	Arrester MCOV U _c (kV, rms)	Steep Current Residual Voltage (kV Crest)	Lightning Impulse Residual Voltage (kV Crest) 8/20 μs Current Wave						Switching Impulse Residual Voltage (kV Crest) 30/60 Current Wave	
			10 kA	1.5 kA	3 kA	5 kA	10 kA	20 kA	40 kA	125 A
3	2.55	12.5	7.1	7.5	7.9	8.6	9.8	11.8	6.2	6.6
6	5.10	22.0	14.2	15.0	15.7	17.0	19.1	22.3	12.4	13.2
9	7.65	31.4	21.2	22.4	23.5	25.5	28.4	32.8	18.6	19.8
10	8.4	34.2	23.3	24.6	25.8	27.9	31.1	35.9	20.4	21.8
12	10.2	40.8	28.3	29.8	31.3	33.9	37.7	43.4	24.8	26.5
15	12.7	50.1	35.2	37.2	39.0	42.1	46.8	53.7	30.9	32.9
18	15.3	59.7	42.5	44.7	46.9	50.7	56.3	64.4	37.2	39.7
21	17.0	66.0	47.2	49.7	52.1	56.3	62.5	71.4	41.3	44.1
24	19.5	75.3	54.1	57.0	59.8	64.6	71.6	81.7	47.4	50.5
27	22.0	84.5	61.0	64.3	67.4	72.8	80.7	92.0	53.5	57.0
30	24.4	93.4	67.7	71.3	74.8	80.7	89.5	102	59.3	63.2
33	27.5	105	76.3	80.4	84.2	91.0	101	115	66.9	71.3
36	29.0	111	80.4	84.8	88.8	95.9	106	121	70.5	75.2
39	31.5	120	87.4	92.1	96.5	104	115	131	76.6	81.6
42	34.0	129	94.3	99.4	104	112	125	142	82.7	88.1
45	36.5	138	101	107	112	121	134	152	88.8	94.6
48	39	148	108	114	119	129	143	162	94.9	101
54	42	159	117	123	129	139	154	175	102	109
60	48	181	133	140	147	159	176	199	117	124
66	53	199	147	155	162	175	194	220	129	137
72	57	214	158	167	175	188	209	236	139	148
78	62	233	172	181	190	205	227	257	151	161
84	68	255	189	199	208	225	249	282	165	176
90	70	262	194	205	214	231	256	290	170	181
96	76	285	211	222	233	251	278	315	185	197
108	84	314	233	245	257	277	307	348	204	218
120	98	366	272	286	300	324	358	406	238	254
132	106	399	294	310	325	350	388	440	258	275
138	111	417	308	324	340	367	406	461	270	288
144	115	432	319	336	352	380	421	477	280	298
162	130	488	360	380	398	429	475	539	316	337
168	131	491	363	383	401	433	479	543	319	339
172	140	525	388	409	429	462	512	580	341	363
180	144	539	399	421	441	476	526	597	350	373
192	152	569	421	444	465	502	556	630	370	394
198	160	599	444	467	490	528	585	663	389	415
204	165	617	457	482	505	545	603	683	401	428
216	174	650	482	508	533	575	636	720	423	451
228	182	680	505	532	557	601	665	753	443	472
240	190	710	527	555	581	627	694	786	462	492

DIMENSIONS AND MOUNTING

Figure 4 illustrates an in-line mounting arrangement; the applicable values of “C” and “D” may be found in Table 5. Line and earth terminal details are shown in Figure 5; the supplied terminals accommodate aluminum and copper conductors to a maximum size of 335 mm². For other conductors the terminal drilling pattern shown will accommodate industry standard two (2) and four (4) hole flat pad connectors. Figure 6 provides the dimensional details for universal base mounting.

The vent port in the base must be directed away from any adjacent equipment to control and prevent ionized gases from damaging other equipment in the unlikely event of arrester failure.

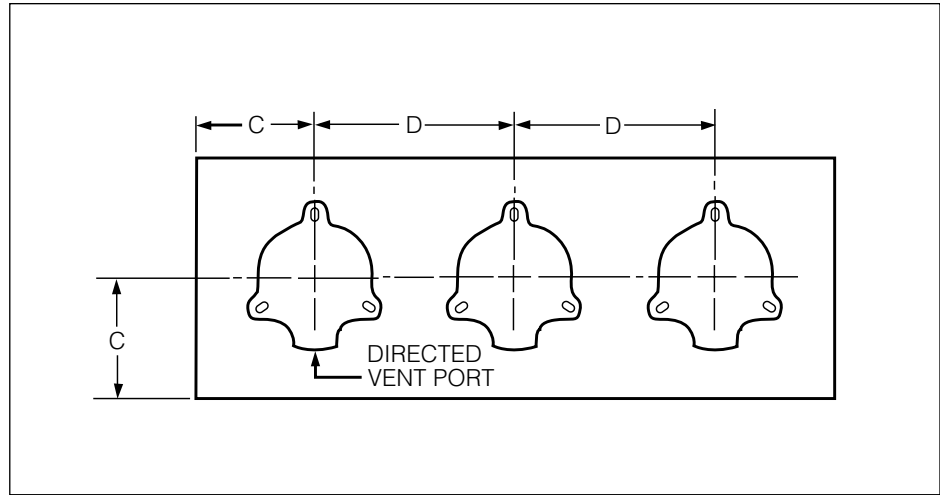

Figure 4.
Three-phase in-line mounting.

Note: Refer to Table 5 for dimensions C and D.

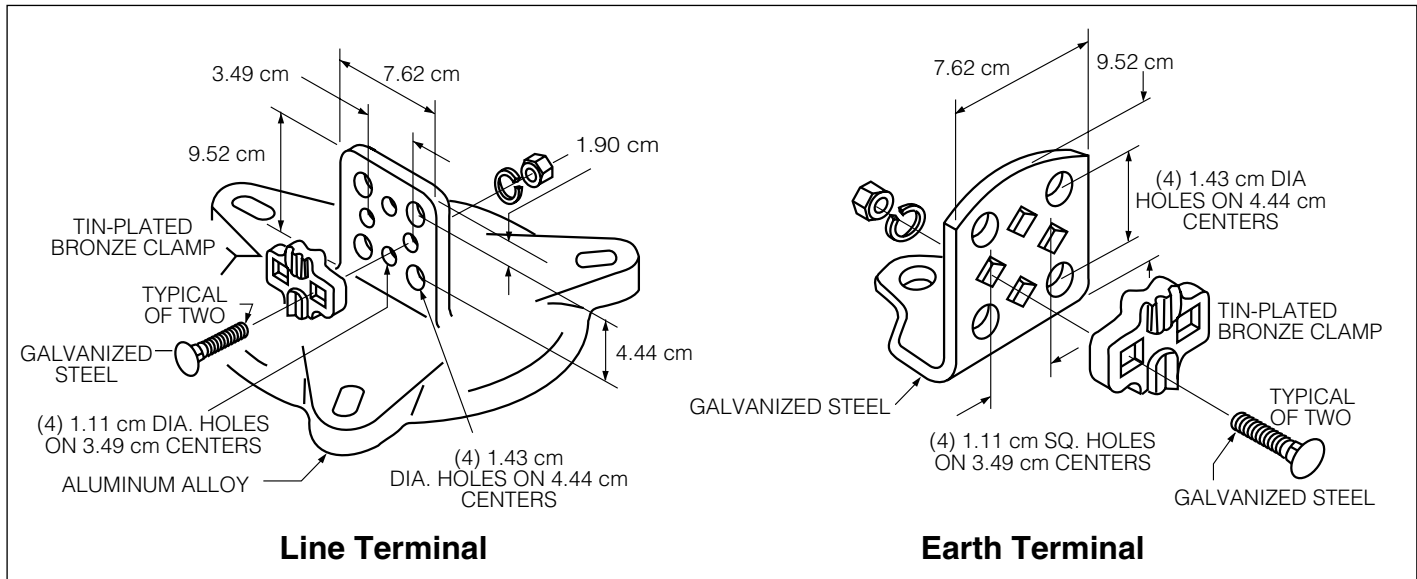

Figure 5.
Line and earth terminals (suitable for copper or aluminum conductors up to 335 mm²).

TABLE 5
Catalog Numbers and Dimensional Information (See Figures 4 & 8)

U _r Arrester Rating (kV, rms)	U _c Arrester COV (kV, rms)	Catalog Number	Dim. A (mm)	Figure 6 View Number	Dim. C Minimum Phase-to-Earth* Clearance (mm)	Dim. D Minimum Phase-to-Phase* Clearance (mm)	Housing Leakage Distance (mm)	Arrester Mass (kg)
3	2.55	AZG2001G002003	471	1	163	308	234	19
6	5.10	AZG2001G005006	471	1	167	312	234	19
9	7.65	AZG2001G007009	471	1	180	324	234	19
10	8.40	AZG2002G008010	535	1	185	329	406	22
12	10.2	AZG2002G010012	535	1	199	343	406	22
15	12.7	AZG2002G012015	535	1	222	367	406	22
18	15.3	AZG2003G015018	630	1	249	394	665	26
21	17.0	AZG2003G017021	630	1	268	412	665	26
24	19.5	AZG2003G019024	630	1	273	418	665	26
27	22.0	AZG2004G022027	725	1	298	443	922	30
30	24.4	AZG2004G024030	725	1	322	467	922	30
33	27.5	AZG2004G027033	725	1	354	498	922	30
36	29.0	AZG2004G029036	725	1	369	513	922	30
39	31.5	AZG2005G031039	852	1	393	538	1267	35
42	34.0	AZG2005G034042	852	1	418	562	1267	35
45	36.5	AZG2005G036045	852	1	445	590	1267	36
48	39.0	AZG2005G039048	852	1	470	614	1267	36
54	42.0	AZG2006G042054	929	1	500	645	1646	39
60	48.0	AZG2006G048060	929	1	561	706	1646	39
66	53.0	AZG2007G053066	1002	1	610	754	1872	44
72	57.0	AZG2007G057072	1002	1	649	794	1872	44
78	62.0	AZG2008G062078	1219	1	701	846	2540	53
84	68.0	AZG2008G068084	1219	1	762	907	2540	53
90	70.0	AZG2008G070090	1219	1	781	925	2540	53
96	76.0	AZG2008G076096	1219	1	842	986	2540	54
108	84.0	AZG2009G084108	1436	1	921	1065	3226	73
120	98.0	AZG2009G098120	1436	1	1064	1209	3226	74
132	106	AZG2018G106132	1827	2	1329	1659	3518	85
138	111	AZG2018G111138	1827	2	1381	1711	3518	86
144	115	AZG2019G115144	1898	2	1420	1751	3744	90
162	130	AZG2020G130162	2044	2	1570	1900	4186	96
168	131	AZG2021G131168	2116	2	1582	1912	4412	99
172	140	AZG2021G140172	2116	2	1670	2001	4412	100
180	144	AZG2022G144180	2261	3	1713	2043	4872	115
192	152	AZG2022G152192	2261	3	1792	2122	4872	116
198	160	AZG2023G160198	2333	3	1871	2202	5098	120
204	165	AZG2024G165204	2550	3	1923	2253	5766	129
216	174	AZG2024G174216	2550	3	2015	2345	5766	130
228	182	AZG2025G182228	2768	3	2094	2424	6452	149
240	190	AZG2025G190240	2768	3	2173	2503	6452	149

Notes:

1. Position #5 designates special nameplate options:

- 0-English
- 1-Spanish – American
- 2-Portuguese – Brazil
- 3-Portuguese – Portugal
- 4-Spanish – Spain (Castilian)

2. All arresters are available in grey (standard) or brown porcelain glaze. For brown glaze, substitute “B” for “G” in the eighth position of the catalog number.

3. Digit 6 & 7 housing designation, may be modified for arresters requiring creepage distance other than the standard arresters shown.

4. Cantilever strength for all ratings is 10,200 NM. Maximum working load should not exceed 40% of this value.

5. Refer to Figure 4 for illustration of dimensions C and D and Figure 8 for dimension A.

* Phase-to-Phase clearances are expressed as minimum arrester center-to-center distances. Phase-to-Earth clearances are expressed as minimum arrester centerline-to-earth distances.

VariSTAR® AZG2 Surge Arresters

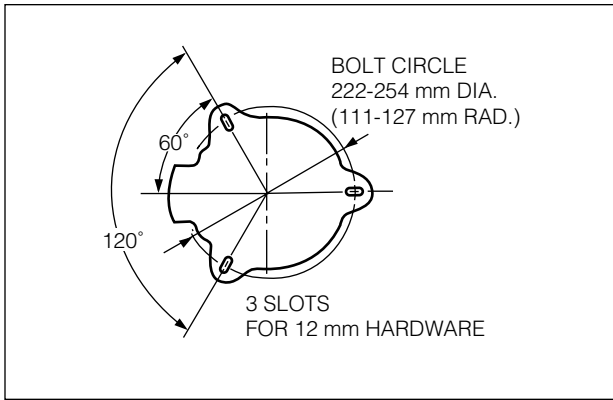

Figure 6.
Base mounting.

Note: To develop rated cantilever strength use 254 mm bolt circle mounting diameter and hardened bolts.

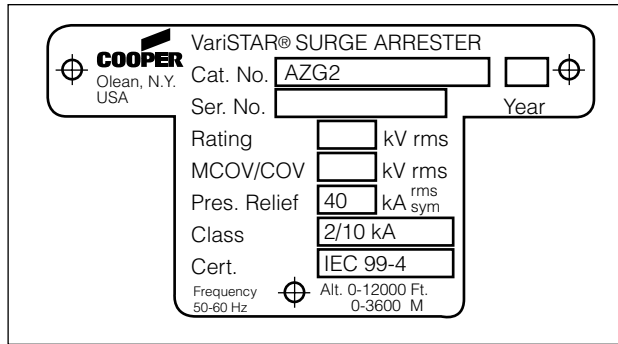

Figure 7.
Arrester Nameplate.

Note: Refer to Figure 2.

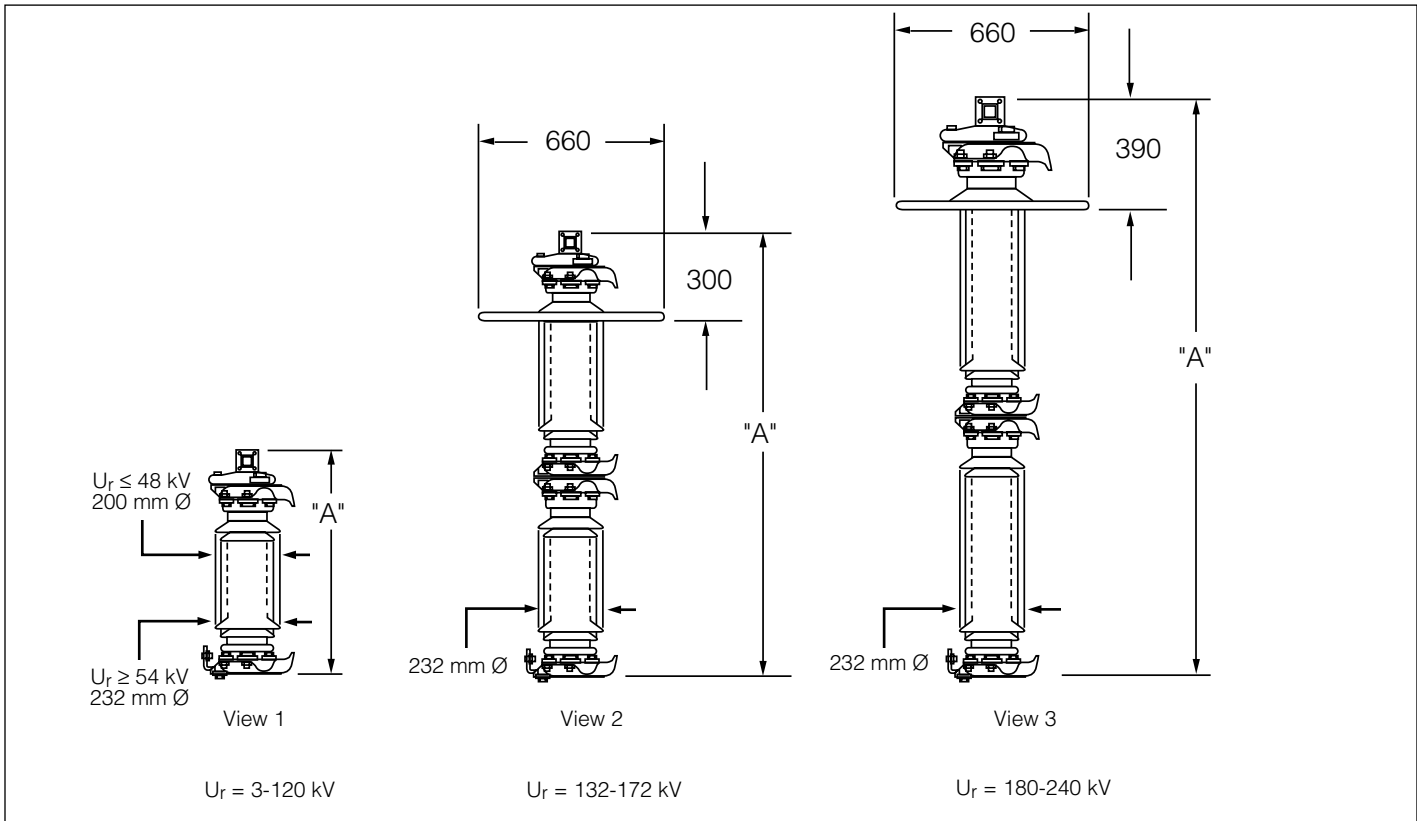

Figure 8.
Outlines of VariSTAR AZG2 Surge Arresters.

Note: Refer to Table 5 for dimension A.

