

Surge Arresters

**UltraSIL Polymer-Housed VariSTAR Type U4
Surge Arrester for Systems through 275 kV IEC
20 kA; Line Discharge Class 4**

Electrical Apparatus
1235-94

GENERAL

UltraSIL™ Polymer-Housed VariSTAR™ U4 Surge Arresters offer the latest in metal oxide varistor (MOV) technology for the economical protection of high voltage class power and substation equipment. These arresters are gapless and are constructed of a single series column of 76 mm diameter MOV disks. The arrester is designed and tested to the requirements of the International Electrotechnical Commission Standard IEC 60099-4 (IEC 99-4), and is available in ratings suitable for the transient overvoltage protection of electrical equipment on systems through 275 kV.

The UltraSIL Polymer-Housed U4 Surge Arrester incorporates the industry recognized superior polymeric material – Silicone Rubber.

The advantages of polymer housed arresters – reduced size and weight and enhanced safety – have been refined in this next generation of surge arresters: the UltraSIL Polymer-Housed U4 Surge Arrester from Cooper Power Systems.

**TABLE 1
UltraSIL Housed Type U4 Class 4
Ratings and Characteristics**

Arrester Characteristic	Rating	
Arrester Voltage Ratings, U_r	3-240 kV	
Rated Discharge Energy	Single Impulse	Double Impulse*
	kJ/kV of U_c	8.9 12.7
	kJ/kV of U_r	7.2 10.2
System Frequency (Hz)	50/60	
Classifying Current (kA)	20	
High Current Withstand** (kA)	100	
Pressure Relief Rating (kA rms sym.)	63	
Cantilever Strength (Nm)	Ultimate	MPSL (Static)***
	4,050	1,600

* Double impulse rating assumes a two shot energy discharge within one minute.
 ** High current, short duration withstand (100 kA, 4/10 μ s)
 *** MPSL -Maximum permissible service load (static) or maximum working load is 40% of the ultimate.



Figure 1.
UltraSIL Polymer-Housed VariSTAR Class 4 Surge Arrester family.

CONSTRUCTION

The unique construction of UltraSIL Housed Class 4 Arresters begins with world class Metal Oxide Varistor (MOV) disks produced at our dedicated manufacturing facility in Olean, NY. By manufacturing our own disks we maintain a strict quality control over the entire production process, from initial raw material inspection to final physical and electrical testing of each disk. In addition, by controlling the manufacturing process of both disks and arresters, we achieve the optimal combination. Cooper Power Systems produces MOV disks of unsurpassed quality through continuous

improvements in disk formulation and manufacturing technology. The end result is a long history of in-service use with outstanding durability and protective capability.

Arrester production begins by stacking glass-collared MOV disks in series with aluminum end electrodes. Our proprietary process wraps the assembly with a high-strength woven fiberglass-reinforced epoxy composite. When cured, the arrester module is capable of withstanding extreme electrical and cantilever load conditions.

The UltraSIL silicone rubber housing utilizes an interference fit and is bonded

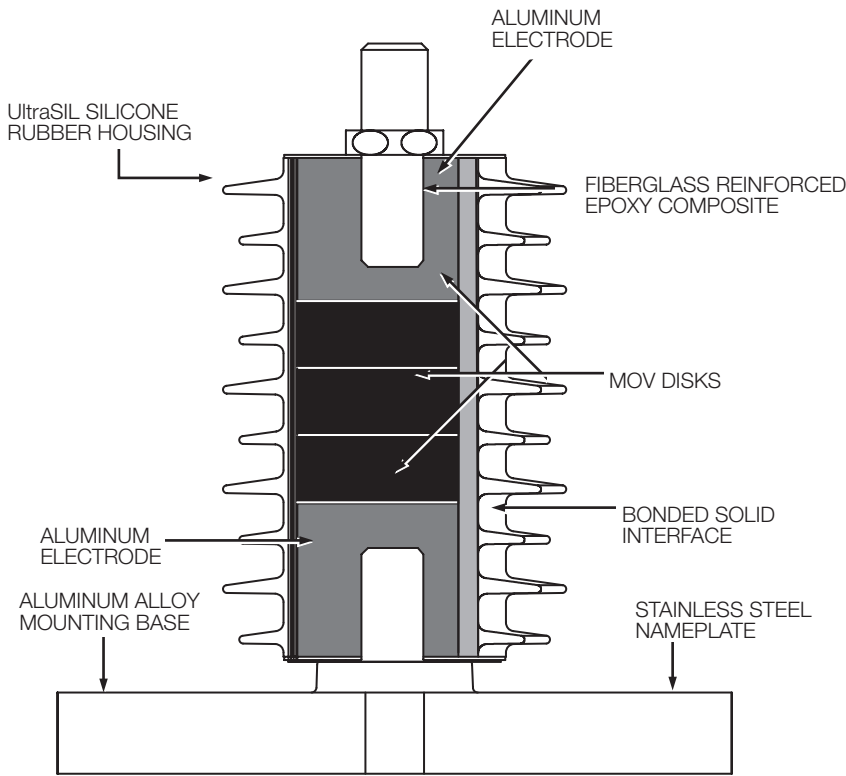

Figure 2. Cutaway illustration of UltraSIL Polymer-Housed VariSTAR Class 4 Arrester.

onto the internal module to form a solid, void-free, high-dielectric strength insulation system. Once the housing is in place, each arrester must pass a strict series of electrical tests to insure the highest level of in-service performance.

The silicone rubber housing results in lighter weight than similarly rated porcelain housed arresters. The silicone rubber housing is also less sensitive to physical damage than porcelain. Also, when compared to other polymeric housing materials, silicone rubber generates significantly lower external power losses under contaminated conditions.

FEATURES

The UltraSIL silicone rubber housing was chosen for its superior insulation performance when compared to other polymeric housing materials. Long term environmental testing has verified the superiority of UltraSIL silicone rubber when compared to other polymeric insulating materials.

Independent laboratory tests have verified the superior water repellent behavior of silicone rubber, which is responsible for the lower external power losses, higher resistance to UV degradation and surface tracking,

superior performance in contaminated environments, and other important insulating properties. Also, UltraSIL silicone rubber has been proven not to support biological growth and is non-flammable.

The basic silicone rubber housed arrester can be customized with a variety of terminal and mounting options which allow users to select the features that meet their application needs. Customers who require longer creepage housings can easily select a different housing option through the catalog numbering system. See pages 7 to 9 for a complete list of available options.

OPERATION

The operation of the VariSTAR arrester is typical of gapless metal oxide arresters. During steady state conditions, line-to-earth voltage is continuously across the arrester terminals. When overvoltages occur, the VariSTAR arrester immediately limits the overvoltage to the required protective level by conducting only the necessary level of surge current to earth. Upon passage of the overvoltage condition, the arrester returns to its initial condition, once again conducting only minimal leakage current.

UltraSIL polymer-housed VariSTAR Class 4 arresters are ideal for the protection of critical substation apparatus in areas of moderate lightning incidence and for protection against switching surges generated on transmission systems.

Pressure relief tests have been conducted in accordance with IEC 60099-4 to demonstrate the UltraSIL Polymer-Housed VariSTAR Class 4 Arrester’s ability to withstand fault currents for specific durations.

DESIGN TESTING

The housing material, internal components and hardware work as a system and stand up to years of exposure to environmental extremes. To assure a superior level of performance, the components and the assembled arrester unit have been subjected to a testing program that accurately simulates years of exposure to field conditions. Tests include:

IEC 60099-4 Testing – Full Certification to performance requirements by an independent laboratory has been completed. A certified test report is available upon request.

Additional design verification of the UltraSIL Polymer-Housed VariSTAR Class 4 Arrester includes testing for:

- Ultraviolet Withstand
- High Voltage Dielectric Integrity
- Wet Arc Tracking Resistance
- Thermal Shock
- Coefficients of Expansion and Materials Compatibility
- Cantilever Strength
- Terminal Torque

For detailed reports, please contact your Cooper Power Systems sales representative.

ROUTINE TESTS

A complete automated production test program ensures a quality product. Each metal oxide varistor receives a series of electrical tests. Quality is further demonstrated by tests performed to destruction on samples from every batch of varistors.

Routine tests on the varistor disks performed in accordance with IEC 60099-4:

- Physical Inspection
- Residual Voltage Test
- V_{ref} at 6 mA

- Watts Loss at $1.05 \times U_c$
Measured at Ambient Temperature.
 - Transmission Line Discharge Energy Test
 - Batch High Current, Short Duration
 - Batch Thermal Stability Test
 - Batch Aging Test
- Routine tests on each fully assembled UltraSIL VariSTAR Class 4 arrester, per IEC 60099-4:
- Physical Inspection
 - Partial Discharge Test
 - Reference Voltage Test
 - Watts Loss Test

GENERAL APPLICATION RECOMMENDATIONS

The rating of an arrester is the maximum power-frequency line-to-earth voltage at which the arrester is designed to pass the IEC operating duty test. Table 2 provides a general guide for the selection of the proper arrester for a given system voltage. Cooper Power Systems application engineers are available to make specific system application recommendations.

SELECTION OF ARRESTER RATING

In arrester rating selection it is preferable to determine the lowest arrester rating that will ensure satisfactory operation. This is the optimum solution because the arrester selected will not only provide the greatest margin of insulation protection but also be the most economical choice.

Increasing arrester ratings above the minimum increases the likelihood of arrester survival during potential system contingencies but compromises the protection of equipment insulation. Table 2 lists VariSTAR U4 arrester ratings commonly used on various 3-phase systems.

Rating selection should begin with consideration of the maximum system operating voltage. The maximum power frequency voltage expected under normal system conditions (expressed line-to-earth) should not exceed the selected arrester's continuous operating voltage (U_c).

The temporary overvoltage (TOV) capability of the VariSTAR U4 arrester is shown in Figure 3. The curves indicate the arrester's ability to withstand abnormal system power

TABLE 2
Arrester Ratings Commonly Used on 3-Phase Systems

System Voltages L-L (kV)		Arrester Ratings (kV)	
Nominal	Maximum	Grounded Circuits	High Impedance/ Ungrounded Circuits
3.3	3.7	3	6
6.6	7.3	6	9
10.0	11.5	9	12-15
11.0	12.0	9-10	12-15
16.4	18.0	15.0	18-21
22.0	24.0	18-21	24-27
33.0	36.3	27-30	36-39
47.0	52.0	39-48	54-60
66.0	72.0	54-60	66-84
91.0	100	78-84	90-96
110	123	96-108	120-138
132	145	108-120	132-144
155	170	132-144	162-172
220	245	180-198	204-240
275	300	216-240	-

frequency (sinusoidal) overvoltages for various durations. The values shown assume that the arrester has been energized at COV (U_c) prior to an overvoltage event, that the arrester is in an ambient temperature of 60°C , and that after the overvoltage durations shown, demonstrate that the arrester will thermally recover when once again energized at COV (U_c).

The voltage withstand capability for application on ungrounded systems after IEC high current duty is 1.07 per unit of COV (U_c) for 24 hours. For ungrounded systems, systems utilizing high impedance or resonant grounding and other systems where the line-to-earth voltages exceed this stated TOV capability, arresters having a COV (U_c) equal to line-to-line voltage may be required.

For non-sinusoidal transient voltages

caused by system switching operations a transient network analyzer (TNA) study is recommended; Cooper Power Systems engineers are available to make these studies.

Figure 3 also illustrates the arrester's TOV capabilities with and without prior switching surge duties of up to a maximum capability of 8.9 kJ/kV of COV (U_c)-single impulse and 12.7 kJ/kV of COV (U_c)-double impulse.

To assure proper application the following information is normally required:

1. Maximum system operating voltage.
2. System grounding conditions.
 - A. For four-wire circuits, grounding conditions depend upon whether the system is multi-grounded, whether it has

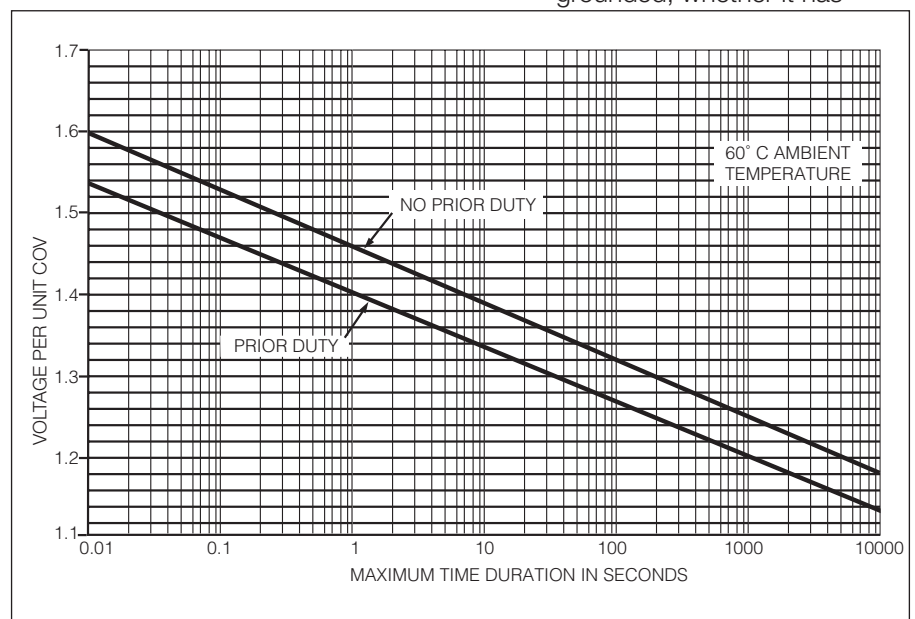

Figure 3.
Temporary Overvoltage Capability of VariSTAR U3 Surge Arresters.

Note: The 24 hour TOV with prior duty is 1.07 per unit of U_c .

neutral impedance, and whether common primary and secondary neutrals are used.

- B. For three-wire circuits, grounding conditions depend upon whether the system is solidly grounded at the source, grounded through the neutral impedance at the source, grounded through transformers, or ungrounded.

Where unusual conditions exist (high ground resistance, high capacitive load, unusual switching surge duty, etc.), the following supplementary information is required:

- Type of unusual condition.
- BIL of equipment and separation distance to protected equipment.
- Type of construction (phase spacing, length of line, conductor size, etc.).
- Grounding and phase-sequence components of source impedances.
- Phase-sequence components of load impedances.
- Available fault current.
- Potential for loss of neutral earthing during system events.

PERFORMANCE AND PROTECTIVE CHARACTERISTICS

Table 4, "Protective Characteristics of the UltraSIL Polymer-Housed VariSTAR U4 Surge Arrester" displays the Arrester Rating (U_R), Continuous Operating Voltage (U_C) and the guaranteed protective characteristics.

The Steep Current Impulse protective level is the maximum residual voltage for a 10 kA impulse current that crests in one microsecond. Lightning Impulse Residual Voltages represent the maximum protective levels exhibited by the arrester when discharging lightning currents of the standard 8/20 microsecond waveshape. The maximum Switching Impulse Residual Voltages are based on a switching surge current having a time to crest of 30 microseconds. For all ratings the switching surge energy absorption capability is 8.9 kJ/kV of U_C -single impulse and 12.7 kJ/kV of U_C -double impulse.

TABLE 3
Insulation Withstand Voltages

Housing Designation	Housing Leakage Distance (mm)	Strike (mm)	Insulation Withstand Voltages		
			BIL 1.2/50 Impulse (kV, Pk)	Switching Surge Impulse (kV, crest)	Wet 50/60 Hz 60 Sec (kV, rms)
8	487	198	130	0	53
10	609	237	140	0	65
12	730	277	171	0	77
14	852	316	193	0	89
16	974	355	214	0	101
18	1095	395	236	0	113
20	1217	434	255	0	121
22	1339	474	279	0	137
24	1460	513	301	0	149
26	1582	553	322	0	161
28	1704	592	344	0	173
30	1826	632	366	0	185
36	2191	787	472	0	226
38	2312	827	491	0	234
40	2434	866	510	0	242
42	2556	906	534	0	258
44	2677	945	558	0	274
46	2799	984	580	0	286
48	2921	1024	602	0	298
50	3043	1063	623	0	310
52	3164	1103	644	0	322
54	3286	1142	666	0	334
56	3408	1182	688	0	346
58	3529	1221	710	0	358
60	3651	1260	732	0	370
62	3773	1182	706	0	350
64	3894	1221	730	0	366
66	4016	1240	754	0	382
68	4138	1279	776	0	394
70	4260	1319	798	0	406
72	4381	1341	821	0	417
74	4503	1381	842	0	429
76	4625	1420	863	0	441
78	4746	1445	890	0	453
80	4868	1485	912	0	465
82	4990	1524	934	0	477
84	5111	1552	957	0	488
86	5233	1591	979	0	500
88	5355	1631	1001	0	512
90	5477	1660	1029	960	521
92	5598	1790	1077	1038	543
94	5720	1829	1099	1059	555
96	5842	1852	1122	1082	566
98	5963	1891	1143	1103	578
A0	6085	1931	1164	1124	590
A2	6207	1970	1185	1145	602
A4	6328	1996	1212	1166	614
A6	6450	2035	1234	1187	626
A8	6572	2074	1256	1208	638
B0	6694	2114	1278	1229	650
B2	6815	2142	1301	1244	661
B4	6937	2181	1323	1265	673
B6	7059	2220	1345	1286	685
B8	7180	2260	1367	1307	697
C0	7302	2289	1395	1314	706

TABLE 4
Protective Characteristics of the UltraSIL Polymer-Housed VariSTAR U4 Surge Arrester

Arrester Rating U_r (kV, rms)	Arrester COV U_c (kV, rms)	Steep Current Residual Voltage (kV Crest)	Lightning Impulse Residual Voltage (kV Crest) 8/20 μ s Current Wave						Switching Impulse Residual Voltage (kV Crest) 30/60 Current Wave			
			1.5 kA	3 kA	5 kA	10 kA	20 kA	40 kA	250 A	500 A	1000 A	2000 A
3	2.55	8.3	6.4	6.7	7.0	7.5	8.3	9.7	5.9	6.0	6.3	6.6
6	5.10	16.3	12.8	13.4	13.9	14.9	16.4	18.7	11.7	12.0	12.5	13.0
9	7.65	24.1	19.3	20.1	20.8	22.2	24.4	27.7	17.6	18.0	18.7	19.5
10	8.40	26.4	21.1	22.1	22.9	24.4	26.8	30.3	19.3	19.8	20.5	21.4
12	10.2	32.0	25.7	26.8	27.8	29.6	32.5	36.6	23.4	24.1	24.9	25.9
15	12.7	39.7	32.0	33.4	34.6	36.8	40.4	45.5	29.1	29.9	31.0	32.3
18	15.3	47.8	38.5	40.2	41.6	44.4	48.6	54.6	35.1	36.1	37.4	38.8
21	17.0	53.1	42.8	44.7	46.2	49.3	54.0	60.6	39.0	40.1	41.5	43.1
24	19.5	60.9	49.1	51.2	53.0	56.5	61.9	69.5	44.8	46.0	47.6	49.5
27	22.0	68.5	55.3	57.8	59.8	63.7	69.9	78.3	50.5	51.9	53.7	55.8
30	24.4	76.0	61.4	64.1	66.4	70.7	77.5	86.7	56.0	57.5	59.6	61.9
33	27.5	85.6	69.2	72.2	74.8	79.6	87.3	97.7	63.1	64.8	67.1	69.7
36	29.0	90.3	72.9	76.2	78.9	84.0	92.0	103	66.6	68.4	70.8	73.5
39	31.5	97.9	79.2	82.7	85.6	91.2	100	112	72.3	74.2	76.9	79.9
42	34.0	106	85.5	89.3	92.4	98.4	108	121	78.0	80.1	83.0	86.2
45	36.5	114	91.8	95.8	99.2	106	116	129	83.8	86.0	89.1	92.5
48	39.0	121	98.1	102	106	113	124	138	89.5	91.9	95.2	98.9
54	42.0	131	106	110	114	122	133	149	96.4	99.0	103	107
60	48.0	149	121	126	131	139	152	170	110	113	117	122
66	53.0	166	133	139	144	154	168	188	122	125	129	134
72	57.0	177	143	150	155	165	181	202	131	134	139	145
78	62.0	193	156	163	169	180	197	220	142	146	157	157
84	68.0	212	171	179	185	197	216	241	156	160	166	172
90	70.0	218	176	184	190	203	222	248	161	165	171	177
96	76.0	236	191	200	207	220	241	269	174	179	186	193
108	84.0	261	211	221	228	243	266	298	193	198	205	213
120	98.0	305	247	257	266	284	311	347	225	231	239	248
132	106	330	267	278	288	307	336	376	243	250	259	269
138	111	345	279	292	302	321	352	394	255	262	271	281
144	115	358	289	302	313	333	365	408	264	271	281	292
162	130	404	327	341	354	376	412	461	298	306	317	330
168	131	407	330	344	356	379	415	464	301	309	320	332
172	140	435	352	368	381	405	444	496	321	330	342	355
180	144	447	362	378	392	417	457	510	331	339	352	365
192	152	472	382	399	413	440	482	539	349	358	371	385
198	160	497	403	420	435	463	507	567	367	377	391	406
204	165	513	415	433	449	478	523	585	379	389	403	418
216	174	541	438	457	473	504	552	616	399	410	425	441
228	182	566	458	478	495	527	577	645	418	429	444	461
240	190	590	478	499	517	550	602	673	436	448	464	481

DIMENSIONS AND MOUNTING

Figure 4 illustrates an in-line mounting arrangement; the applicable values of "B" and "C" may be found in Table 5. Line and Earth terminal details are shown on Page 9, options 11 and 12. Figure 5 shows an outline drawing of the standard UltraSIL Polymer-Housed VariSTAR Class 4 Arrester. The values for Dimensions "A" and "D" for all ratings are listed in Table 5.

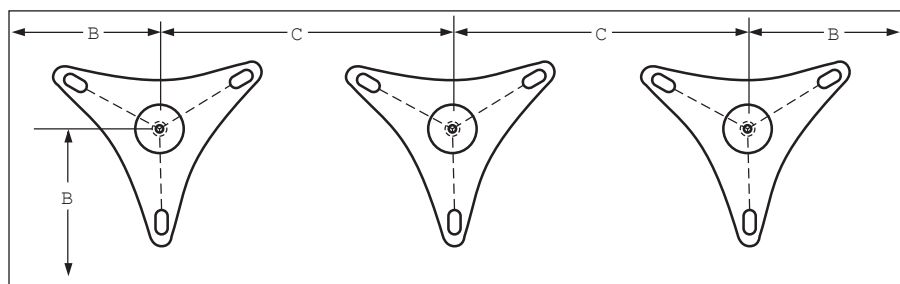

Figure 4.
Three-phase in-line mounting.

Note: Refer to Table 5 for Dimensions B and C.

TABLE 5
Catalog Numbers and Dimensional Information and Weights for VariSTAR U4 Surge Arresters

Arrester Rating U_r (kV, rms)	Arrester COV U_c (kV, rms)	Standard Arrester Catalog Number	Dim. A (mm) (Fig. 5)	Dimension B Minimum Phase-to-Earth Clearance* (mm) (Fig. 4)	Dimension C Minimum Phase-to-Phase Clearance* (mm) (Fig. 4)	Dim. D (mm) (Fig. 5)	Housing Leakage Distance** (mm)	Arrester Mass (kg)
3	2.55	U40030020845AAA	207	95	171	134	487	7.2
6	5.10	U40060051045AAA	246	97	173	134	609	8.3
9	7.65	U40090071045AAA	246	105	181	134	609	8.7
10	8.40	U40100081045AAA	246	108	184	134	609	8.7
12	10.2	U40120101245AAA	285	118	194	134	730	9.7
15	12.7	U40150121445AAA	324	135	211	134	852	10.8
18	15.3	U40180151445AAA	324	156	232	134	852	11.1
21	17.0	U40210171645AAA	364	153	230	134	974	11.8
24	19.5	U40240191845AAA	403	175	251	134	1095	12.9
27	22.0	U40270221845AAA	403	196	272	134	1095	13.2
30	24.4	U40300242045AAA	442	216	293	134	1217	14.3
33	27.5	U40330272245AAA	481	243	319	134	1339	15.4
36	29.0	U40360292245AAA	481	256	332	134	1339	15.4
39	31.5	U40390312245AAA	481	277	353	134	1339	15.7
42	34.0	U40420342445AAA	520	298	374	134	1460	16.7
45	36.5	U40450362645AAA	559	321	397	134	1582	17.8
48	39.0	U40480392645AAA	559	341	417	134	1582	18.2
54	42.0	U40540422845AAA	598	368	444	134	1704	19.2
60	48.0	U40600483045AAA	637	418	494	134	1826	20.6
66	53.0	U40660534045AAA	838	462	538	134	2434	28.9
72	57.0	U40720574445AAA	916	494	570	134	2677	30.7
78	62.0	U40780624845AA1	994	538	615	134	2921	32.8
84	68.0	U40840684845AA1	994	589	665	134	2921	33.5
90	70.0	U40900705045AA1	1033	606	682	134	3043	34.9
96	76.0	U40960765245AA1	1073	657	733	134	3164	36.0
108	84.0	U41080845845AA1	1190	724	800	134	3529	39.1
120	98.0	U41200986045AA1	1229	845	921	134	3651	41.7
132	106	U41321067645AA1	1618	1167	1497	134	4625	54.6
138	111	U41381117845AA1	1657	1208	1538	134	4746	55.7
144	115	U41441157845AA1	1657	1244	1574	134	4746	56.4
162	130	U41621308645AA1	1814	1370	1701	134	5233	61.0
168	131	U41681318645AA1	1814	1379	1709	134	5233	61.3
172	140	U41721408845AA1	1853	1456	1786	134	5355	63.1
180	144	U41801449045AA1	1892	1491	1821	134	5477	64.2
192	152	U4192152A445AA1	2170	1559	1889	134	6328	74.2
198	160	U4198160A845AA1	2249	1627	1957	134	6572	76.7
204	165	U4204165B045AA1	2288	1671	2001	134	6694	78.0
216	174	U4216174B445AA1	2366	1748	2078	134	6937	80.5
228	182	U4228182B645AA1	2405	1815	2146	134	7059	81.9
240	190	U4240190C045AA1	2483	1883	2213	134	7302	84.8

Notes:

1. Refer to Figure 4 for illustrations of dimensions B and C and Figure 5 for dimensions A and D.

* Phase-to-Phase clearances are expressed as minimum arrester center-to-center distances. Phase-to-Earth clearances are expressed as minimum arrester centerline-to-ground distances.

** Leakage distances shown are for standard housing – see page 8, digits 9 & 10 for optional housings available.

UltraQUIK™ Catalog Numbering System for UltraSIL Polymer-Housed VariSTAR Class 4 Arresters

1 U	2 4	3	4	5	6	7	8	9	10	11	12	13	14	15 A
---------------	---------------	---	---	---	---	---	---	---	----	----	----	----	----	----------------

Catalog Number Digits:

1 = "U" (UltraSIL Housed Arrester)

2 = "4" (IEC Class 4 Arrester)

3 through 8 = 7 (COV, U_c)

003002 = 3 kV (2.55 kV)	072057 = 72 kV (57.0 kV)
006005 = 6 kV (5.10 kV)	078062 = 78 kV (62.0 kV)
009007 = 9 kV (7.65 kV)	084068 = 84 kV (68.0 kV)
010008 = 10 kV (8.4 kV)	090070 = 90 kV (70.0 kV)
012010 = 12 kV (10.2 kV)	096076 = 96 kV (76.0 kV)
015012 = 15 kV (12.7 kV)	108084 = 108 kV (84.0 kV)
018015 = 18 kV (15.3 kV)	120098 = 120 kV (98.0 kV)
021017 = 21 kV (17.0 kV)	132106 = 132 kV (106 kV)
024019 = 24 kV (19.5 kV)	138111 = 138 kV (111 kV)
027022 = 27 kV (22.0 kV)	144115 = 144 kV (115 kV)
030024 = 30 kV (24.4 kV)	162130 = 162 kV (130 kV)
033027 = 33 kV (27.0 kV)	168131 = 168 kV (131 kV)
036029 = 36 kV (29.0 kV)	172140 = 172 kV (140 kV)
039031 = 39 kV (31.5 kV)	180144 = 180 kV (144 kV)
042034 = 42 kV (34.0 kV)	192152 = 192 kV (152 kV)
045036 = 45 kV (36.5 kV)	198160 = 198 kV (160 kV)
048039 = 48 kV (39.0 kV)	204165 = 204 kV (165 kV)
054042 = 54 kV (42.0 kV)	216174 = 216 kV (174 kV)
060048 = 60 kV (48.0 kV)	228182 = 228 kV (182 kV)
066053 = 66 kV (53.0 kV)	240190 = 240 kV (190 kV)

UltraQUIK Catalog Numbering System for UltraSIL Polymer-Housed VariSTAR Class 4 Arresters (Continued)

1 U	2 4	3	4	5	6	7	8	9	10	11	12	13	14	15 A
---------------	---------------	---	---	---	---	---	---	---	----	----	----	----	----	----------------

9 and 10 = Housing Code (Select from Table below):
 * = Standard Housing
 O = Housing Options
 + = Additional Housing Codes Available. Please contact your Cooper Sales Representative for additional information.

U _r Arrester Rating (kV mms)	Digits 9 & 10	08	10	12	14	16	18	20	22	24	26	28
	Leakage Length (mm)	487	609	730	852	974	1095	1217	1339	1460	1582	1704
3		*										
6			*	O								
9			*	O	O							
10			*	O	O							
12				*	O	O						
15					*	O	O					
18					*	O	O	O				
21						*	O	O	O			
24							*	O	O	O		
27							*	O	O	O	O	O
30								*	O	O	O	O
33									*	O	O	O
36									*	O	O	O
39									*	O	O	O
42										*	O	O
45											*	O
48											*	O
54												*
60												
66												
72												
75												
78												
84												
90												
96												
108												
120												

	62	64	66	68	70	72	74	76	78	80	82	84	86	88	90
	3773	3894	4016	4138	4260	4381	4503	4625	4746	4868	4990	5111	5233	5355	5477
90	+	+	+	+	+										
96	+	+	+	+	+	+									
108		+	+	+	+	+	+	+	+	+	+	+			
120						+	+	+	+	+	+	+	+	+	+
132								*	O	O	O	O	O	O	O
138									*	O	O	O	O	O	O
144									*	O	O	O	O	O	O
162													*	O	O
168													*	O	O
172														*	O
180															*
192															
198															
204															
216															
228															
240															

Notes:
 For U_r = 162 kV through 198 kV, Consult factory for housing codes above C0, Maximum Housing code available E2 (7700 mm creep),
 For U_r = 204 kV through 240 kV, Consult factory for housing codes above C0, Maximum Housing code available H2 (9300 mm creep).

Continued from facing page

U _r Arrester Rating (kV mms)	Digits 9 & 10	30	36	38	40	42	44	46	48	50	52	54	56	58	60
	Leakage Length (mm)	1826	2191	2312	2434	2556	2677	2799	2921	3043	3164	3286	3408	3529	3651
3															
6															
9															
10															
12															
15															
18															
21															
24															
27															
30															
33		○													
36		○													
39		○													
42		○													
45		○													
48		○													
54		○	+	+	+	+									
60					+	+									
66					*	○									
72							*	○	○	○	○				
75								*	○	○	○				
78									*	○	○	○	○	○	
84									*	○	○	○	○	○	
90										*	○	○	○	○	○
96											*	○	○	○	○
108														*	○
120															*

	92	94	96	98	A0	A2	A4	A6	A8	B0	B2	B4	B6	B8	C0
	5598	5720	5842	5963	6085	6207	6328	6450	6572	6694	6815	6937	7059	7180	7302
90															
96															
108															
120	+	+	+	+											
132	+	+	+	+											
138	+	+	+	+											
144	+	+	+	+											
162			+	+	+	+	+	+	+	+	+	+	+	+	+
168			+	+	+	+	+	+	+	+	+	+	+	+	+
172			+	+	+	+	+	+	+	+	+	+	+	+	+
180						+	+	+	+	+	+	+	+	+	+
192							*	○	○	○	○	○	○	○	○
198									*	○	○	○	○	○	○
204											○	○	○	○	○
216												*	○	○	○
228													*	○	○
240															*

Notes:

For U_r = 162 kV through 198 kV, Consult factory for housing codes above C0, Maximum Housing code available E2 (7700 mm creep),
 For U_r = 204 kV through 240 kV, Consult factory for housing codes above C0, Maximum Housing code available H2 (9300 mm creep).

UltraQUIK Catalog Numbering System for UltraSIL Polymer-Housed VariSTAR Class 4 Arresters (Continued)

1 U	2 4	3	4	5	6	7	8	9	10	11	12	13	14	15 A
---------------	---------------	---	---	---	---	---	---	---	----	----	----	----	----	----------------

11 = Line Terminal Options

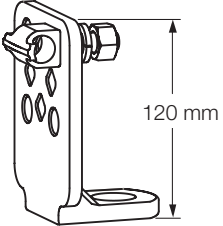
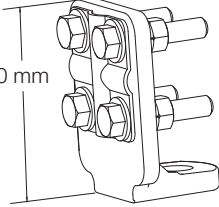
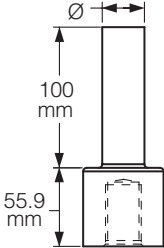
 <p>1 = Eyebolt Connector Accepts Copper or Aluminum Stranded Conductors up to 14 mm Ø</p>	 <p>4 = NEMA Four-hole Pad Accepts Copper or Aluminum Conductors up to 29 mm Ø (Standard)</p>	<p>D = 100 mm X 30 mm Ø Aluminum Cylindrical Stem Connector</p>  <p>H = Same as D but with 26 mm Ø</p>
--	--	--

12 = Earth Terminal Options

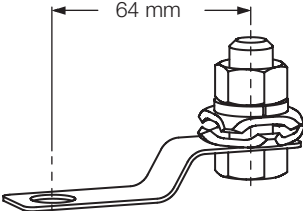
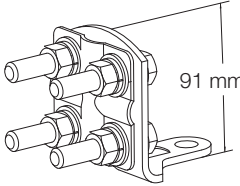
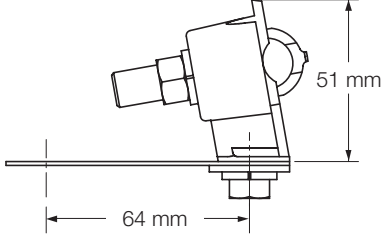
 <p>2 = Clamp Style Connector Accepts Copper or Aluminum Conductors up to 13 mm Ø</p>	 <p>5 = NEMA Four-hole Pad Accepts Copper or Aluminum Conductors up to 20 mm Ø (Standard)</p>	 <p>9 = Eyebolt Connector Accepts Copper or Aluminum Conductors up to 14 mm Ø</p>
--	---	---

13 = Mounting Arrangement

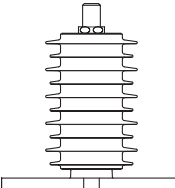
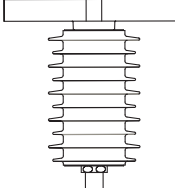
 <p>A = Mounting Base Located at Bottom (Standard)</p>	 <p>C = Mounting Base Located on Top (Inverted Suspension Mount)</p>
--	--

14 = Nameplate Information, See Figure 6

Nameplate information is per IEC 60099-4 and is available in the following languages.

- Specify:
- A** = English
 - B** = Spanish
 - C** = Portuguese

15 = Packaging

Arresters with housing codes 60 or less are shipped complete, ready for installation. Arresters with housing codes greater than 60 are shipped unassembled, requiring assembly during installation.

- A = Export packing, individually packed in cartons-Housings 06 through 46.
- 1 = Export packing, individually packed in cartons-Housings 48 and higher.

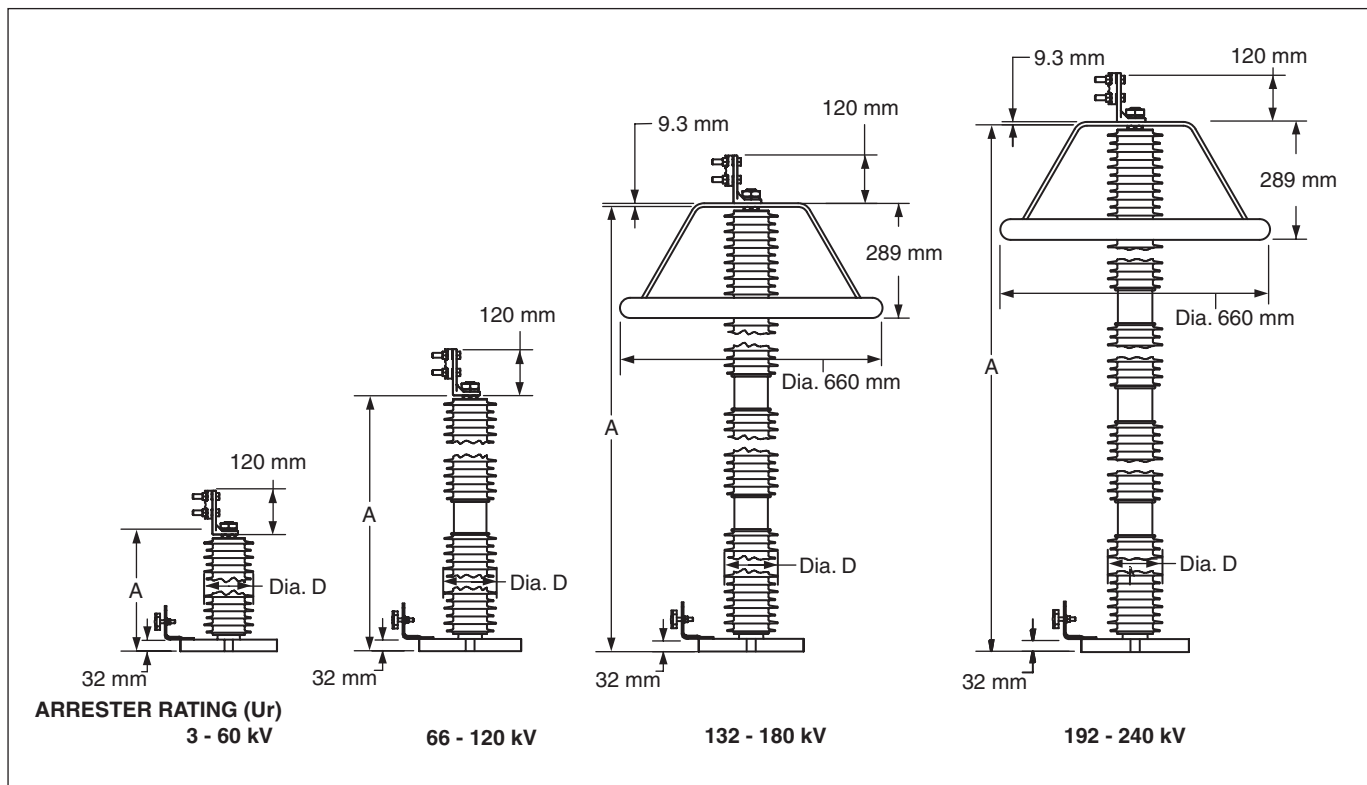

Figure 5.
Outline drawing of Standard UltraSIL Polymer-Housed VariSTAR Type U4 Arresters.

Notes:

Refer to Table 6 for dimensions A and D. Arresters shown with standard line terminal, Option 4 in digit 11 and with standard earth terminal, Option 5 in digit 12.

Outlines in Figure 5 represent standard arrester catalog numbers from Table 5. Outline dimensions will vary when optional housing codes are selected from page 8. Consult factory for more information.

NAMEPLATE INFORMATION

A stainless steel nameplate is attached to the base of every UltraSIL Polymer-Housed Type U4 Arrester. The arrester catalog number, serial number, year of manufacture, U_r , U_c , and pressure relief rating are among the details provided on the nameplate. See Figure 6 for an example of a base nameplate. For multi-unit arresters with housing codes greater than 60, an additional nameplate is provided on the base as shown in Figure 7.

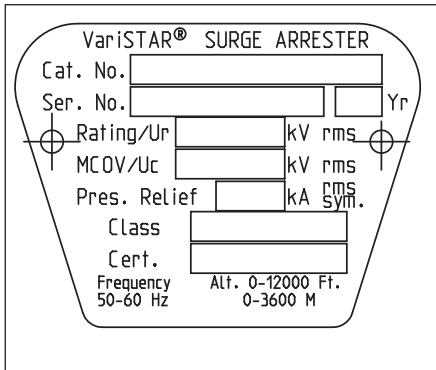

Figure 6. Arrester base nameplate (English version).

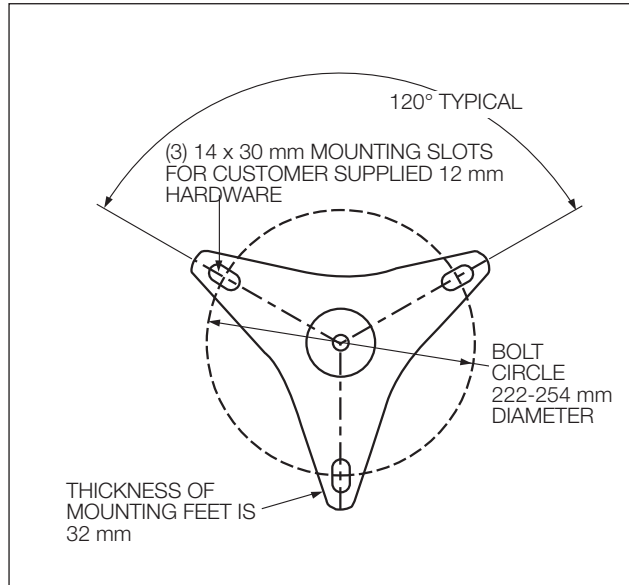

Figure 8. Base mounting.

ADDITIONAL INFORMATION

TABLE 6
Product Literature

CP0410	Certified Test Report
IS235-93-1	Service and Installation Instructions

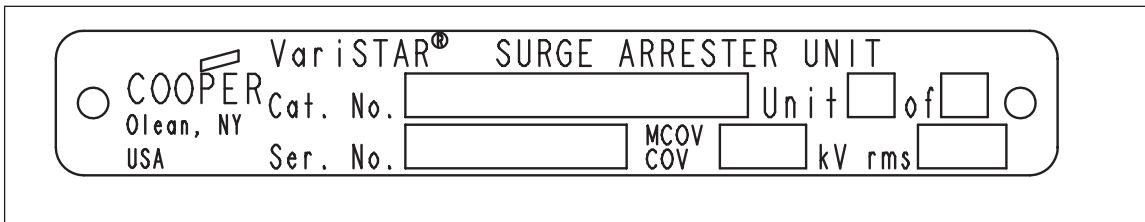

Figure 7. Detail of unit nameplate on base.