

# VariSTAR Type AZG4 Surge Arresters for Systems through 400 kV IEC 20-kA; Line Discharge Class 4

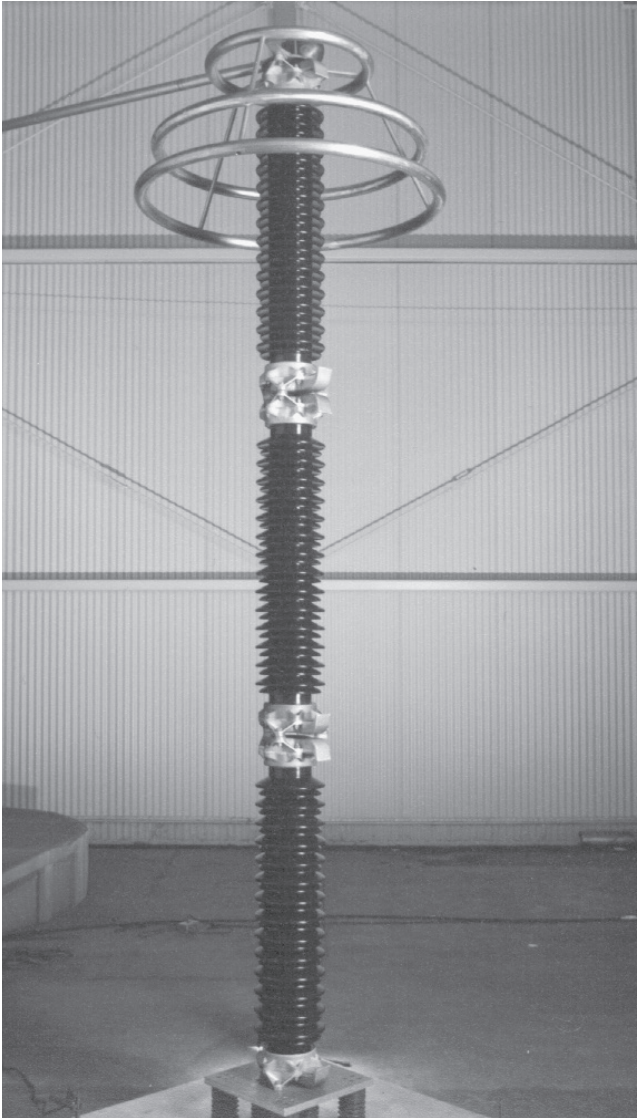

Figure 1.  
VariSTAR Type AZG4 Surge Arrester,  $U_r = 360$  kV.

**EATON**

Powering Business Worldwide

## General

Eaton's Cooper Power series VariSTAR™ AZG4 Surge Arresters incorporate the latest in metal oxide varistor (MOV) technology. These arresters are totally gapless and are constructed of a single series column of 76 mm diameter MOV disks. The arrester is designed and tested exclusively to the requirements of the International Standard IEC 99-4 and is available for the protection of high-voltage systems through 400 kV.

Eaton assures the design integrity of the AZG4 arrester through a rigorous testing program conducted at the Thomas A. Edison Technical Center and at the factory in Olean, NY USA. The availability of complete "in-house" testing facilities assures that as continuous process improvements are made, they are professionally validated to the highest technical standards.

## Construction

### External

The wet-process porcelain housing features an alternating shed design that provides excellent resistance to the effects of atmospheric housing contamination. AZG4 arresters are optionally available with extra creepage porcelains for use in areas with extreme conditions of natural atmospheric and man-made pollution. The dielectric properties of the porcelain are coordinated with the electrical protective characteristics of the arrester in accordance with the requirements of IEC 99-4. The unit end castings are of a corrosion resistant aluminum alloy configured for interchangeable mounting with many manufacturers' arresters for ease in upgrading to VariSTAR Arrester technology. This three-footed mounting is provided on a 111 to 127 mm radius pattern for customer supplied 12 mm diameter hardware. High cantilever strength assures mechanical integrity. Housings are available in standard grey or optional brown glaze color. Standard line and earth terminal connectors accommodate up to 335 mm<sup>2</sup> conductor. Insulating bases and discharge counters are optionally available for in-service monitoring of arrester discharge activity.

The end fittings and porcelain housing of each arrester unit are sealed and tested by means of a sensitive helium mass spectrometer; this assures that the quality and insulation protection provided by the arrester is never compromised over its lifetime by the entrance of moisture. A corrosion resistant nameplate is provided and contains all information required by IEC Standards; in addition, stacking arrangement information is provided for multi-unit arresters. Voltage grading rings are included for arresters used on systems 230 kV and higher (ratings 172 kV and above).

**Table 1**

System Application Voltages	3-400 kV
Rated Arrester Voltages, $U_r$	3-360 kV
Power System Frequency	50 or 60 Hz
Applicable Design and Test Standard	IEC 99-4
Nominal Discharge Current	20 kA
Line Discharge Class	4
High Current Withstand	100 kA
Pressure Relief Class	63 kA rms sym
Rated Discharge Energy	8.9 kJ/kV of $U_C$ or 7.2 kJ/kV of $U_r$

## Features and detailed description

### Internal

The VariSTAR AZG4 Arrester's design reliability is enhanced by its totally gapless design. Gapless construction makes a significant contribution to the performance of arresters through the elimination of gap reseat as a consideration associated with the discharge of high switching surge currents and energies. The specially formulated metal-oxide varistors, manufactured under Eaton's exclusive quality control, provide exceptional non-linear protective characteristics, durability, and dependable energy dissipation capabilities.

### Operation

The VariSTAR AZG4 Arrester conducts only a few milliamperes of leakage current when energized at normal system voltage. When an overvoltage event occurs, the arrester conducts only the current and consequently the energy necessary to limit the overvoltage to its protective level. By doing so it provides precise and predictable protection, minimizes the absorbed energy, and discharges no power frequency system currents.

VariSTAR Arresters are ideal for the protection of critical electrical apparatus in areas of high lightning incidence and for repeated protection against high-energy switching surges generated on high voltage transmission systems. Many formerly difficult applications such as those associated with low impedance circuits due to large capacitor banks, cables and multiple transmission lines are easily analyzed and VariSTAR Arresters applied where conventional arresters cannot be used.

In the unlikely event of an arrester failure, a directed pressure relief system is incorporated in the VariSTAR AZG4 Arrester Design. A directed pressure venting system rapidly relieves internal pressure and transfers the internal arc to the outside of the arrester porcelain through vent ports in the end castings. When called upon to operate, this mechanism vents internal pressures in fractions of a cycle, simultaneously transferring the fault current arc to the outside, preventing violent arrester failure. This mechanism is effective for system fault currents up to 63,000 A rms symmetrical (163,000 A first crest) of 60 degrees celsius, and that after the overvoltage durations shown, demonstrate that the arrester will thermally recover when once again energized at COV ( $U_C$ ).

### General application recommendations

The rating of an arrester is the power frequency line-to-earth voltage at which the arrester is designed to pass the operating duty test. Table 2 provides a general guide for the selection of the proper arrester for a given system voltage. Eaton's application engineers are available to make specific system application recommendations.

### Selection of arrester rating

In arrester rating selection it is preferable to determine the lowest arrester rating that will ensure satisfactory operation. This is the optimum solution because the arrester selected will not only provide

the greatest margin of insulation protection but also be the most economical choice.

Increasing arrester rating above the minimum increases the likelihood of arrester survival during potential system contingencies but compromises the protection of equipment insulation. Table 2 lists VariSTAR AZG4 Arrester ratings commonly used on various 3-phase systems.

Rating selection should begin with consideration of the maximum system operating voltage. The maximum power frequency voltage expected under normal system conditions (expressed line-to-earth) should not exceed the selected arrester's continuous operating voltage ( $U_C$ ).

The temporary overvoltage (TOV) capability of the VariSTAR AZG4 Arrester is shown in Figure 3. The curves indicate the arrester's ability to withstand abnormal system power frequency (sinusoidal) overvoltages for various durations. The values shown assume that the arrester has been energized at COV ( $U_C$ ) prior to an overvoltage event, that the arrester is in an ambient temperature of 60 degrees celsius, and that after the overvoltage durations shown, demonstrate that the arrester will thermally recover when once again energized at COV ( $U_C$ ).

It is not recommended that the TOV curve be extended for periods in excess of 10,000 seconds (2.8 hrs). For ungrounded systems (systems utilizing high impedance or resonant grounding and other systems where the line-to-earth voltage may be elevated to line-to-line voltages for extended periods) arresters having a COV ( $U_C$ ) equal to line-to-line voltage may be required.

For non-sinusoidal transient voltages caused by system switching operations, a transient network analyzer (TNA) study is recommended; Eaton's engineers are available to make these studies.

**Figure 2. VariSTAR Type AZG4 Arrester construction details.**

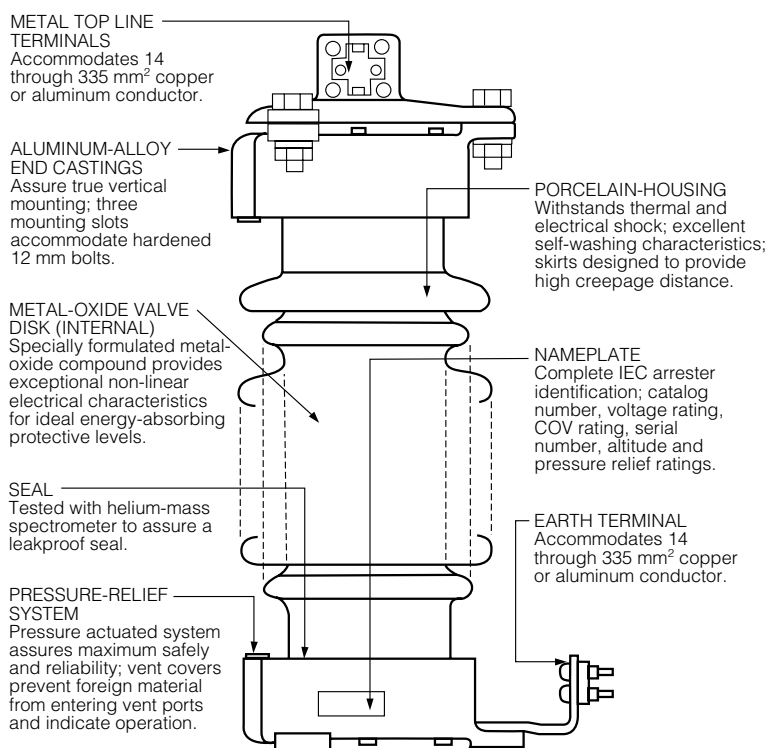

Figure 3 also illustrates the arrester's TOV capabilities with and without prior switching surge duties of up to a maximum capability of 8.9 kJ/kV of COV ( $U_C$ ).

To assure proper application, the following information is normally required:

1. Maximum system operating voltage.
2. System grounding conditions.
  - A. For four-wire circuits, grounding conditions depend upon whether the system is multi-grounded, whether it has neutral impedance, and whether common primary and secondary neutrals are used.
  - B. For three-wire circuits, grounding conditions depend upon whether the system is solidly grounded at the source, grounded through neutral impedance at the source, grounded through transformers, or ungrounded.

Where unusual conditions exist (high ground resistance, high capacitive load, unusual switching surge duty, etc.), the following supplementary information is required:

1. Type of unusual condition.
2. BIL of equipment and line insulation.
3. Type of construction (phase spacing, length of line, conductor size, etc.).
4. Grounding and phase-sequence components of source impedances.
5. Phase-sequence components of load impedances.
6. Available fault current.
7. Line switching details.
8. Ferranti voltage rise.
9. Potential for loss of neutral earthing during system events.

### Performance and protective characteristics

Table 4, "Residual Voltages – Maximum Guaranteed Protective Characteristics For Type AZG4 Surge Arresters" displays the Arrester Rating ( $U_r$ ), Continuous Operating Voltage ( $U_C$ ) and the guaranteed protective characteristics. The Steep Current Impulse protective level is the maximum residual voltage for an impulse current of specified magnitude rising to crest in one microsecond. Lightning Impulse Residual Voltages represent the maximum protective levels exhibited by the arrester when discharging lightning currents of the standard 8/20 microsecond waveshape. The maximum Switching Impulse Residual Voltages are based on a switching surge current having a time to crest of 30 microseconds. For all ratings the switching surge energy absorption capability is 8.9 kJ/kV of COV ( $U_C$ ).

**Table 2. Arrester ratings commonly used on 3-phase systems**

System Voltages L-L (kV)		Arrester Ratings (kV)	
Nominal	Max	Grounded Circuits	High-Impedance/ Ungrounded Circuits
3.3	3.7	3	–
6.6	7.3	6	9
10.0	11.5	9	12-15
11.0	12.0	9-10	12-15
16.4	18.0	15	18-21
22.0	24.0	18-21	24-27
33.0	36.3	27-30	36-39
47.0	52.0	39-48	54-60
66.0	72.0	54-60	66-84
91.0	100	78-84	90-96
110	123	96-108	120-138
132	145	108-120	132-144
155	170	132-144	162-172
220	245	180-198	204-240
275	300	216-240	258-294
330	362	258-288	294-360
400	420	312-360	-

**Figure 3. Temporary overvoltage capability**

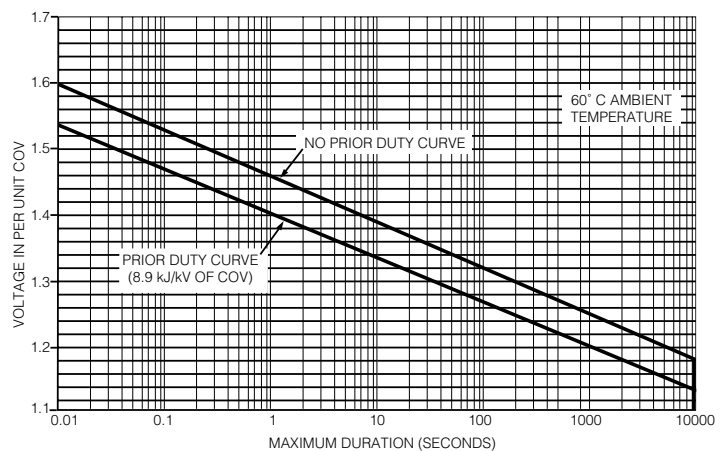

## Routine tests

A complete production test program assures the quality of every VariSTAR AZG4 Surge Arrester. Each completed arrester is required to satisfactorily pass the following test regimen conducted in accordance with the procedures established in IEC 99-4: Partial Discharge Test at 1.05 times  $U_C$ .

- Partial Discharge Test at 1.05 times  $U_C$ .
- Reference Voltage Test ( $U_{ref}$ ), voltage measured at reference current.
- Leakage current is measured at  $U_C$  and  $U_r$ .
- Residual Voltage Test.
- Sealing Effectiveness Test of Housing by helium mass spectrometer.

## Standards

The VariSTAR AZG4 Surge Arrester has been tested and certified to IEC Standard 60099-4 (99-4). Guaranteed performance characteristics are specified in this catalog section and in the relevant "Design Certification Test Report," CP9819.

**Table 3. Type AZG4 Surge Arrester housing insulation withstand characteristics**

Housing Designation*	Leakage Distance (mm)	Arc Distance (mm)	BIL - kV Pk 1.2/50 Wave	50/60 Hz Wet (60s)-kV rms	Switching-Wet (kV Pk)
41	234	144	130	35	**
42	406	208	170	60	**
43	665	303	230	90	**
44	922	399	265	125	**
45	1267	525	320	165	**
46	1646	615	365	170	**
47	1872	688	385	195	**
48	2540	905	505	250	**
49	3226	1122	650	285	**
51	3292	1230	725	345	**
52	3518	1303	735	360	**
53	3744	1375	770	395	**
54	4186	1520	865	415	**
55	4412	1592	880	450	**
56	4872	1737	985	450	**
57	3292	1166	705	335	**
58	3518	1234	780	370	**
59	3744	1306	790	385	**
60	4186	1455	850	400	**
61	4412	1523	920	440	**
62	4872	1564	925	440	750
63	5098	1636	930	480	810
64	5766	1853	1065	530	915
65	6452	2070	1185	545	1015
67	6744	2130	1265	625	1065
68	6970	2202	1300	655	1100
69	7412	2347	1375	675	1150
70	7638	2420	1405	705	1190
71	8098	2564	1475	710	1250
72	8306	2637	1515	760	1280
74	8992	2781	1440	760	1235
75	9677	2998	1535	810	1315

\* Housing designation is indicated in the 6th and 7th position of the catalog number.

\*\* IEC Standard 60099-4 (99-4) 1991 does not require Wet Switching Surge Withstand tests for arresters with rated voltage ( $U_r$ ) below 200 kV. Housing designations 61 and below are not used in arresters rated above 198 kV

Table 4. Residual Voltages - Maximum Guaranteed Protective Characteristics for Type AZG3 Surge Arresters

Arrester Rating Ur (kV, rms)	Arrester MCOV Uc (kV, rms)	Steep Current Residual Voltage (kV Crest) 10 kA		Lightning Impulse Residual Voltage (kV Crest) 8/20 $\mu$ s Current Wave						Switching Impulse Residual Voltage (kV Crest) 30/60 Current Wave			
		10 kA	20 kA	1.5 kA	3 kA	5 kA	10 kA	20 kA	40 kA	250 A	500 A	1000 A	2000 A
3	2.55	14.1	16.3	6.8	7.2	7.4	8.1	9.0	10.9	6.2	6.4	6.6	7.0
6	5.10	23.4	26.1	13.6	14.2	14.8	15.9	17.5	20.4	12.4	12.8	13.2	13.9
9	7.65	32.7	35.8	20.3	21.2	22.0	23.6	25.9	29.8	18.5	19.0	19.7	20.6
10	8.40	35.4	38.7	22.3	23.3	24.2	25.9	28.5	32.6	20.3	20.9	21.6	22.6
12	10.2	42.0	45.6	27.1	28.3	29.3	31.4	34.5	39.4	24.7	25.4	26.3	27.4
15	12.7	51.2	55.2	33.7	35.2	36.5	39.0	42.8	48.6	30.7	31.6	32.7	34.1
18	15.3	60.8	65.3	40.7	42.5	47.5	44.0	47.0	51.6	58.4	37.1	38.1	39.4
21	17.0	67.0	71.8	45.2	47.2	48.9	52.2	57.3	64.7	41.2	42.4	43.8	45.7
24	19.5	76.1	81.4	51.8	54.1	56.0	59.8	65.6	74.0	47.2	48.6	50.2	52.3
27	22.0	85.2	90.9	58.4	61.0	63.2	67.4	73.9	83.3	53.3	54.7	56.7	59.0
30	24.4	94.0	100	64.8	67.6	70.0	74.7	81.9	92.2	59.1	60.7	62.8	65.4
33	27.5	105	112	73.0	76.3	79.0	84.2	92.3	104	66.6	68.4	70.8	73.7
36	29.0	111	118	77.0	80.4	83.3	88.8	97.3	109	70.3	72.2	74.7	77.7
39	31.5	120	128	83.6	87.3	90.4	96.4	106	119	76.3	78.4	81.1	84.4
42	34.0	123	130	85.6	89.3	92.5	98.6	108	121	78.1	80.2	83.0	86.3
45	36.5	131	139	91.8	95.9	99.3	106	116	130	83.8	86.0	89.1	92.6
48	39	140	148	98.1	102	106	113	124	139	89.5	91.9	95.1	98.9
54	42	150	159	106	110	114	122	133	150	96.4	99.0	103	107
60	48	171	181	121	126	131	139	152	171	110	113	117	122
66	53	189	199	133	139	144	154	168	188	122	125	129	134
72	57	202	214	143	150	155	165	181	202	131	134	139	145
78	62	220	232	156	163	169	180	197	220	142	146	151	157
84	68	241	254	171	179	185	197	216	241	156	160	166	172
90	70	248	261	176	184	190	203	222	248	161	165	171	177
96	76	268	283	191	200	207	220	241	269	174	179	185	193
108	84	296	312	211	221	228	243	266	298	193	198	205	213
120	98	345	363	246	257	266	284	311	347	225	231	239	248
132	106	377	399	267	278	288	307	336	377	243	250	259	269
138	111	394	417	279	292	302	321	352	394	255	262	271	281
144	115	408	431	289	302	313	333	365	408	264	271	281	292
162	130	460	486	327	341	353	376	412	461	298	306	317	330
168	131	464	490	329	344	356	379	415	465	301	309	320	332
172	140	495	522	352	368	381	405	444	497	321	330	342	355
180	144	509	537	362	378	391	417	457	511	330	339	351	365
192	152	537	566	382	399	413	440	482	539	349	358	371	385
198	160	564	595	402	420	435	463	507	567	367	377	390	405
204	165	582	613	415	433	448	477	523	585	379	389	403	418
216	174	613	646	438	457	473	504	552	616	399	410	425	441
228	182	641	675	458	478	495	527	577	645	418	429	444	461
240	190	668	704	478	499	516	550	602	673	436	448	463	481
258	209	739	780	526	549	568	605	663	741	480	493	510	530
264	212	749	791	533	557	576	614	672	752	487	500	517	537

Table 4. Residual Voltages - Maximum Guaranteed Protective Characteristics for Type AZG3 Surge Arresters continued

Arrester Rating Ur (kV, rms)	Arrester MCOV Uc (kV, rms)	Steep Current Residual Voltage (kV Crest) 10 kA		Lightning Impulse Residual Voltage (kV Crest) 8/20 $\mu$ s Current Wave					Switching Impulse Residual Voltage (kV Crest) 30/60 Current Wave				
		10 kA	20 kA	1.5 kA	3 kA	5 kA	10 kA	20 kA	40 kA	250 A	500 A	1000 A	2000 A
276	220	777	820	553	578	598	637	698	780	505	518	537	558
288	230	812	856	578	604	625	666	729	815	528	542	561	583
294	235	829	875	591	617	639	680	745	833	539	554	573	596
300	239	843	889	601	628	650	692	758	847	549	563	583	606
312	245	864	911	616	643	666	709	777	868	562	577	598	621
330	267	940	991	671	701	726	772	846	946	613	629	651	676
336	269	947	998	676	706	731	778	853	953	617	634	656	682
360	289	1016	1071	727	759	785	836	916	1023	663	681	705	732

### Dimensions and mounting

Figure 4 illustrates an in-line mounting arrangement; the applicable values of "C" and "D" may be found in Table 5. Line and earth terminal details are shown in Figure 5; the supplied terminals accommodate aluminum and copper conductors to a maximum size of 335 mm<sup>2</sup>. For other conductors the terminal drilling pattern shown will accommodate industry standard two (2) and four (4) hole flat pad connectors having a 45 mm spacing. Figure 6 provides the dimensional details for universal base mounting.

The vent port in the base must be directed away from any adjacent equipment to control and prevent ionized gases from damaging other equipment in the unlikely event of arrester failure.

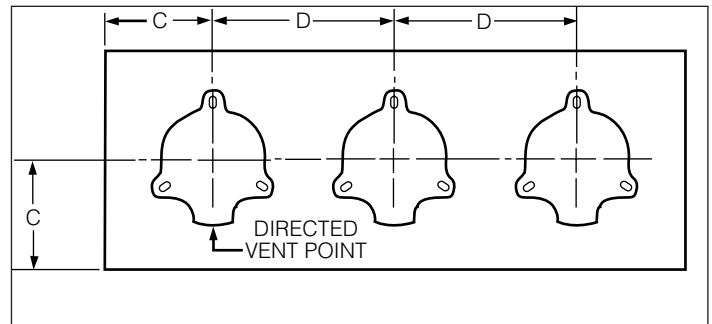

Figure 4. Three-phase in-line mounting.

Note: Refer to Table 5 for dimensions C and D.

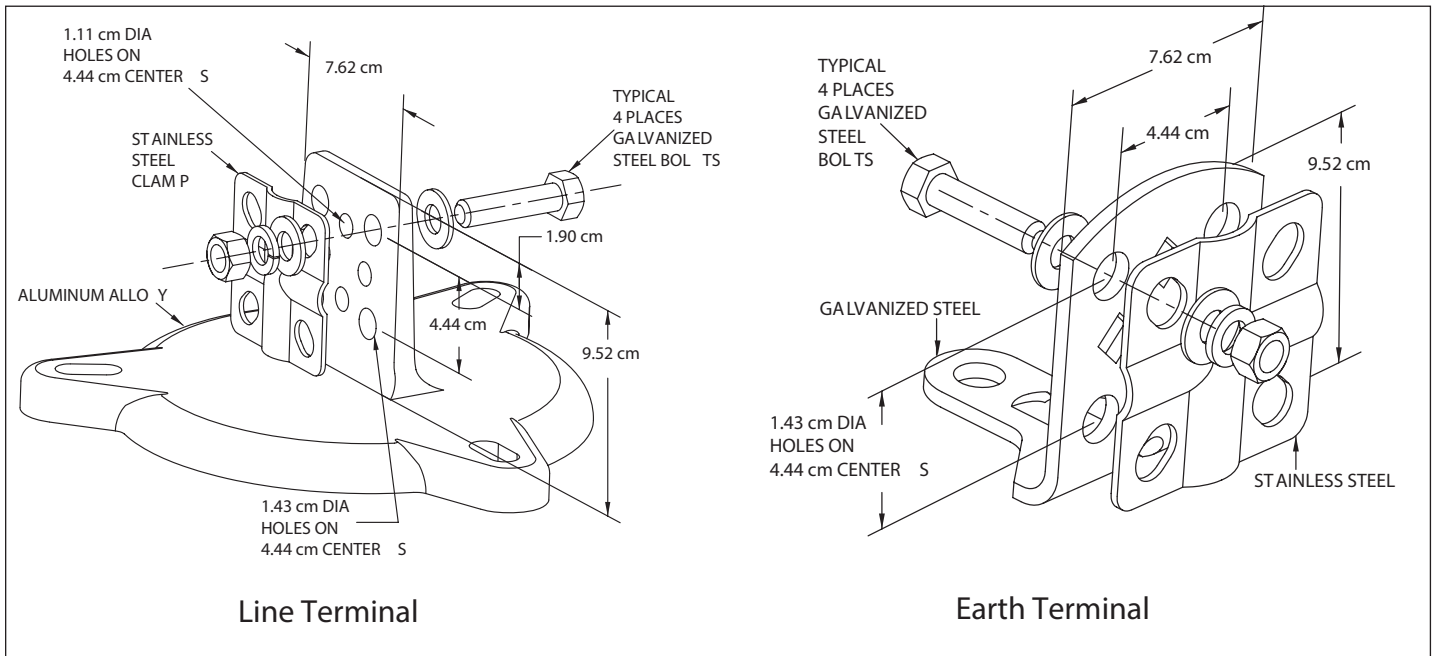

Figure 5. Line and earth terminals (suitable for copper or aluminum conductors up to 335 mm<sup>2</sup> (up to a maximum diameter of 20 mm)).

Table 5. Catalog Numbers and Dimensional Information (See Figures 4 & 8)

U <sub>r</sub> Arrester Rating (kV, rms)	U <sub>c</sub> Arrester COV (kV, rms)	Catalog Number	Dim. A (mm)	Figure 7 View Number	Dim. B Minimum Phase-to-Earth* Clearance (mm)	Dim. C Minimum Phase-to-Phase* Clearance (mm)	Housing Leakage Distance (mm)	Arrester Mass (kg)
3	2.55	AZG4041G002003	471	1	163	308	234	19
6	5.10	AZG4041G005006	471	1	165	309	234	19
9	7.65	AZG4041G007009	471	1	173	317	234	20
10	8.40	AZG4042G008010	535	1	176	320	406	23
12	10.2	AZG4042G010012	535	1	186	330	406	24
15	12.7	AZG4042G012015	535	1	202	347	406	24
18	15.3	AZG4043G015018	630	1	223	367	665	28
21	17.0	AZG4043G017021	630	1	237	382	665	29
24	19.5	AZG4043G019024	630	1	241	385	665	30
27	22.0	AZG4044G022027	725	1	261	406	922	35
30	24.4	AZG4044G024030	725	1	308	452	922	36
33	27.5	AZG4044G027033	725	1	308	452	922	36
36	29.0	AZG4044G029036	725	1	320	465	922	36
39	31.5	AZG4045G031039	852	1	341	486	1267	43
42	34.0	AZG4045G034042	852	1	347	492	1267	43
45	36.5	AZG4045G036045	852	1	367	512	1267	44
48	39.0	AZG4045G039048	852	1	387	531	1267	44
54	42.0	AZG4046G042054	929	1	411	556	1646	52
60	48.0	AZG4046G048060	929	1	458	603	1646	53
66	53.0	AZG4047G053066	1002	1	610	641	1872	59
72	57.0	AZG4047G057072	1002	1	496	641	1872	59
78	62.0	AZG4048G062078	1219	1	529	674	1872	59
84	68.0	AZG4048G068084	1219	1	617	762	2540	70
90	70.0	AZG4048G070090	1219	1	634	778	2540	72
96	76.0	AZG4048G076096	1219	1	680	825	2540	73
108	84.0	AZG4049G084108	1436	1	743	888	3226	93
120	98.0	AZG4049G098120	1436	1	853	998	3226	96
132	106	AZG4052G106132	1817	2	919	1064	3518	110
138	111	AZG4052G111138	1817	2	960	1105	3518	111
144	115	AZG4053G115144	1890	2	991	1135	3744	117
162	130	AZG4054G130162	2034	2	1109	1253	4186	125
168	131	AZG4055G131168	2107	2	1117	1261	4412	130
172	140	AZG4061G140172	2116	3	1374	1704	4412	136
180	144	AZG4062G144180	2261	3	1407	1737	4872	150
192	152	AZG4062G152192	2261	3	1467	1797	4872	152
198	160	AZG4063G160198	2333	3	1533	1863	5098	158
204	165	AZG4064G165204	2550	3	1571	1902	5766	169
216	174	AZG4064G174216	2768	3	1646	1976	5766	171
228	182	AZG4065G182228	2768	3	1706	2036	6452	191
240	190	AZG4065G190240	2768	3	1772	2102	6452	193
258	209	AZG4067G209258	3149	4	2126	2659	6744	214
264	212	AZG4067G212264	3149	4	2151	2684	6744	214
276	220	AZG4069G220276	3366	4	2211	2745	7412	226
288	230	AZG4069G230288	3366	4	2293	2827	7412	228
294	235	AZG4070G235294	3438	5	2332	2865	7638	238

Table 5. Catalog Numbers and Dimensional Information (See Figures 4 & 8) continued

Ur Arrester Rating (kV, rms)	Uc Arrester COV (kV, rms)	Catalog Number	Dim. A (mm)	Figure 7 View Number	Dim. B Minimum Phase-to-Earth* Clearance (mm)	Dim. C Minimum Phase-to-Phase* Clearance (mm)	Housing Leakage Distance (mm)	Arrester Mass (kg)
300	239	AZG4070G239300	3438	5	2365	2898	7638	238
312	245	AZG4071G245312	3583	5	2411	2945	8098	253
330	267	AZG4074G267330	3872	6	2750	3448	8992	274
336	269	AZG4074G269336	3872	6	2763	3462	8992	275
360	289	AZG4075G289360	4090	6	2925	3624	9677	297

Table 5 Notes:

- All arresters are available in grey (standard) or brown porcelain glaze. For brown glaze, substitute "B" for "G" in the eighth position of the catalog number.
  - Cantilever strength for ratings 3-48 kV=10,200 NM and for ratings 54-360 kV=13,550 NM. Maximum working load should not exceed 40% of this value.
  - Refer to Figure 4 for Illustration of Dimensions C and C and Figure 8 for Dimension A.
- \* Phase-to-Earth clearances are expressed as minimum arrester centerline-to-earth distances. Phase-to-Phase clearances are expressed as minimum arrester center-to-center distances.

Figure 6. Base mounting

Note: To develop rated cantilever strength use 254 mm bolt circle diameter and hardened bolts.

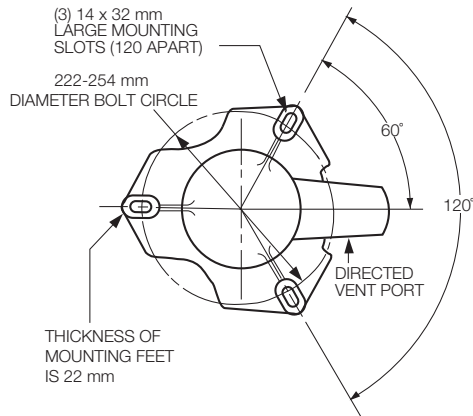

Figure 7. Arrester Nameplate.

Note: Refer to Figure 2.

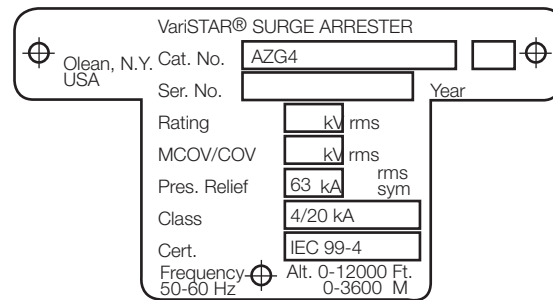
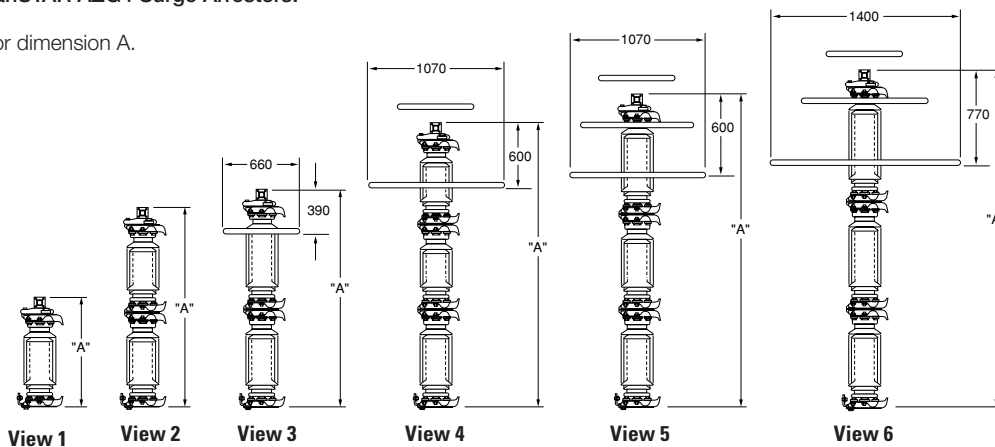

Figure 8. Outlines of VariSTAR AZG4 Surge Arresters.

Note: Refer to Table 5 for dimension A.



Eaton  
1000 Eaton Boulevard  
Cleveland, OH 44122  
United States  
Eaton.com

Eaton's Power Systems Division  
2300 Badger Drive  
Waukesha, WI 53188  
United States  
Eaton.com/cooperpowerseries

© 2016 Eaton  
All Rights Reserved  
Printed in USA  
Publication No. CA235032EN

Eaton is a registered trademark.

All trademarks are property of their respective owners.

For Eaton's Cooper Power series product information call 1-877-277-4636 or visit: [www.eaton.com/cooperpowerseries](http://www.eaton.com/cooperpowerseries).