

200 A, 35 kV class tri-clamp bushing well with fixed or removable stud



General

Eaton's Cooper Power™ series 200 A, 35 kV class tri-clamp bushing well meets the full requirements of the latest revision of the IEEE Std 386™-1995 standard—Separable Insulated Connector Systems.

It is designed for the termination of primary winding leads at the front plate of fluid-filled apparatus rated at either 8.3/14.4 kV, 15.2/26.3 kV, 16.2/28.0 kV (Canadian Applications) or 21.1/35 kV.

The tri-clamp bushing well is externally clamped for sidewall mounting on single- or three-phase transformers filled with transformer oil, Envirotemp™ FR3™ fluid or an approved equivalent. It is available to fit a 2.56 inch (65 mm) mounting hole and mates with all bushing inserts meeting applicable IEEE® standards. Its knurled copper stud with rolled threads provides excellent conductivity and strength.

A removable stud option is available. It offers easy field replacement of the bushing stud with a standard 5/8" socket wrench in the event of damage or breakage in the field. A 7/64" hex has been provided in the portion of the stud which mates into the bushing insert. Should breakage occur here this feature allows for easy stud removal from the insert.

The tri-clamp bushing wells are molded with high temperature nylon (HTN). The Zytel® HTN fulfills the required application needs for temperature stability, strength, toughness, low moisture absorption and retention of viable mechanical and electrical properties in humid high-temperature environments. The gasket surfaces provide controlled compression and containment of the highly resilient Buna-N rubber gasket.

Attributes

- Molded-in semi-conductive collar
- No additional clamps required
- Bail tabs molded into tri-clamp body
- Corrosion problems eliminated, no need for metal clamps

EATON

Powering Business Worldwide

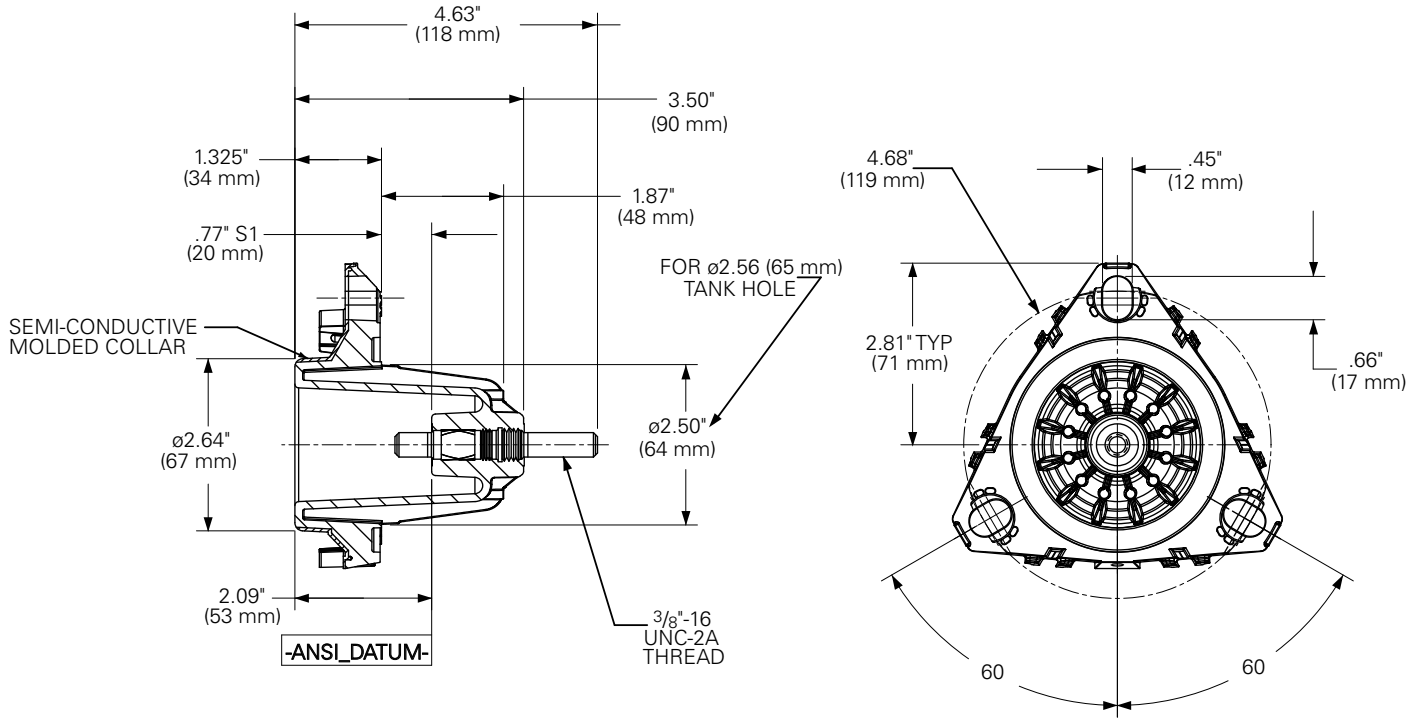

Figure 1. 200 A, 35 kV Class bushing well, with FIXED STUD feature shown.

Note: Dimensions given are for reference only.

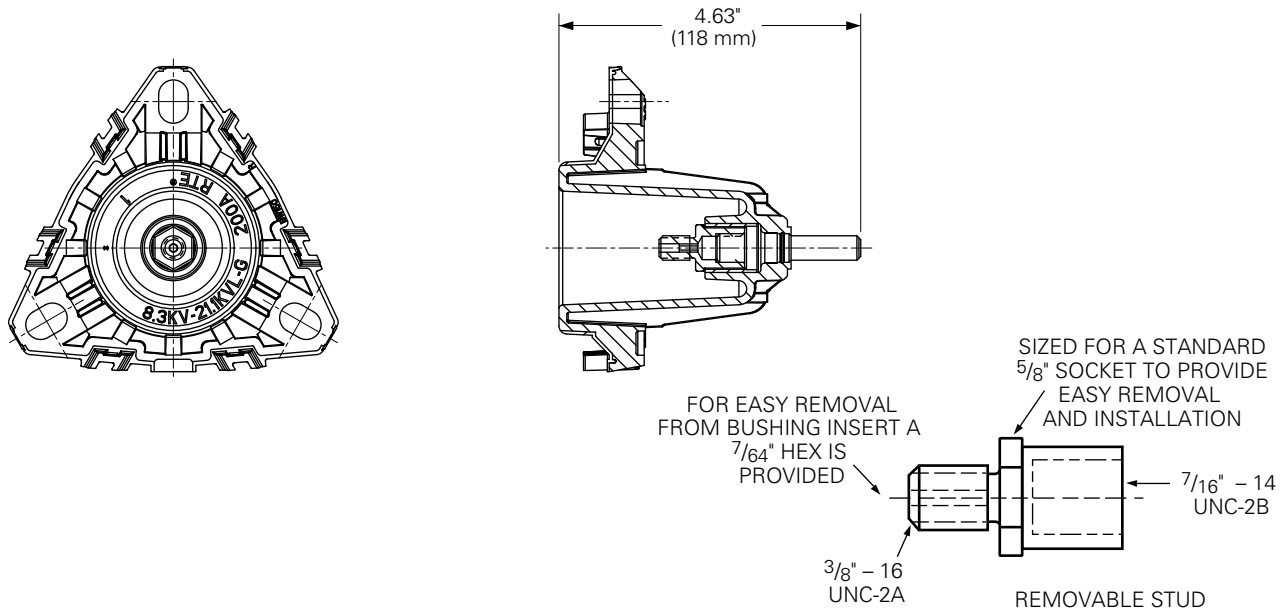

Figure 2. 200 A, 35 kV Class bushing well, with REMOVABLE STUD feature shown.

Note: Additional dimensions for Figure 3 can be found in Figure 2.

Installation

The tri-clamp bushing well is installed in the front plate of the oil-filled apparatus with a gasket on the internal shank of the well. A bushing well insert is installed in the well only while the apparatus is de-energized. An auxiliary ground lead is attached to the insert and ground. Refer to Installation Instruction Sheets S800-35-2 and Bushing Well Insert Installation Instruction S500-12-1 for details.

Production tests

- ac 60 Hz 1 Minute Withstand
 - 50 kV
- Minimum Corona Voltage Level
 - 26.0 kV

Tests conducted in accordance with Eaton requirements:

- Physical Inspection
- Periodic Dissection
- Periodic Fluoroscopic Analysis (X-ray)

Table 1. Voltage Ratings and Characteristics

Description	kV
Standard Voltage Class	35
Maximum Rating Phase-to-ground	21.1
ac 60 Hz 1 Minute Withstand	50
dc 15 Minute Withstand	103
BIL and Full Wave Crest	150
Minimum Corona Voltage Level	26

Voltage ratings and characteristics are in accordance with the IEEE 386™-1995 standard and applicable Canadian requirements.

Table 2. Current Ratings and Characteristics

Description	Amperes
Continuous	200 A rms
Short Time	10,000 A rms symmetrical for 0.17 s
	3,500 A rms symmetrical for 3.0 s

Current ratings and characteristics are in accordance with the IEEE 386™-1995 standard and applicable Canadian requirements.



Figure 3. Removable copper stud.

Ordering information

To order a 35 kV Class Tri-Clamp Bushing Well, specify bushing well from Table 3. The gasket is included with the bushing well.

Table 3. Bushing Wells, Gaskets, and Accessories

Description	Catalog Number	Figure
Bushing Well with Fixed Stud	BW150F**	1
Bushing Well with Removable Stud	BW150R**	2
Bushing Well Shipping Cap*	2638640C01	
Gasket*	0537980C22	
Removable Stud Replacement Kit	2639081B01B	2 & 3
Grounding Tab (Stainless Steel)	0739658A02	

* Bushing well shipping cap and gasket are included with all bushing wells.

** If ordering less than standard box quantity of 40 pieces, add an "X" to the end of the catalog number.

4.7" (120 mm) MIN. DIA. EXTERIOR MOUNTING SURFACE BETWEEN THE DOTTED LINE AND TANK HOLE TO BE FLAT AND CLEAR OF

SURFACE OBSTRUCTIONS, SUCH AS WELD SPLATTER.

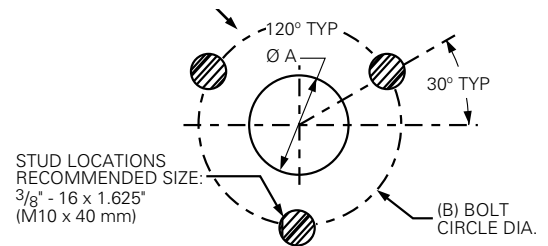

3-STUDED BUSHING CLAMP MOUNTING HOLE
 MOUNTING HOLE
 FOR 2.50" SHANK DIA.
 A DIM - 2.56" (65 mm) DIA. MINIMUM
 B DIM - 4.68" (119 mm) BOLT CIRCLE

Figure 4. Recommended tank wall dimensions.

Eaton
1000 Eaton Boulevard
Cleveland, OH 44122
United States
Eaton.com

Eaton's Cooper Power Systems Division
2300 Badger Drive
Waukesha, WI 53188
United States
Eaton.com/cooperpowerseries

© 2015 Eaton
All Rights Reserved
Printed in USA
Publication No. CA800016EN

Eaton and Cooper Power are valuable trademarks of Eaton in the U.S. and other countries. You are not permitted to use these trademarks without the prior written consent of Eaton.

IEEE Std 386™-1995 standard is a trademark of the Institute of Electrical and Electronics Engineers, Inc., (IEEE). This publication is not endorsed or approved by the IEEE.

Envirotemp™ and FR3™ are licensed trademarks of Cargill, Incorporated.
Zytel® is a registered trademark of DuPont.

For Eaton's Cooper Power series bushing well product information call 1-877-277-4636 or visit: www.eaton.com/cooperpowerseries.