

# LIQUID LEVEL GAUGE

## FEATURES

- Easy to see, high contrast float
- Non-porous solid float
- Heavy-duty, one piece Brass body
- Crystal clear, tempered glass lens
- Indicates large level span
- High temperature rating
- Unique double seal design
- Highly reflective, Stainless Steel float retainer
- Baffle dampens fluid turbulence
- Precision, 1/2"-14 NPT threaded mounting
- Large wrench flat area
- Complete model identification
- Thick rolled lens compression assures positive seal
- Meets Industry Standards



## HLG-1050 MODEL

The HLG-1050 is one model in the Heartland HLG family of liquid level gauges.

**APPLICATION** The Heartland model HLG-1050 liquid level gauge indicates the oil level in transformers, regulators and other electrical equipment. The HLG-1050 meets the Industry Standards and specifications for oil level indication in electrical equipment. Heartland Solution's HLG-1050 reliably indicates the oil level in either indoor or outdoor transformer, regulator and other electrical equipment applications.

## TECHNICAL DATA

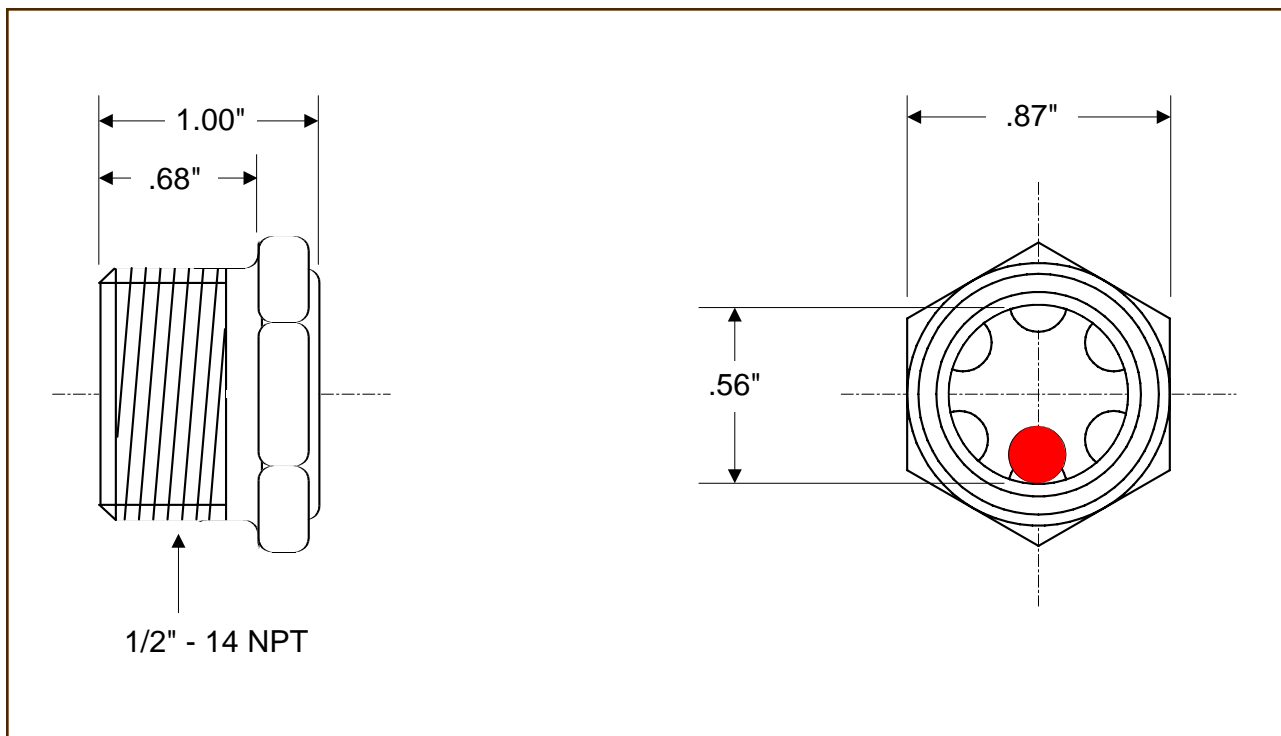

**OPERATION** The HLG-1050 liquid level gauge can be mounted in the side of the tank to indicate the oil level at that location. Multiple liquid level gauge are used when the desired indicating level exceeds the span of a single liquid level gauge. Most oils used in electrical equipment is colorless and difficult to see without the aid of the float. The high contrast float in the HLG-1050 will indicate the level in oils with specific gravity of .80 or greater. The visibility of the float is enhanced against the highly reflective Stainless Steel retainer. The retainer also acts as a baffle to dampen oil turbulence. The tempered glass lens will not discolor, assuring a clear view. The HLG-1050 liquid level gauge is suitable for 120°C application.

**SOLUTIONS** Heartland personnel have been assisting customers with transformer control and instrumentation applications since 1970. We invite you to contact our customer service professionals with your requirements. Heartland is the source for quality products, fast service and dependable support. The next time your application requires a liquid level gauge, order the HLG-1050 from the solutions company, Heartland Solutions.

The Heartland HLG family of liquid level gauge includes models for other level spans and mountings. For information on other members of the HLG liquid level gauge family or other fine Heartland products for electrical equipment, please phone, fax or E-mail Heartland Solutions.

 **Heartland Products Division**

**Heartland Solutions, Inc.**  
**630 Brooker Creek Blvd.**  
**Suite 345**  
**Oldsmar, FL 34677**

**Phone: 800.957.3493**  
**Fax: 877.779.4567**  
**Internet: info@hland.com**