

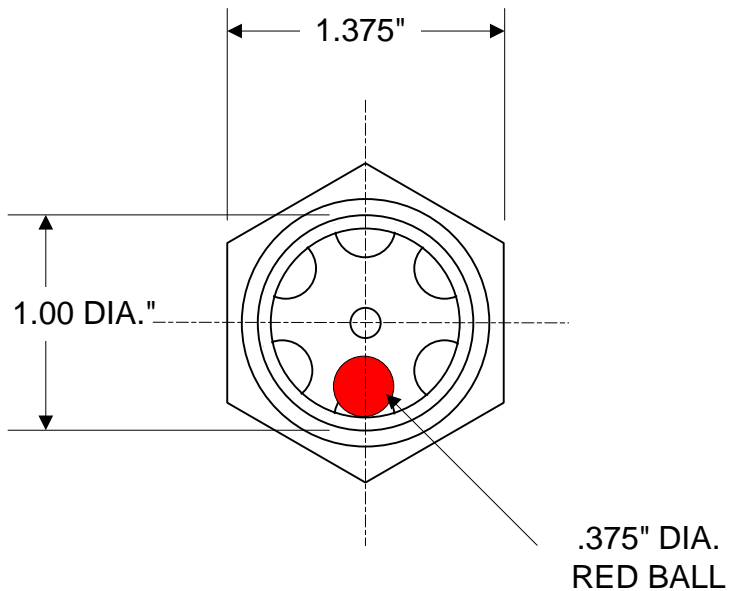

**Heartland**  
SOLUTIONS, INC.

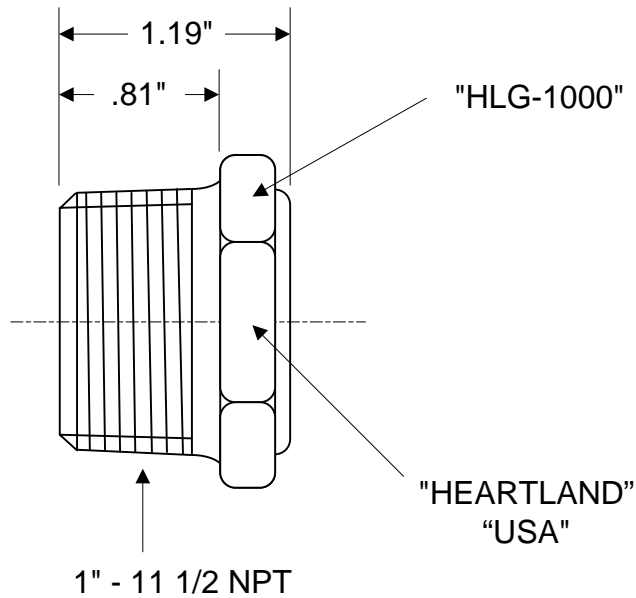

**Part Description**

**Body**

**Lens**

**Seals**

**Washer**

**Reflector**

**Float**

**Material**

**Brass**

**Soda Lime**

**Nitrile**

**Brass**

**Stainless Steel**

**Solid Red Polymer for use  
with Fluids of 0.83 or Greater  
Specific Gravity**

**Operation**

**Suitable for applications which operate  
up to 120 degrees C**

**Fluid Compatibility:**

**Mineral Oil**

**FR3 and Similar Ester Based Fluids**

HLG-1000-012 1" SIGHT GAUGE		REVISION 10
SCALE: NONE		REVISION DATE: 23 FEB 2004
HEARTLAND SOLUTIONS, INC.		DRAWING NO.
PH: 800.957.3493 FAX 877.779.4567		<b>HLG-1000-012</b>
info@hland.com	www.heartlandsolutionsinc.com	

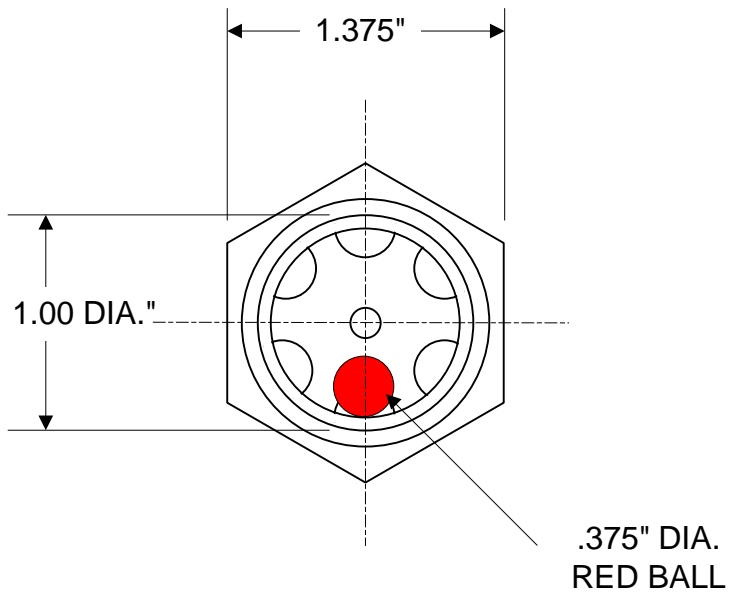
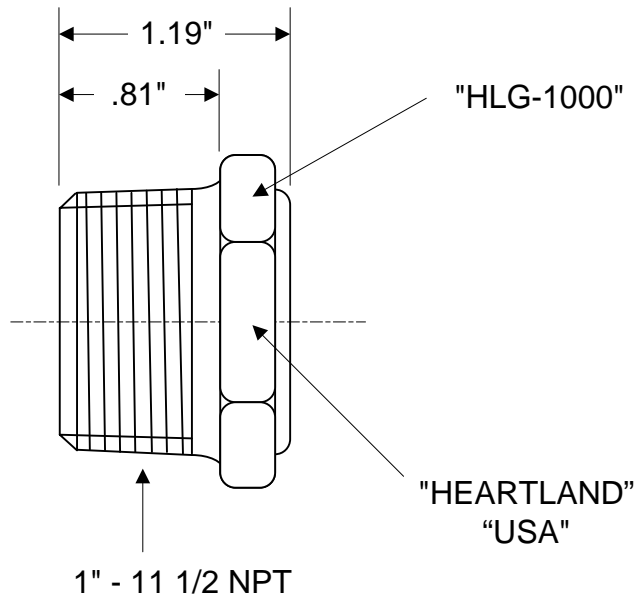

<u>Part Description</u>	<u>Material</u>
Body	Brass
Lens	Soda Lime
Seals	Nitrile
Washer	Brass
Reflector	Stainless Steel
Float	Solid Red Polymer for use with Fluids of 0.83 or Greater Specific Gravity
Sealant	Loctite® Vibra-Seal 516

**Operation**  
 Suitable for applications which operate up to 120 degrees C

**Fluid Compatibility:**  
 Mineral Oil  
 FR3 and Similar Ester Based Fluids

HLG-1000-R8 1" SIGHT GAUGE with VIBRA-SEAL		REVISION 08
SCALE: NONE		REVISION DATE: 23 FEB 2004
HEARTLAND SOLUTIONS, INC.		DRAWING NO.
PH: 800.957.3493 FAX 877.779.4567		<b>HLG-1000-R8</b>
info@hland.com	www.heartlandsolutionsinc.com	



**Heartland**  
SOLUTIONS, INC.

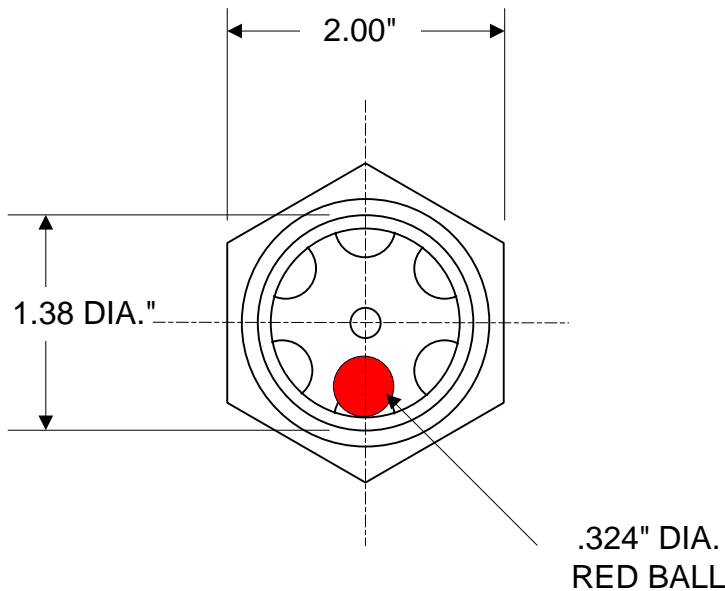
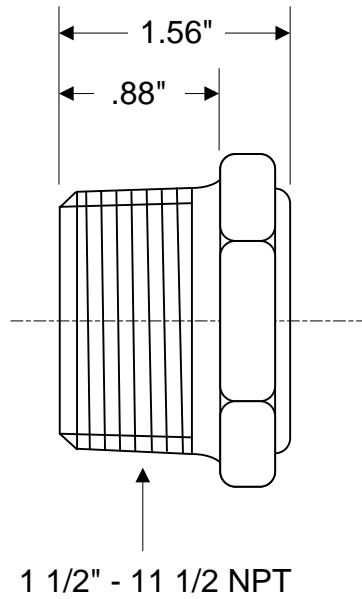

**Part Description**

**Body**

**Lens**

**Seals**

**Washer**

**Reflector**

**Float**

**Material**

**Brass**

**Soda Lime**

**Nitrile**

**Brass**

**Stainless Steel**

**Solid Red Polymer for use  
with Fluids of 0.83 or Greater  
Specific Gravity**

**Operation**

**Suitable for applications which operate  
up to 120 degrees C**

**Fluid Compatibility:**

**Mineral Oil**

**FR3 and Similar Ester Based Fluids**

HLG-1006 1 1/2" SIGHT GAUGE		REVISION 00
SCALE: NONE		REVISION DATE: 05 FEB 1999
HEARTLAND SOLUTIONS, INC.		DRAWING NO.
PH: 800.957.3493 FAX 877.779.4567		<b>HLG-1006</b>
info@hland.com	www.heartlandsolutionsinc.com	

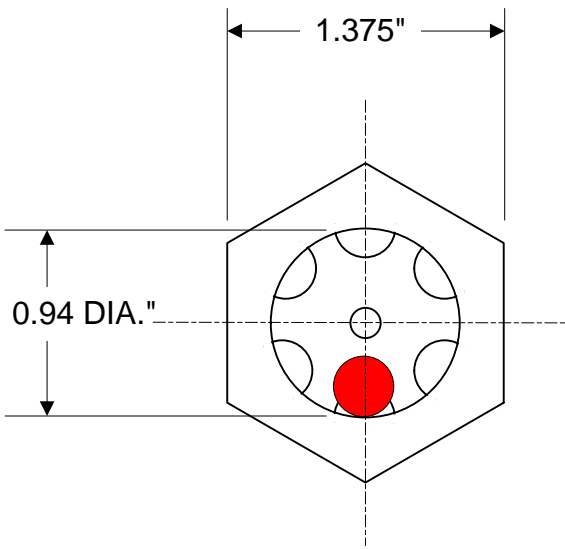
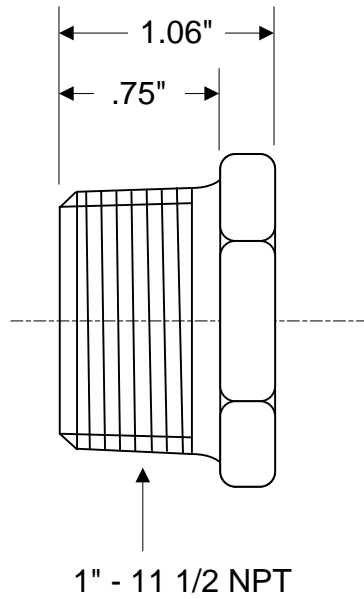

**Part Description**

Body

Lens

Reflector

Float

**Material**

Electroless Nickel Plated Steel

Glass Fused To Body

Stainless Steel

Solid Red Polymer for use with Fluids of 0.83 or Greater Specific Gravity

**Operation**

Suitable for applications which operate up to 120 degrees C

**Fluid Compatibility:**

Mineral Oil

FR3 and Similar Ester Based Fluids

HLG-1010 1" SIGHT GAUGE		REVISION 00
SCALE: NONE		REVISION DATE: 21 NOV 2007
HEARTLAND SOLUTIONS, INC.		DRAWING NO.
PH: 800.957.3493 FAX 877.779.4567		<b>HLG-1010</b>
info@hland.com	www.heartlandsolutionsinc.com	

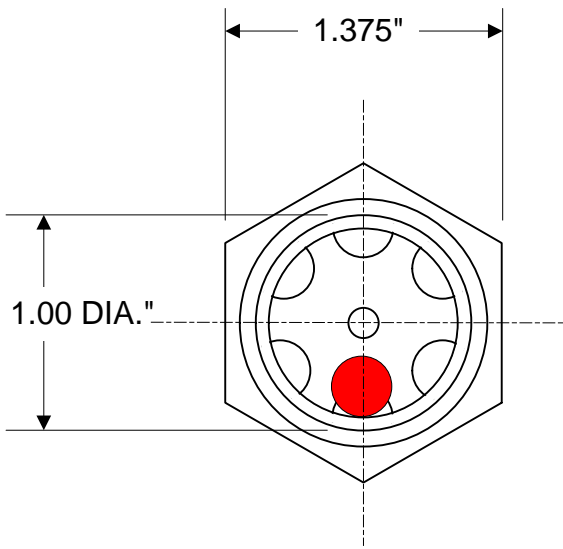
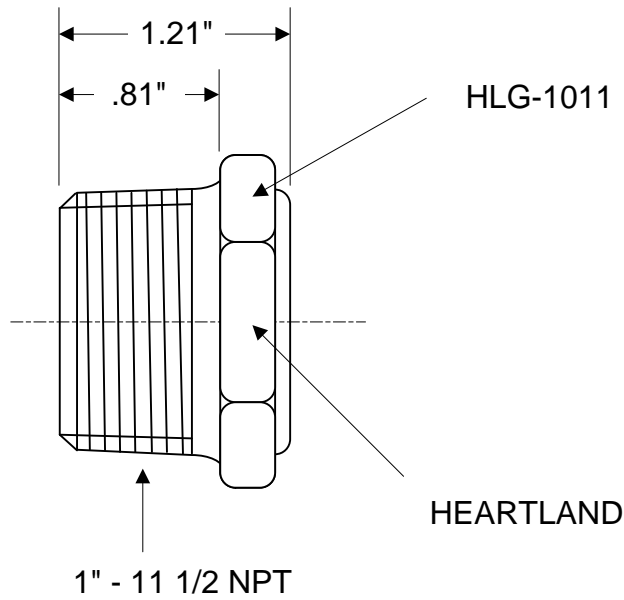

**Part Description**

**Body**

**Lens**

**Seals**

**Washer**

**Reflector**

**Float**

**Material**

**Brass**

**Fused Glass**

**Nitrile**

**Brass**

**Stainless Steel**

**Solid Red Polymer for use with Fluids of 0.83 or Greater Specific Gravity**

**Operation**

Suitable for applications which operate up to 120 degrees C

**Fluid Compatibility:**

**Mineral Oil**

**FR3 and Similar Ester Based Fluids**

HLG-1011 1" SIGHT GAUGE		REVISION 01
SCALE: NONE		REVISION DATE: 1 JUL 2011
HEARTLAND SOLUTIONS, INC.		DRAWING NO.
PH: 800.957.3493 FAX 877.779.4567		<b>HLG-1011</b>
info@hland.com	www.heartlandsolutionsinc.com	

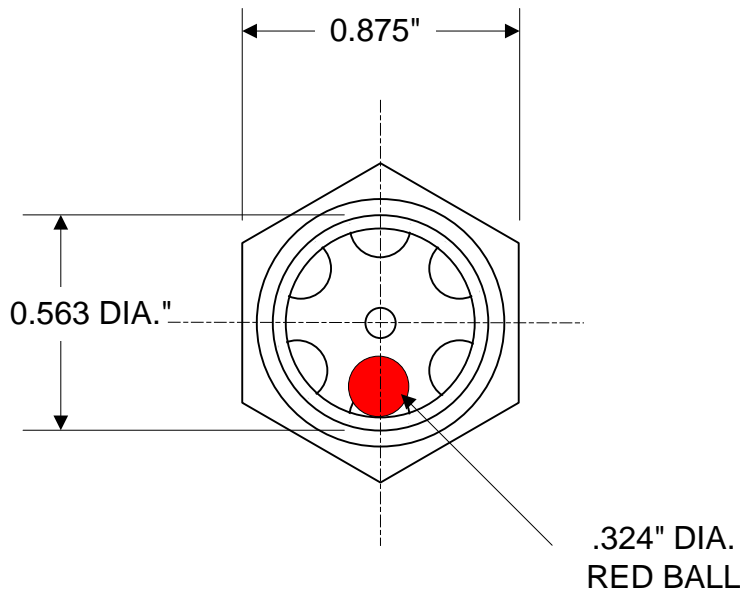
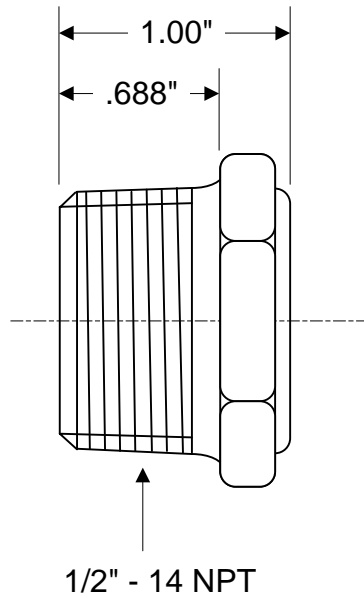

**Part Description**

**Body**

**Lens**

**Seals**

**Washer**

**Reflector**

**Float**

**Material**

**Brass**

**Soda Lime**

**Nitrile**

**Brass**

**Stainless Steel**

**Solid Red Polymer for use with Fluids of 0.83 or Greater Specific Gravity**

**Operation**

Suitable for applications which operate up to 120 degrees C

**Fluid Compatibility:**

**Mineral Oil**

**FR3 and Similar Ester Based Fluids**

HLG-1050 1/2" SIGHT GAUGE		REVISION 00
SCALE: NONE		REVISION DATE: 23 FEB 1999
HEARTLAND SOLUTIONS, INC.		DRAWING NO.
PH: 800.957.3493 FAX 877.779.4567		<b>HLG-1050</b>
info@hland.com	www.heartlandsolutionsinc.com	

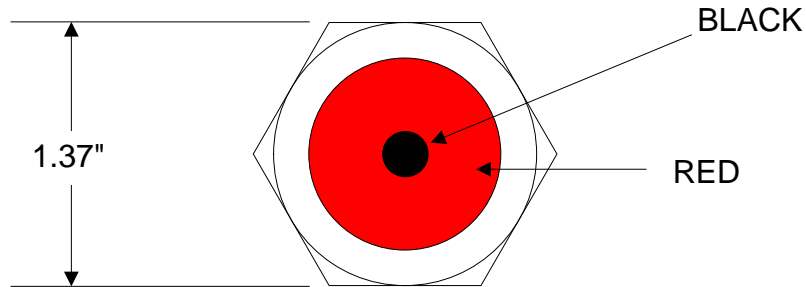

<u>Part Description</u>	<u>Material</u>
Body	Brass
Rod	Acrylic
Seals	Viton

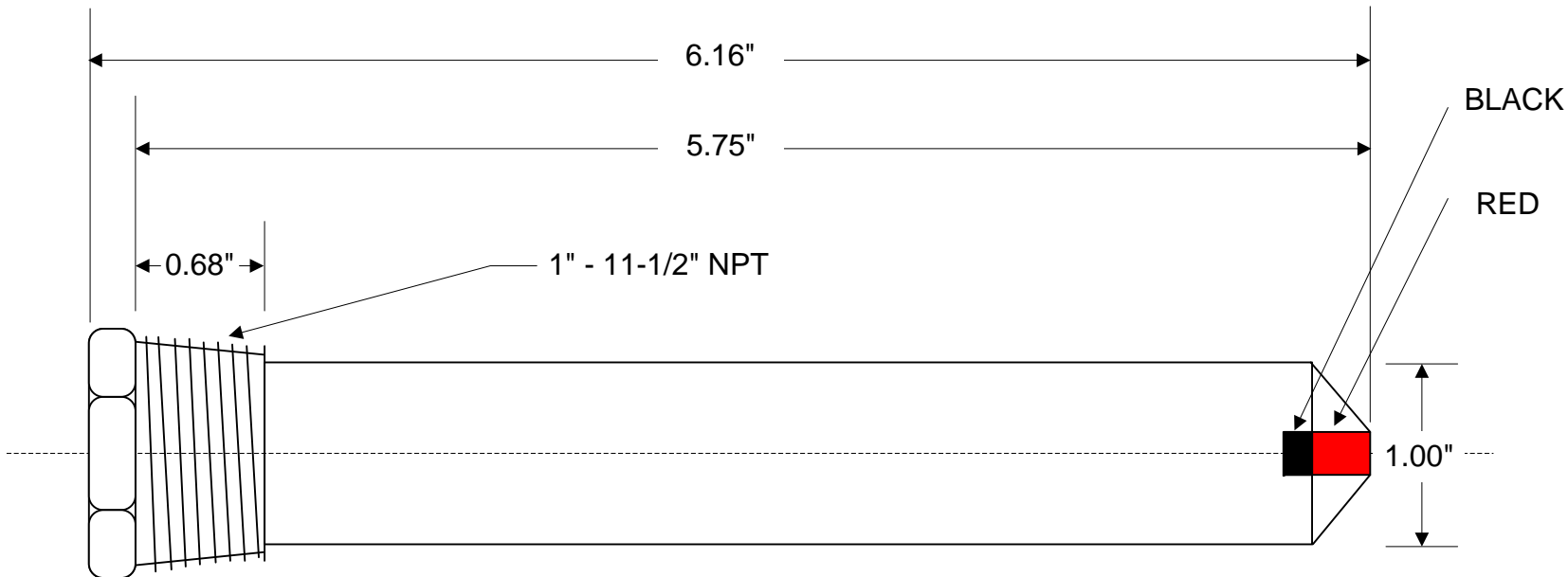

**Operation**

Suitable for applications which operate up to 120 degrees C

**Fluid Compatibility:**

Mineral Oil  
FR3 and Similar Ester Based Fluids

HLG-1055 1" LIQUID LEVEL GAUGE		REVISION 02
SCALE: NONE		REVISION DATE: 01 JUNE 2007
HEARTLAND SOLUTIONS, INC.		DRAWING NO.
PH: 800.957.3493 FAX 877.779.4567		<b>HLG-1055-A00</b>
info@hland.com	www.heartlandsolutionsinc.com	

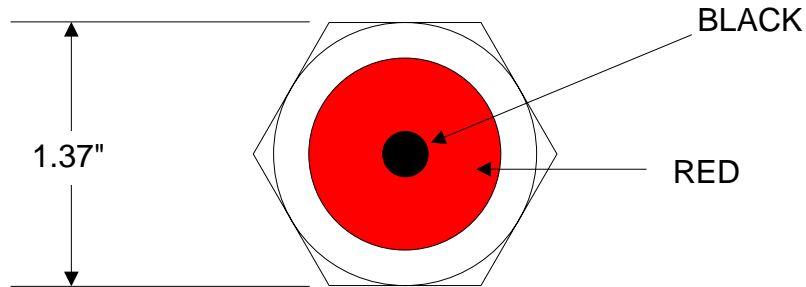

**Part Description**

Body  
Rod  
Seals  
Sealant

**Material**

Brass  
Acrylic  
Viton  
Loctite® Vibra-Seal 516

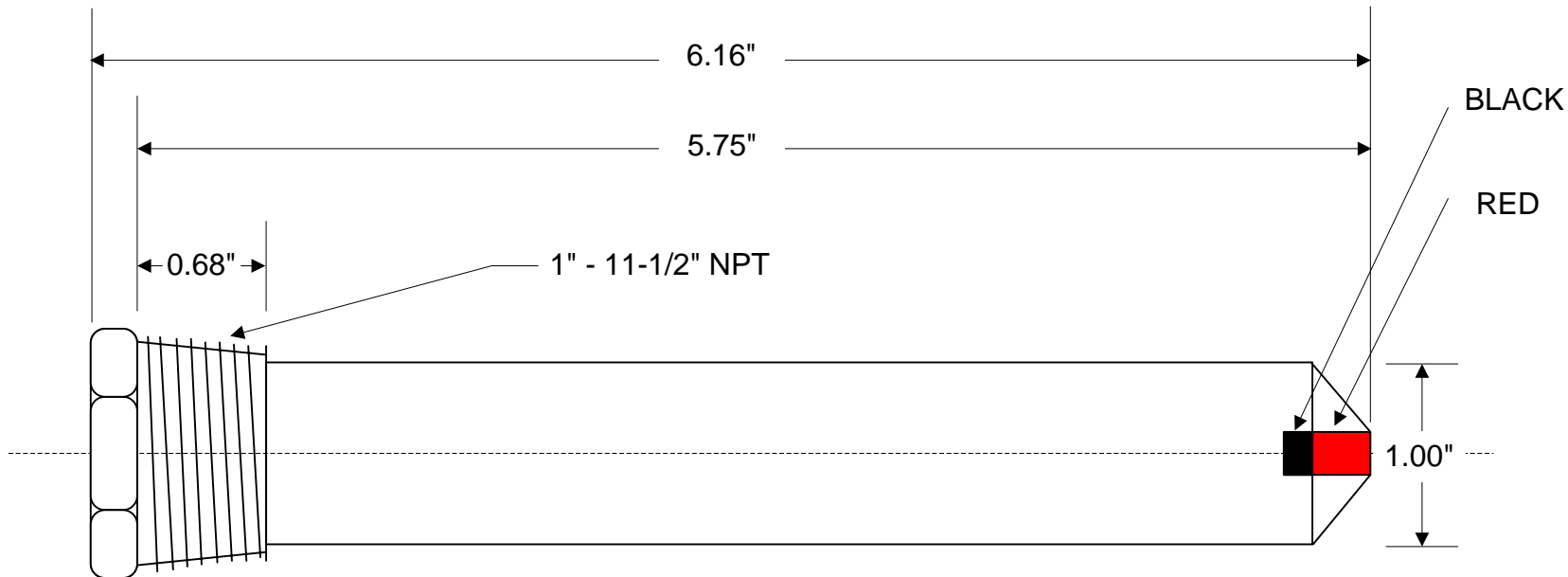

**Operation**

Suitable for applications which operate up to 120 degrees C

**Fluid Compatibility:**

Mineral Oil  
FR3 and Similar Ester Based Fluids

HLG-1055-100 1" LIQUID LEVEL GAUGE with VIBRA-SEAL		REVISION 00
SCALE: NONE		REVISION DATE: 25 SEP 2009
HEARTLAND SOLUTIONS, INC.		DRAWING NO.
PH: 800.957.3493 FAX 877.779.4567		<b>HLG-1055-100</b>
info@hland.com	www.heartlandsolutionsinc.com	



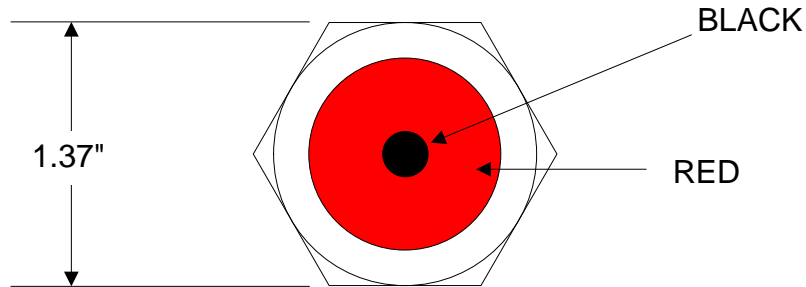

<u>Part Description</u>	<u>Material</u>
Body	Brass
Rod	Acrylic
Seals	Viton

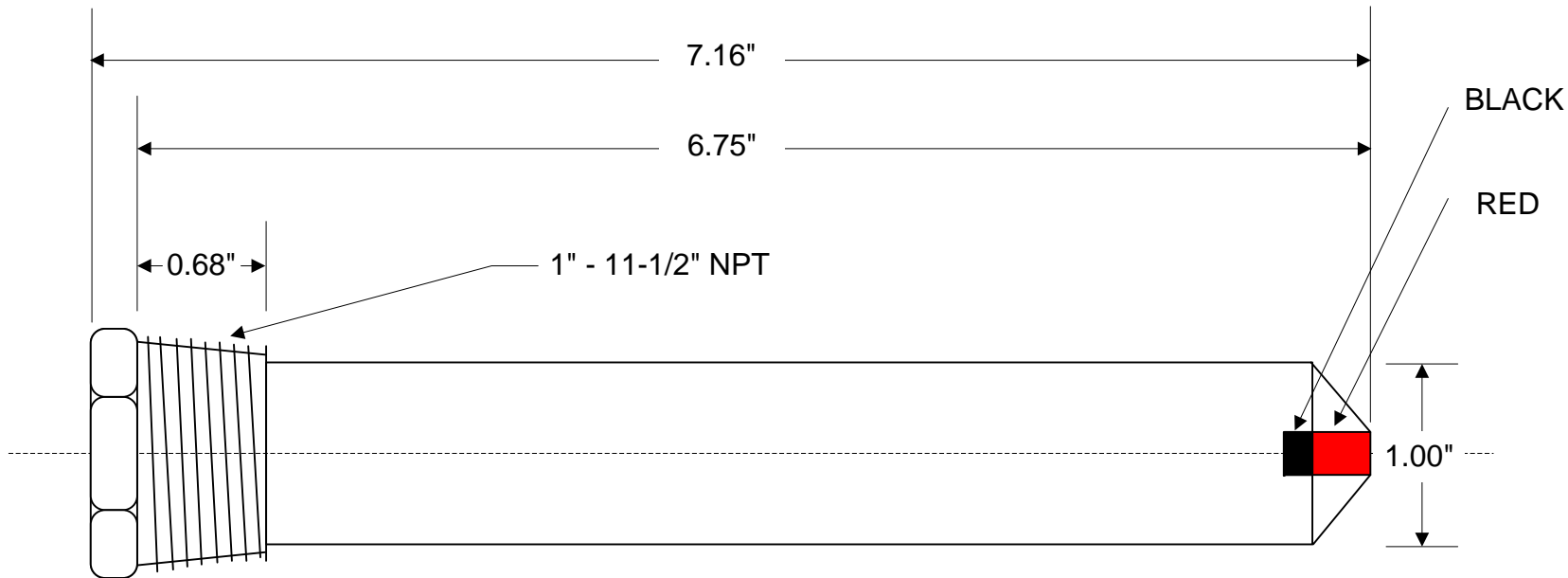

**Operation**

Suitable for applications which operate up to 120 degrees C

**Fluid Compatibility:**

Mineral Oil  
FR3 and Similar Ester Based Fluids

HLG-1065 1" LIQUID LEVEL GAUGE		REVISION 03
SCALE: NONE		REVISION DATE: 01 JUNE 2007
HEARTLAND SOLUTIONS, INC.		DRAWING NO.
PH: 800.957.3493 FAX 877.779.4567		<b>HLG-1065-A00</b>
info@hland.com	www.heartlandsolutionsinc.com	

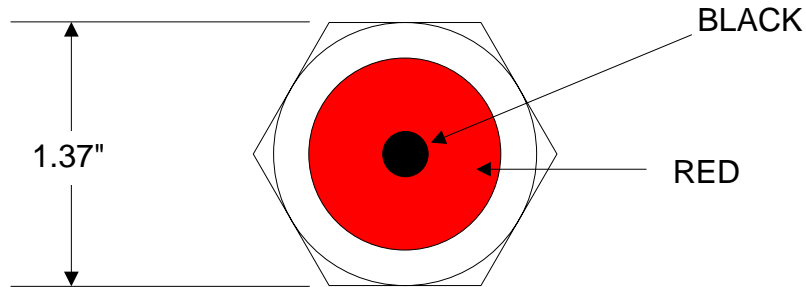

**Part Description**

Body  
Rod  
Seals  
Sealant

**Material**

Brass  
Acrylic  
Viton  
Loctite® Vibra-Seal 516

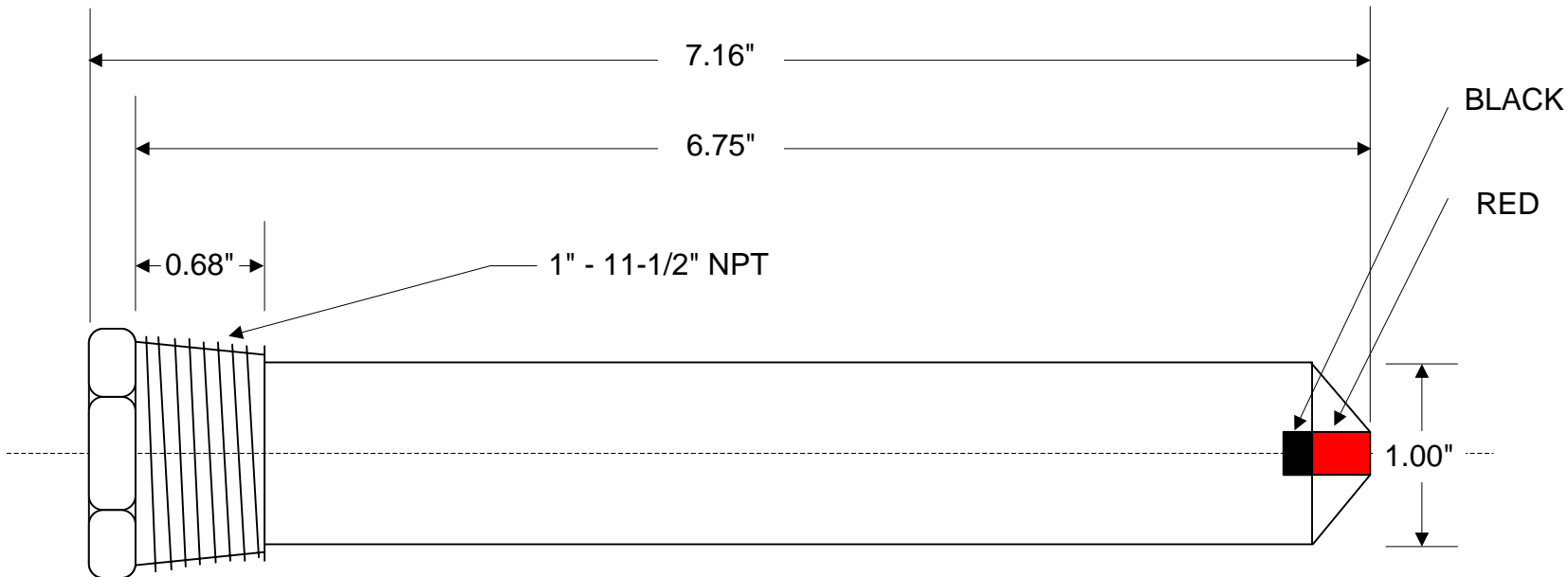

**Operation**

Suitable for applications which operate up to 120 degrees C

**Fluid Compatibility:**

Mineral Oil  
FR3 and Similar Ester Based Fluids

HLG-1065-100 1" LIQUID LEVEL GAUGE with VIBRA-SEAL		REVISION 02
SCALE: NONE		REVISION DATE: 01 JUNE 2007
HEARTLAND SOLUTIONS, INC.		DRAWING NO.
PH: 800.957.3493 FAX 877.779.4567		<b>HLG-1065-100</b>
info@hland.com	www.heartlandsolutionsinc.com	

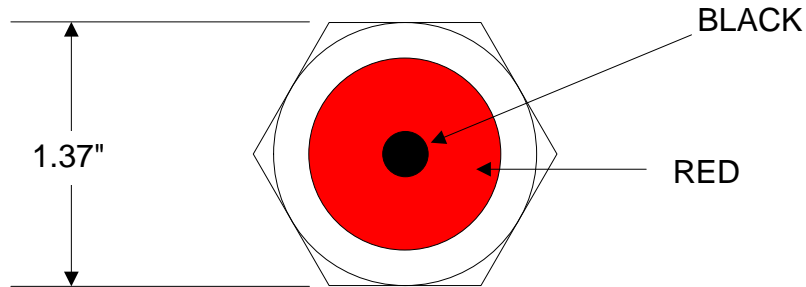

**Part Description**

Body  
Rod  
Seals  
Thread Sealant

**Material**

316L Stainless Steel  
Acrylic  
Viton  
Loctite® Vibra-Seal 516

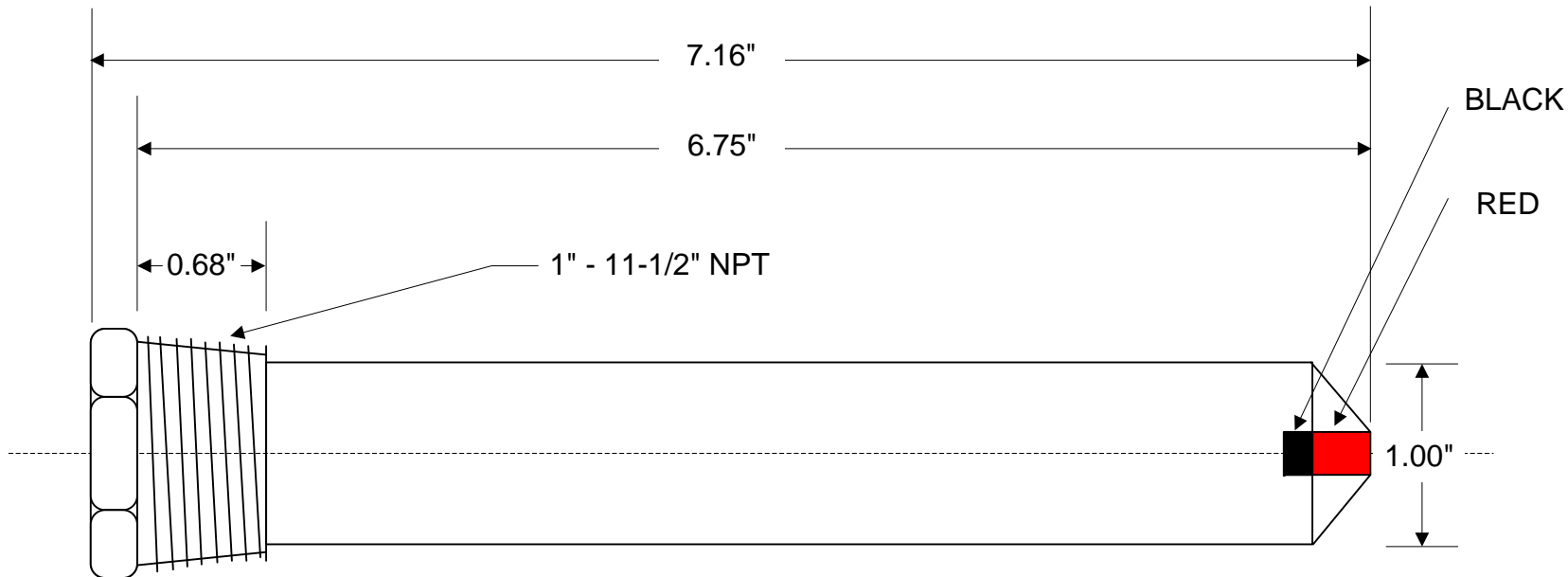

**Operation**

Suitable for applications which operate up to 120 degrees C

**Fluid Compatibility:**

Mineral Oil  
FR3 and Similar Ester Based Fluids

1" LIQUID LEVEL GAUGE w/STAINLESS STEEL BODY		REVISION 00
SCALE: NONE		REVISION DATE: 11 MAR 2015
HEARTLAND SOLUTIONS, INC.		DRAWING NO.
PH: 813.386.1644 FAX 813.386.1648		<b>HLG-1065-316</b>
info@hland.com	www.heartlandsolutionsinc.com	

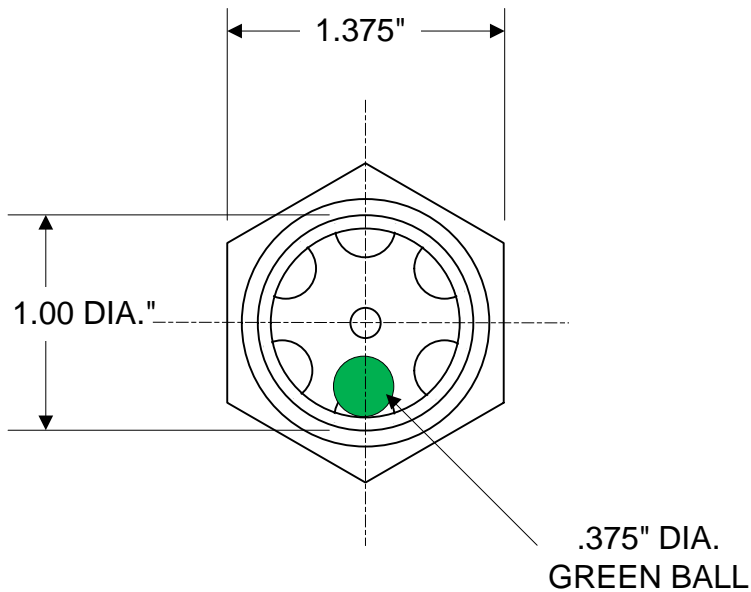
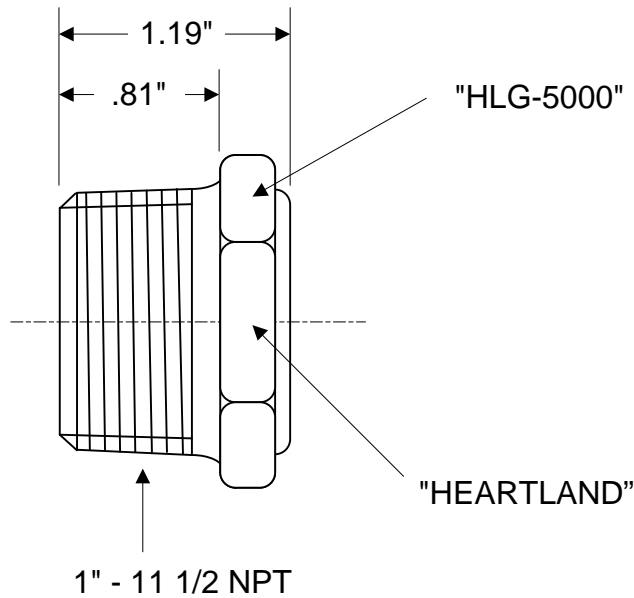

**Part Description**

**Body**

**Lens**

**Seals**

**Washer**

**Reflector**

**Float**

**Sealant**

**Material**

**Brass**

**Soda Lime**

**Nitrile**

**Brass**

**Stainless Steel**

**Green Polymer for use with Fluids of 0.45 or Greater Specific Gravity**

**Loctite® Vibra-Seal 516**

**Operation**

**Suitable for applications which operate up to 120 degrees C**

**Fluid Compatibility:**

**Luminol or Similar Specific Gravity Based Fluids**

HLG-5000 1" SIGHT GAUGE w/VIBRA SEAL		REVISION 00
SCALE: NONE		REVISION DATE: 12 JUN 2014
HEARTLAND SOLUTIONS, INC.		DRAWING NO.
PH: 800.957.3493 FAX 877.779.4567		<b>HLG-5000-VIB</b>
info@hland.com	www.heartlandsolutionsinc.com	